

Matrix Stiffness Method
4th Year
Structural Engineering

2009/10

Dr. Colin Caprani

Contents

1. Introduction	4
1.1 Background.....	4
1.2 Basic Concepts.....	5
1.3 Basic Approach.....	7
1.4 Example 1	11
1.5 General Methodology	16
1.6 Member contribution to global stiffness matrix	17
1.7 Interpretation of Stiffness Matrix	20
1.8 Restricting a Matrix	22
2. Plane Trusses	24
2.1 Introduction.....	24
2.2 Truss Element Stiffness Matrix	25
2.3 Element Forces	28
2.4 Example 2: Basic Truss	30
2.5 Example 3: Adding Members.....	38
2.6 Example 4: Using Symmetry.....	41
2.7 Self-Strained Structures	44
2.8 Example 5 – Truss with Differential Temperature.....	48
2.9 Example 6 – Truss with Loads & Self Strains	54
2.10 Problems.....	59
3. Beams.....	61
3.1 Beam Element Stiffness Matrix.....	61
3.2 Beam Element Loading	66
3.3 Example 7 – Simple Two-Span Beam.....	68
3.4 Example 8 – Non-Prismatic Beam	72
3.5 Problems	76
4. Plane Frames.....	78

4.1	Plane Frame Element Stiffness Matrix.....	78
4.2	Example 9 – Simple Plane Frame	87
4.3	Example 10 –Plane Frame Using Symmetry	92
4.4	Problems	98
5.	Appendix	100
5.1	Plane Truss Element Stiffness Matrix in Global Coordinates.....	100
5.2	Coordinate Transformations	109
5.3	Past Exam Questions	117

1. Introduction

1.1 Background

The matrix stiffness method is the basis of almost all commercial structural analysis programs. It is a specific case of the more general finite element method, and was in part responsible for the development of the finite element method. An understanding of the underlying theory, limitations and means of application of the method is therefore essential so that the user of analysis software is not just operating a ‘black box’. Such users must be able to understand any errors in the modelling of structures which usually come as obtuse warnings such as ‘zero pivot’ or ‘determinant zero: structure unstable: aborting’. Understanding the basics presented herein should hopefully lead to more fruitful use of the available software.

Note: LinPro is very useful as a study aid for this topic: right click on a member and select “Stiffness Matrix” to see the stiffness matrix for any member.

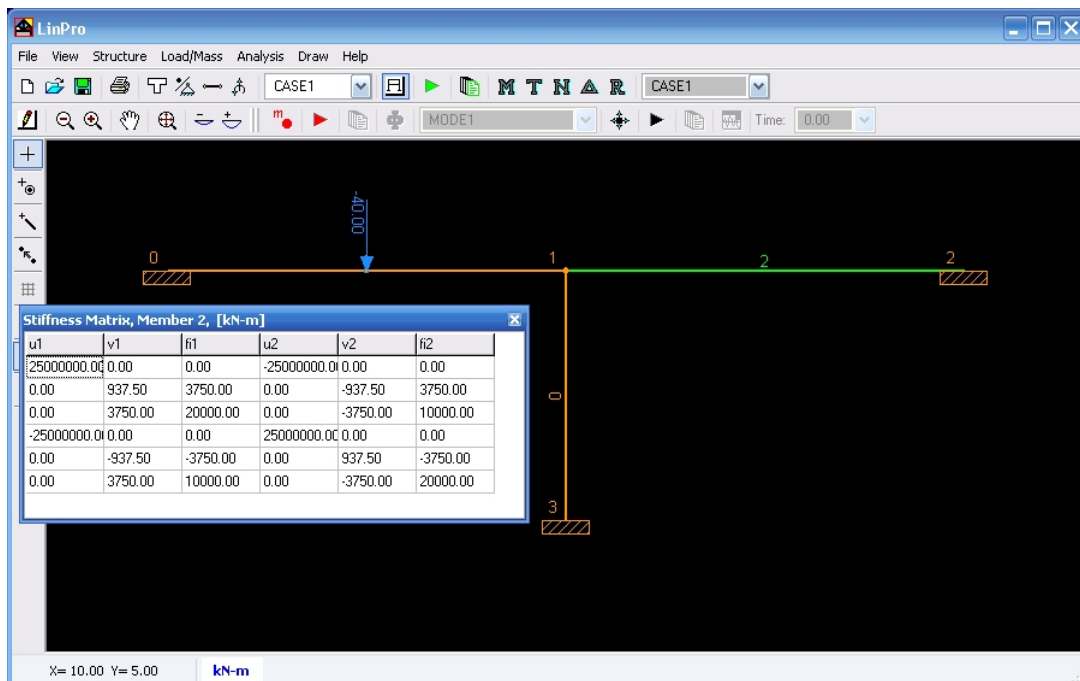

1.2 *Basic Concepts*

Node

The more general name for a connection between adjacent members is termed a node. For trusses and frames the terms joint and node are interchangeable. For more complex structures (e.g. plates), they are not.

Element

For trusses and frames element means the same as member. For more complex structures this is not the case.

Degree of Freedom

The number of possible directions that displacements or forces at a node can exist in is termed a degree of freedom (dof). Some examples are:

- Plane truss: has 2 degrees of freedom at each node: translation/forces in the x and y directions.
- Beams: have 2 degrees of freedom per node: vertical displacement/forces and rotation/moment.
- Plane Frame: has 3 degrees of freedom at each node: the translations/forces similar to a plane truss and in addition, the rotation or moment at the joint.
- Space Truss: a truss in three dimensions has 3 degrees of freedom: translation or forces along each axis in space.
- Space Frame: has 6 degrees of freedom at each node: translation/forces along each axis, and rotation/moments about each axis.

Thus a plane truss with 10 joints has 20 degrees of freedom. A plane frame with two members will have three joints (one common to both members) and thus 9 degrees of freedom in total.

Local and Global

Forces, displacements and stiffness matrices are often derived and defined for an axis system local to the member. However there will exist an overall, or global, axis system for the structure as a whole. We must therefore transform forces, displacements etc from the local coordinate system into the global coordinate system.

1.3 Basic Approach

Individual Element

We consider here the most basic form of stiffness analysis. We represent a structural member by a spring which has a node (or connection) at each end. We also consider that it can only move in the x -direction. Thus it only has 1 DOF per node. At each of its nodes, it can have a force and a displacement (again both in the x -direction):

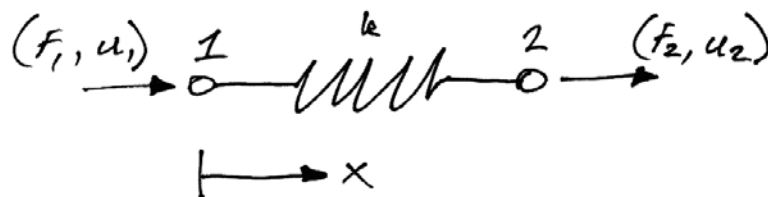

Notice that we have drawn the force and displacement vector arrows in the positive x -direction. Matrix analysis requires us to be very strict in our sign conventions.

Using the basic relationship that force is equal to stiffness times displacement, we can determine the force at node 1 as:

$$F_1 = k(\text{net displacement at 1})$$

Thus:

$$F_1 = k(u_1 - u_2) = ku_1 - ku_2 \quad (1.1)$$

Similarly for node 2:

$$F_2 = k(u_2 - u_1) = -ku_1 + ku_2 \quad (1.2)$$

We can write equations (1.1) and (1.2) in matrix form:

$$\begin{Bmatrix} F_1 \\ F_2 \end{Bmatrix} = \begin{bmatrix} k & -k \\ -k & k \end{bmatrix} \begin{Bmatrix} u_1 \\ u_2 \end{Bmatrix} \quad (1.3)$$

And using matrix notation, we write:

$$\{\mathbf{F}^e\} = [\mathbf{k}]\{\mathbf{u}^e\} \quad (1.4)$$

Here:

- $\{\mathbf{F}^e\}$ is the element force vector;
- $[\mathbf{k}]$ is the element stiffness matrix;
- $\{\mathbf{u}^e\}$ is the element displacement vector.

It should be clear that the element stiffness matrix is of crucial importance – it links nodal forces to nodal displacements; it encapsulates how the element behaves under load.

The derivation of the element stiffness matrix for different types of elements is probably the most awkward part of the matrix stiffness method. However, this does not pose as a major disadvantage since we only have a few types of elements to derive, and once derived they are readily available for use in any problem.

Assemblies of Elements

Real structures are made up of assemblies of elements, thus we must determine how to connect the stiffness matrices of individual elements to form an overall (or global) stiffness matrix for the structure.

Consider the following simple structure:

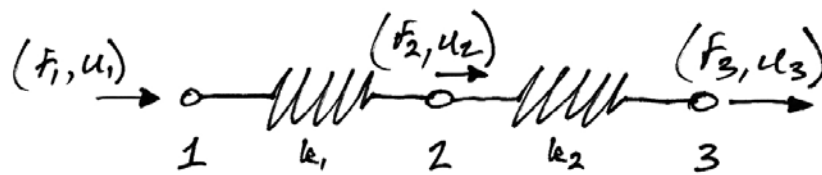

Note that the individual elements have different stiffnesses, k_1 and k_2 . Thus we can write the force displacement relationships for both elements as:

$$\begin{Bmatrix} F_1 \\ F_2 \end{Bmatrix} = \begin{bmatrix} k_1 & -k_1 \\ -k_1 & k_1 \end{bmatrix} \begin{Bmatrix} u_1 \\ u_2 \end{Bmatrix} \quad (1.5)$$

$$\begin{Bmatrix} F_2 \\ F_3 \end{Bmatrix} = \begin{bmatrix} k_2 & -k_2 \\ -k_2 & k_2 \end{bmatrix} \begin{Bmatrix} u_2 \\ u_3 \end{Bmatrix} \quad (1.6)$$

We can expand these equations so that they encompass all the nodes in the structure:

$$\begin{Bmatrix} F_1 \\ F_2 \\ F_3 \end{Bmatrix} = \begin{bmatrix} k_1 & -k_1 & 0 \\ -k_1 & k_1 & 0 \\ 0 & 0 & 0 \end{bmatrix} \begin{Bmatrix} u_1 \\ u_2 \\ u_3 \end{Bmatrix} \quad (1.7)$$

$$\begin{Bmatrix} F_1 \\ F_2 \\ F_3 \end{Bmatrix} = \begin{bmatrix} 0 & 0 & 0 \\ 0 & k_2 & -k_2 \\ 0 & -k_2 & k_2 \end{bmatrix} \begin{Bmatrix} u_1 \\ u_2 \\ u_3 \end{Bmatrix} \quad (1.8)$$

We can add equations (1.7) and (1.8) to determine the total of both the forces and displacements at each node in the structure:

$$\begin{Bmatrix} F_1 \\ F_2 \\ F_3 \end{Bmatrix} = \begin{bmatrix} k_1 & -k_1 & 0 \\ -k_1 & k_1 + k_2 & -k_2 \\ 0 & -k_2 & k_2 \end{bmatrix} \begin{Bmatrix} u_1 \\ u_2 \\ u_3 \end{Bmatrix} \quad (1.9)$$

As can be seen from this equation, by adding, we have the total stiffness at each node, with contributions as appropriate by each member. In particular node 2, where the members meet, has total stiffness $k_1 + k_2$. We can re-write this equation as:

$$\{\mathbf{F}\} = [\mathbf{K}]\{\mathbf{u}\} \quad (1.10)$$

In which:

- $\{\mathbf{F}\}$ is the force vector for the structure;
- $[\mathbf{K}]$ is the global stiffness matrix for the structure;
- $\{\mathbf{u}\}$ is the displacement vector for the structure.

1.4 Example 1

Problem

The following axially-loaded structure has loads applied as shown:

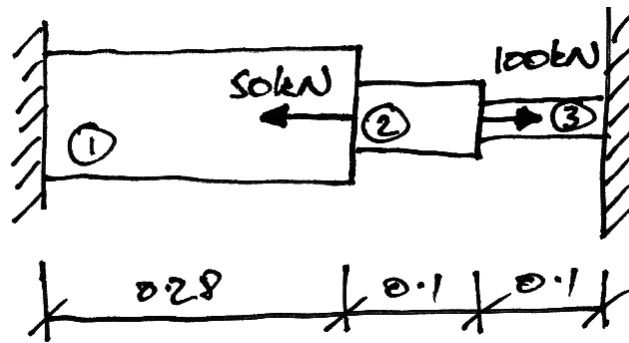

The individual member properties are:

Member	Length (m)	Area (mm ²)	Material, E (kN/mm ²)
1	0.28	400	70
2	0.1	200	100
3	0.1	70	200

Find the displacements of the connections and the forces in each member.

Solution

Our first step is to model the structure with elements and nodes, as shown:

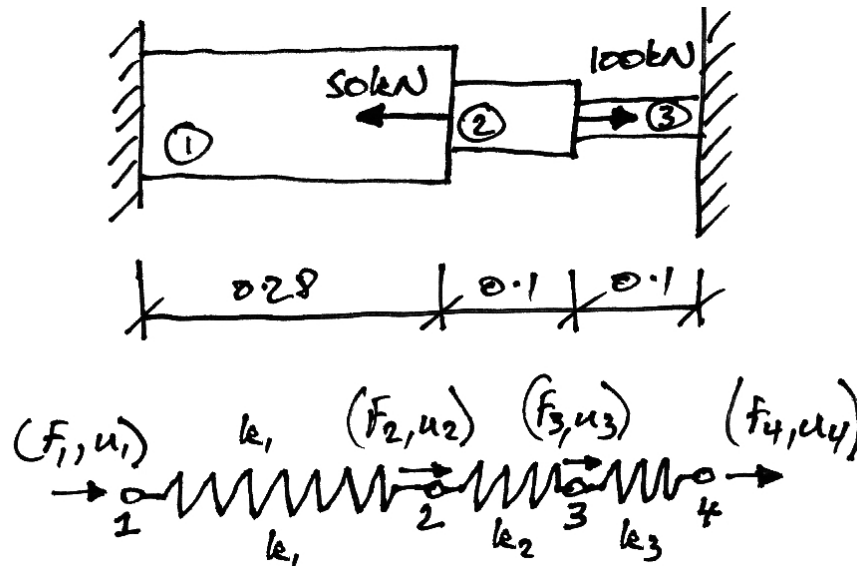

Calculate the spring stiffnesses for each member:

$$k_1 = \left(\frac{EA}{L} \right)_1 = \frac{70 \cdot 400}{0.28} = 100 \times 10^3 \text{ kN/m} \quad (1.11)$$

$$k_2 = \left(\frac{EA}{L} \right)_2 = \frac{100 \cdot 200}{0.1} = 200 \times 10^3 \text{ kN/m} \quad (1.12)$$

$$k_3 = \left(\frac{EA}{L} \right)_3 = \frac{200 \cdot 70}{0.1} = 140 \times 10^3 \text{ kN/m} \quad (1.13)$$

Next we calculate the individual element stiffness matrices:

$$\begin{Bmatrix} F_1 \\ F_2 \end{Bmatrix} = 10^3 \begin{bmatrix} 100 & -100 \\ -100 & 100 \end{bmatrix} \begin{Bmatrix} u_1 \\ u_2 \end{Bmatrix} \quad (1.14)$$

$$\begin{Bmatrix} F_2 \\ F_3 \end{Bmatrix} = 10^3 \begin{bmatrix} 200 & -200 \\ -200 & 200 \end{bmatrix} \begin{Bmatrix} u_2 \\ u_3 \end{Bmatrix} \quad (1.15)$$

$$\begin{Bmatrix} F_3 \\ F_4 \end{Bmatrix} = 10^3 \begin{bmatrix} 140 & -140 \\ -140 & 140 \end{bmatrix} \begin{Bmatrix} u_3 \\ u_4 \end{Bmatrix} \quad (1.16)$$

We expand and add the element stiffness matrices to get:

$$\begin{Bmatrix} F_1 \\ F_2 \\ F_3 \\ F_4 \end{Bmatrix} = 10^3 \begin{bmatrix} 100 & -100 & 0 & 0 \\ -100 & (100+200) & -200 & 0 \\ 0 & -200 & (200+140) & -140 \\ 0 & 0 & -140 & 140 \end{bmatrix} \begin{Bmatrix} u_1 \\ u_2 \\ u_3 \\ u_4 \end{Bmatrix} \quad (1.17)$$

Notice how each member contributes to the global stiffness matrix:

	Node 1	Node 2	Node 3	Node 4
Node 1	Member 1		0	0
Node 2			Member 2	
Node 3	0	Member 3		
Node 4	0			0

Notice also that where the member stiffness matrices overlap in the global stiffness matrix that the components (or entries) are added. Also notice that zeros are entered where there is no connection between nodes, e.g. node 1 to node 3.

We cannot yet solve equation (1.17) as we have not introduced the restraints of the structure: the supports at nodes 1 and 4. We must modify equation (1.17) in such a way that we will obtain the known results for the displacements at nodes 1 and 4. Thus:

$$\begin{Bmatrix} 0 \\ F_2 \\ F_3 \\ 0 \end{Bmatrix} = 10^3 \begin{bmatrix} 1 & 0 & 0 & 0 \\ 0 & (100+200) & -200 & 0 \\ 0 & -200 & (200+140) & 0 \\ 0 & 0 & 0 & 1 \end{bmatrix} \begin{Bmatrix} u_1 \\ u_2 \\ u_3 \\ u_4 \end{Bmatrix} \quad (1.18)$$

What we have done here is to ‘restrict’ the matrix: we have introduced a 1 on the diagonal of the node number, and set all other entries on the corresponding row and column to zero. We have entered the known displacement as the corresponding entry in force vector (zero). Thus when we now solve we will obtain $u_1 = u_4 = 0$.

For the remaining two equations, we have:

$$\begin{Bmatrix} F_2 \\ F_3 \end{Bmatrix} = 10^3 \begin{bmatrix} 300 & -200 \\ -200 & 340 \end{bmatrix} \begin{Bmatrix} u_2 \\ u_3 \end{Bmatrix} \quad (1.19)$$

And so:

$$\begin{Bmatrix} u_2 \\ u_3 \end{Bmatrix} = \frac{1}{10^3} \cdot \frac{1}{(300)(340) - (-200)(-200)} \begin{bmatrix} 340 & 200 \\ 200 & 300 \end{bmatrix} \begin{Bmatrix} -50 \\ 100 \end{Bmatrix} = \frac{1}{62} \begin{Bmatrix} 3 \\ 20 \end{Bmatrix} \times 10^{-3} \text{ m} \quad (1.20)$$

$$= \begin{Bmatrix} 0.048 \\ 0.322 \end{Bmatrix} \text{ mm}$$

To find the forces in the bars, we can now use the member stiffness matrices, since we know the end displacements:

Member 1

$$\begin{Bmatrix} F_1 \\ F_2 \end{Bmatrix} = 10^3 \begin{bmatrix} 100 & -100 \\ -100 & 100 \end{bmatrix} \begin{Bmatrix} 0 \\ 0.048 \end{Bmatrix} \times 10^{-3} = \begin{Bmatrix} -4.8 \\ 4.8 \end{Bmatrix} \quad (1.21)$$

Thus Member 1 has a tension of 4.8 kN, since the directions of the member forces are interpreted by our sign convention:



Also note that it is in equilibrium (as we might expect).

Member 2

$$\begin{Bmatrix} F_2 \\ F_3 \end{Bmatrix} = 10^3 \begin{bmatrix} 200 & -200 \\ -200 & 200 \end{bmatrix} \begin{Bmatrix} 0.048 \\ 0.322 \end{Bmatrix} \times 10^{-3} = \begin{Bmatrix} -54.8 \\ 54.8 \end{Bmatrix} \quad (1.22)$$

Member 2 thus has tension of 54.8 kN.

Member 3

$$\begin{Bmatrix} F_3 \\ F_4 \end{Bmatrix} = 10^3 \begin{bmatrix} 140 & -140 \\ -140 & 140 \end{bmatrix} \begin{Bmatrix} 0.322 \\ 0 \end{Bmatrix} \times 10^{-3} = \begin{Bmatrix} 45.08 \\ -45.08 \end{Bmatrix} \quad (1.23)$$

Thus Member 3 has a compression of 45.08 kN applied to it.

1.5 General Methodology

The general steps in Matrix Stiffness Method are:

1. Calculate the member stiffness matrices
2. Assemble the global stiffness matrix
3. Restrict the global stiffness matrix and force vector
4. Solve for the unknown displacements
5. Determine member forces from the known displacements and member stiffness matrices
6. Determine the reactions knowing member end forces.

1.6 Member contribution to global stiffness matrix

Consider a member, ij , which links node i to node j . Its member stiffness matrix will be:

	Node i	Node j
Node i	$k_{11_{ij}}$	$k_{12_{ij}}$
Node j	$k_{21_{ij}}$	$k_{22_{ij}}$

Its entries must then contribute to the corresponding entries in the global stiffness matrix:

		Node i		Node j	
...
Node i	...	$k_{11_{ij}}$...	$k_{12_{ij}}$...
...
Node j	...	$k_{21_{ij}}$...	$k_{22_{ij}}$...
...

If we now consider another member, jl , which links node j to node l . Its member stiffness matrix will be:

	Node i	Node l
Node j	$k_{11_{jl}}$	$k_{12_{jl}}$
Node l	$k_{21_{jl}}$	$k_{22_{jl}}$

And now the global stiffness matrix becomes:

...	...	Node i	...	Node j	...	Node l	...
...
Node i	...	$k_{11_{ij}}$...	$k_{12_{ij}}$
...
Node j	...	$k_{21_{ij}}$...	$k_{22_{ij}} + k_{11_{jl}}$...	$k_{22_{jl}}$...
...
Node l	$k_{22_{jl}}$...	$k_{22_{jl}}$...
...

In the above, the identifiers k_{II} etc are sub-matrices of dimension:

$$ndof \times ndof$$

where $ndof$ refers to the number of degrees of freedom that each node has.

1.7 Interpretation of Stiffness Matrix

It is useful to understand what each term in a stiffness matrix represents. If we consider a simple example structure:

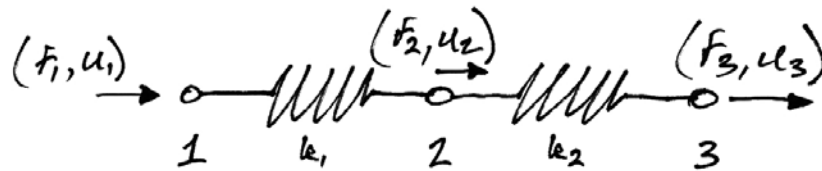

We saw that the global stiffness matrix for this is:

$$\mathbf{K} = \begin{bmatrix} K_{11} & K_{21} & K_{13} \\ K_{21} & K_{22} & K_{23} \\ K_{31} & K_{32} & K_{33} \end{bmatrix} = \begin{bmatrix} k_1 & -k_1 & 0 \\ -k_1 & k_1 + k_2 & -k_2 \\ 0 & -k_2 & k_2 \end{bmatrix}$$

If we imagine that all nodes are fixed against displacement except for node 2, then we have the following:

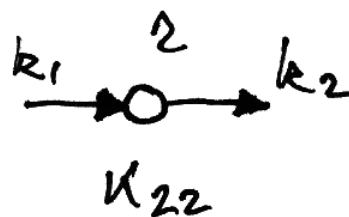
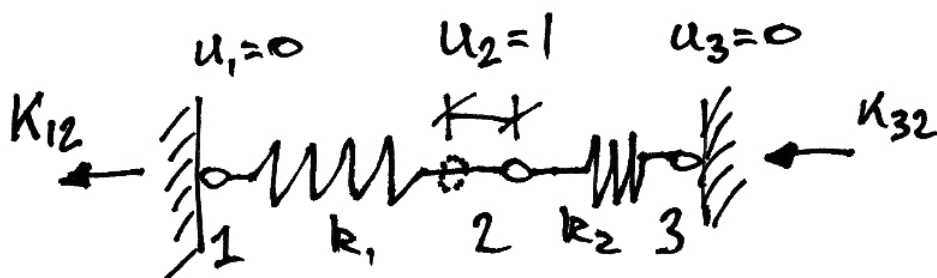

From our general equation:

$$\begin{Bmatrix} F_1 \\ F_2 \\ F_3 \end{Bmatrix} = \begin{bmatrix} K_{11} & K_{21} & K_{13} \\ K_{21} & K_{22} & K_{23} \\ K_{31} & K_{32} & K_{33} \end{bmatrix} \begin{Bmatrix} 0 \\ 1 \\ 0 \end{Bmatrix} = \begin{Bmatrix} K_{12} \\ K_{22} \\ K_{32} \end{Bmatrix} \quad (1.24)$$

Thus:

$$\begin{Bmatrix} F_1 \\ F_2 \\ F_3 \end{Bmatrix} = \begin{Bmatrix} K_{12} \\ K_{22} \\ K_{32} \end{Bmatrix} = \begin{Bmatrix} -k_1 \\ k_1 + k_2 \\ -k_2 \end{Bmatrix} \quad (1.25)$$

These forces are illustrated in the above diagram, along with a free-body diagram of node 2.

Thus we see that each column in a stiffness matrix represents the forces required to maintain equilibrium when the column's DOF has been given a unit displacement.

This provides a very useful way to derive member stiffness matrices.

1.8 Restricting a Matrix

In Example 1 we solved the structure by applying the known supports into the global stiffness matrix. We did this because otherwise the system is unsolvable; technically the determinant of the stiffness matrix is zero. This mathematically represents the fact that until we apply boundary conditions, the structure is floating in space.

To impose known displacements (i.e. supports) on the structure equations we modify the global stiffness matrix and the force vector so that we get back the zero displacement result we know.

Considering our two-element example again, if node 1 is supported, $u_1 = 0$. Consider the system equation:

$$\begin{Bmatrix} F_1 \\ F_2 \\ F_3 \end{Bmatrix} = \begin{bmatrix} K_{11} & K_{21} & K_{13} \\ K_{21} & K_{22} & K_{23} \\ K_{31} & K_{32} & K_{33} \end{bmatrix} \begin{Bmatrix} u_1 \\ u_2 \\ u_3 \end{Bmatrix} \quad (1.26)$$

Therefore to obtain $u_1 = 0$ from this, we change \mathbf{K} and \mathbf{F} as follows:

$$\begin{Bmatrix} 0 \\ F_2 \\ F_3 \end{Bmatrix} = \begin{bmatrix} 1 & 0 & 0 \\ 0 & K_{22} & K_{23} \\ 0 & K_{32} & K_{33} \end{bmatrix} \begin{Bmatrix} u_1 \\ u_2 \\ u_3 \end{Bmatrix} \quad (1.27)$$

Now when we solve for u_1 we will get the answer we want: $u_1 = 0$. In fact, since we now do not need this first equation, we could just consider the remaining equations:

$$\begin{Bmatrix} F_2 \\ F_3 \end{Bmatrix} = \begin{bmatrix} K_{22} & K_{23} \\ K_{32} & K_{33} \end{bmatrix} \begin{Bmatrix} u_2 \\ u_3 \end{Bmatrix} \quad (1.28)$$

And these are perfectly solvable.

Thus to summarize:

To impose a support condition at degree of freedom i :

1. Make the force vector element of DOF i zero;
2. Make the i column and row entries of the stiffness matrix all zero;
3. Make the diagonal entry (i,i) of the stiffness matrix 1.

2. Plane Trusses

2.1 Introduction

Trusses are assemblies of members whose actions can be linked directly to that of the simple spring studied already:

$$k = \frac{EA}{L} \quad (2.1)$$

There is one main difference, however: truss members may be oriented at any angle in the xy coordinate system (Cartesian) plane:

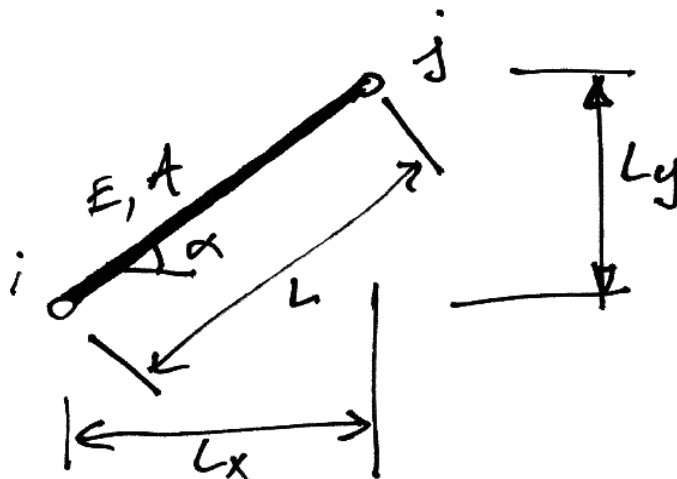

Thus we must account for the coordinate transformations from the local member axis system to the global axis system.

2.2 Truss Element Stiffness Matrix

For many element types it is very difficult to express the element stiffness matrix in global coordinates. However, this is not so for truss elements. Firstly we note that the local axis system element stiffness matrix is given by equation (1.3):

$$[\mathbf{k}] = \begin{bmatrix} k & -k \\ -k & k \end{bmatrix} = k \begin{bmatrix} 1 & -1 \\ -1 & 1 \end{bmatrix} \quad (2.2)$$

Next, introducing equation (2.1), we have:

$$[\mathbf{k}] = \frac{EA}{L} \begin{bmatrix} 1 & -1 \\ -1 & 1 \end{bmatrix} \quad (2.3)$$

However, this equation was written for a 1-dimensional element. Expanding this to a two-dimensional axis system is straightforward since there are no y-axis values:

$$[\mathbf{k}] = \frac{EA}{L} \begin{bmatrix} 1 & 0 & -1 & 0 \\ 0 & 0 & 0 & 0 \\ -1 & 0 & 1 & 0 \\ 0 & 0 & 0 & 0 \end{bmatrix} \begin{matrix} \leftarrow x_i \\ \leftarrow y_i \\ \leftarrow x_j \\ \leftarrow y_j \end{matrix} \quad (2.4)$$

Next, using the general element stiffness transformation equation (See the Appendix):

$$[\mathbf{k}] = [\mathbf{T}]^T [\mathbf{k}] [\mathbf{T}] \quad (2.5)$$

And noting the transformation matrix for a plane truss element from the Appendix:

$$\mathbf{T} = \begin{bmatrix} \mathbf{T}_p & \mathbf{0} \\ \mathbf{0} & \mathbf{T}_p \end{bmatrix} = \begin{bmatrix} \cos \alpha & \sin \alpha & 0 & 0 \\ -\sin \alpha & \cos \alpha & 0 & 0 \\ 0 & 0 & \cos \alpha & \sin \alpha \\ 0 & 0 & -\sin \alpha & \cos \alpha \end{bmatrix} \quad (2.6)$$

We have:

$$[\mathbf{k}] = \frac{EA}{L} \begin{bmatrix} \cos \alpha & \sin \alpha & 0 & 0 \\ -\sin \alpha & \cos \alpha & 0 & 0 \\ 0 & 0 & \cos \alpha & \sin \alpha \\ 0 & 0 & -\sin \alpha & \cos \alpha \end{bmatrix}^{-1} \begin{bmatrix} 1 & 0 & -1 & 0 \\ 0 & 0 & 0 & 0 \\ -1 & 0 & 1 & 0 \\ 0 & 0 & 0 & 0 \end{bmatrix}. \quad (2.7)$$

$$\begin{bmatrix} \cos \alpha & \sin \alpha & 0 & 0 \\ -\sin \alpha & \cos \alpha & 0 & 0 \\ 0 & 0 & \cos \alpha & \sin \alpha \\ 0 & 0 & -\sin \alpha & \cos \alpha \end{bmatrix}$$

Carrying out the multiplication gives:

$$\mathbf{k} = \frac{EA}{L} \left[\begin{array}{cc|cc} \cos^2 \alpha & \cos \alpha \sin \alpha & -\cos^2 \alpha & -\cos \alpha \sin \alpha \\ \cos \alpha \sin \alpha & \sin^2 \alpha & -\cos \alpha \sin \alpha & -\sin^2 \alpha \\ \hline -\cos^2 \alpha & -\cos \alpha \sin \alpha & \cos^2 \alpha & \cos \alpha \sin \alpha \\ -\cos \alpha \sin \alpha & -\sin^2 \alpha & \cos \alpha \sin \alpha & \sin^2 \alpha \end{array} \right] \quad (2.8)$$

If we examine the nodal sub-matrices and write $c \equiv \cos \alpha$, $s \equiv \sin \alpha$:

$$[\mathbf{k}] = \frac{EA}{L} \left[\begin{array}{cc|cc} c^2 & cs & -c^2 & -cs \\ cs & s^2 & -cs & -s^2 \\ \hline -c^2 & -cs & c^2 & cs \\ -cs & -s^2 & cs & s^2 \end{array} \right] \quad (2.9)$$

Labelling the **nodal sub-matrices** as:

$$[\mathbf{k}] = \begin{bmatrix} \mathbf{k11} & \mathbf{k12} \\ \mathbf{k21} & \mathbf{k22} \end{bmatrix} \quad (2.10)$$

Then we see that the sub-matrices are of dimension 2×2 (No. DOF \times No. DOF) and are:

$$\mathbf{k11} = \frac{EA}{L} \begin{bmatrix} c^2 & cs \\ cs & s^2 \end{bmatrix} \quad (2.11)$$

And also note:

$$\mathbf{k11} = \mathbf{k22} = -\mathbf{k12} = -\mathbf{k21} \quad (2.12)$$

Therefore, we need only evaluate a single nodal sub-matrix (**k11**) in order to find the total element stiffness matrix in global coordinates.

2.3 Element Forces

The forces applied to a member's ends are got from the element equation:

$$\{\mathbf{F}^e\} = [\mathbf{k}]\{\mathbf{u}^e\} \quad (2.13)$$

Expanding this in terms of nodal equations we have:

$$\begin{Bmatrix} \mathbf{F}_i \\ \mathbf{F}_j \end{Bmatrix} = \begin{bmatrix} \mathbf{k11} & \mathbf{k12} \\ \mathbf{k21} & \mathbf{k22} \end{bmatrix} \begin{Bmatrix} \delta_i \\ \delta_j \end{Bmatrix} \quad (2.14)$$

Thus we know:

$$\mathbf{F}_j = \mathbf{k21} \cdot \delta_i + \mathbf{k22} \cdot \delta_j \quad (2.15)$$

From which we could determine the member's axial force. However, for truss members, we can determine a simple expression to use if we consider the change in length in terms of the member end displacements:

$$\Delta L_x = \delta_{jx} - \delta_{ix} \quad (2.16)$$

$$\Delta L_y = \delta_{jy} - \delta_{iy} \quad (2.17)$$

And using the coordinate transforms idea:

$$\Delta L = \Delta L_x \cos \alpha + \Delta L_y \sin \alpha \quad (2.18)$$

Also we know that the member force is related to the member elongation by:

$$F = \frac{EA}{L} \cdot \Delta L \quad (2.19)$$

Thus we have:

$$F = \frac{EA}{L} \cdot [\Delta L_x \cos \alpha + \Delta L_y \sin \alpha] \quad (2.20)$$

And introducing equations (2.16) and (2.17) gives:

$$F = \frac{EA}{L} \cdot [\cos \alpha \quad \sin \alpha] \begin{Bmatrix} \delta_{jx} - \delta_{ix} \\ \delta_{jy} - \delta_{iy} \end{Bmatrix} \quad (2.21)$$

A positive result from this means tension and negative compression.

2.4 Example 2: Basic Truss

Problem

Analyse the following truss using the stiffness matrix method.

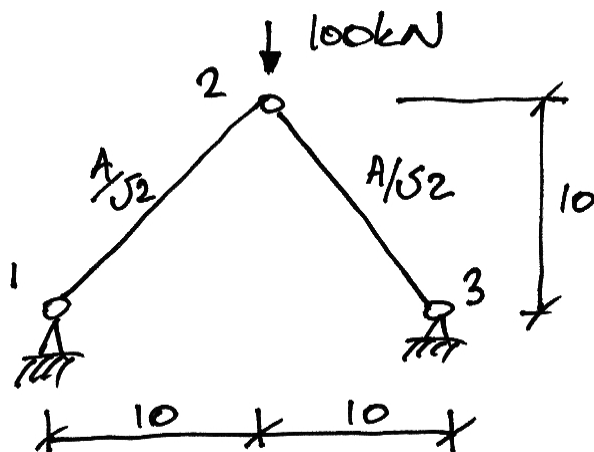

Note that:

- $E = 200 \text{ kN/mm}^2$;
- The reference area is $A = 100 \text{ mm}^2$.

Solution

STEP 1: Determine the member stiffness matrices:

Member 12

The angle this member makes to the global axis system and the relevant values are:

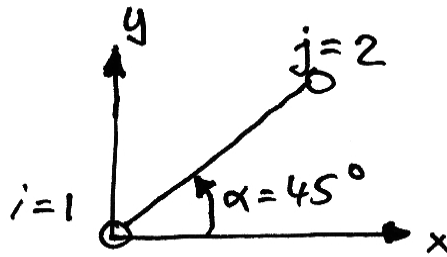

$$c \equiv \cos \alpha = \cos 45^\circ = \frac{1}{\sqrt{2}} \Rightarrow c^2 = \frac{1}{2}$$

$$s \equiv \sin \alpha = \sin 45^\circ = \frac{1}{\sqrt{2}} \Rightarrow s^2 = \frac{1}{2} \Rightarrow cs = \frac{1}{2}$$

Therefore:

$$\mathbf{k11}_{12} = \left(\frac{EA}{L} \right)_{12} \begin{bmatrix} c^2 & cs \\ cs & s^2 \end{bmatrix} = \frac{200 \cdot 100 / \sqrt{2}}{10\sqrt{2}} \begin{bmatrix} 0.5 & 0.5 \\ 0.5 & 0.5 \end{bmatrix}$$

Thus:

$$\mathbf{k11}_{12} = 10^3 \begin{bmatrix} 0.5 & 0.5 \\ 0.5 & 0.5 \end{bmatrix} \quad (2.22)$$

Notice that the matrix is symmetrical as it should be.

Member 23

The angle this member makes to the global axis system and the relevant values are:

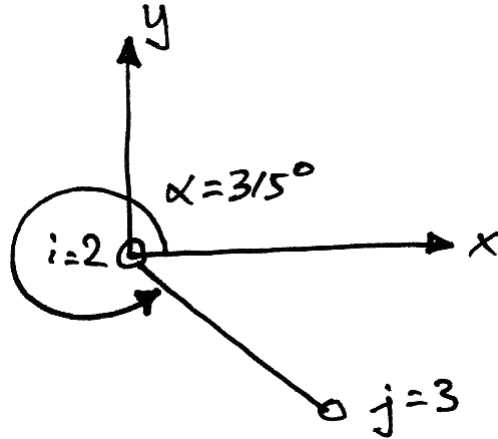

$$c \equiv \cos \alpha = \cos 45^\circ = \frac{1}{\sqrt{2}} \Rightarrow c^2 = \frac{1}{2}$$

$$s \equiv \sin \alpha = \sin 45^\circ = -\frac{1}{\sqrt{2}} \Rightarrow s^2 = \frac{1}{2} \Rightarrow cs = -\frac{1}{2}$$

Therefore:

$$\mathbf{k11}_{23} = \left(\frac{EA}{L} \right)_{23} \begin{bmatrix} c^2 & cs \\ cs & s^2 \end{bmatrix} = \frac{200 \cdot 100 / \sqrt{2}}{10\sqrt{2}} \begin{bmatrix} 0.5 & -0.5 \\ -0.5 & 0.5 \end{bmatrix}$$

Thus:

$$\mathbf{k11}_{23} = 10^3 \begin{bmatrix} 0.5 & -0.5 \\ -0.5 & 0.5 \end{bmatrix} \quad (2.23)$$

Again the matrix is symmetrical.

STEP 2: Assemble the global stiffness matrix

For 3 nodes, the unrestricted global stiffness matrix will look as follows:

$$\mathbf{K} = \begin{bmatrix} \mathbf{K}_{11} & \mathbf{K}_{12} & \mathbf{K}_{13} \\ \mathbf{K}_{21} & \mathbf{K}_{22} & \mathbf{K}_{23} \\ \mathbf{K}_{31} & \mathbf{K}_{32} & \mathbf{K}_{33} \end{bmatrix} \begin{array}{l} \leftarrow \text{Node 1} \\ \leftarrow \text{Node 2} \\ \leftarrow \text{Node 3} \end{array} \quad (2.24)$$

Note that each of the sub-matrices is a 2×2 matrix, e.g.:

$$\mathbf{K}_{11} = \begin{bmatrix} k_{11,xx} & k_{12,xy} \\ k_{21,yx} & k_{22,yy} \end{bmatrix} \begin{array}{l} \leftarrow \text{Node 1 } x \\ \leftarrow \text{Node 1 } y \end{array} \quad (2.25)$$

The member stiffness nodal sub-matrices contribute to the global stiffness nodal sub-matrices as follows:

$$\mathbf{K} = \begin{bmatrix} \mathbf{K}_{11} & \mathbf{K}_{12} & \mathbf{K}_{13} \\ \mathbf{K}_{21} & \mathbf{K}_{22} & \mathbf{K}_{23} \\ \mathbf{K}_{31} & \mathbf{K}_{32} & \mathbf{K}_{33} \end{bmatrix} = \begin{bmatrix} \mathbf{k11}_{12} & \mathbf{k12}_{12} & \mathbf{0} \\ \mathbf{k21}_{12} & \mathbf{k22}_{12} + \mathbf{k11}_{23} & \mathbf{k12}_{23} \\ \mathbf{0} & \mathbf{k21}_{23} & \mathbf{k22}_{23} \end{bmatrix} \quad (2.26)$$

Expanding this out and filling in the relevant entries from equations (2.22) and (2.23) whilst using equation (2.12) gives:

$$\mathbf{K} = 10^3 \begin{bmatrix} 0.5 & 0.5 & -0.5 & 0.5 & 0 & 0 \\ 0.5 & 0.5 & 0.5 & -0.5 & 0 & 0 \\ \hline -0.5 & 0.5 & 1 & 0 & -0.5 & 0.5 \\ 0.5 & -0.5 & 0 & 1 & 0.5 & -0.5 \\ \hline 0 & 0 & -0.5 & 0.5 & 0.5 & -0.5 \\ 0 & 0 & 0.5 & -0.5 & -0.5 & 0.5 \end{bmatrix} \quad (2.27)$$

STEP 3: Write the solution equation in full

$$\{\mathbf{F}\} = [\mathbf{K}]\{\boldsymbol{\delta}\} \quad (2.28)$$

Thus, keeping the nodal sub-matrices identifiable for clarity:

$$\begin{Bmatrix} R_{1x} \\ R_{1y} \\ \hline 0 \\ -100 \\ \hline R_{3x} \\ R_{3y} \end{Bmatrix} = 10^3 \begin{bmatrix} 0.5 & 0.5 & -0.5 & 0.5 & 0 & 0 \\ 0.5 & 0.5 & 0.5 & -0.5 & 0 & 0 \\ \hline -0.5 & 0.5 & 1 & 0 & -0.5 & 0.5 \\ 0.5 & -0.5 & 0 & 1 & 0.5 & -0.5 \\ \hline 0 & 0 & -0.5 & 0.5 & 0.5 & -0.5 \\ 0 & 0 & 0.5 & -0.5 & -0.5 & 0.5 \end{bmatrix} \begin{Bmatrix} \delta_{1x} \\ \delta_{1y} \\ \hline \delta_{2x} \\ \delta_{2y} \\ \hline \delta_{3x} \\ \delta_{3y} \end{Bmatrix} \quad (2.29)$$

In which we have noted:

- R_{1x} is the reaction at node 1 in the x -direction (and similarly for the others);
- The force at node 2 is 0 in the x -direction and -100 kN (downwards) in the y -direction.

STEP 4: Restrict the equation.

Now we impose the boundary conditions on the problem. We know:

- $\delta_{1x} = \delta_{1y} = 0$ since node 1 is pinned;
- $\delta_{3x} = \delta_{3y} = 0$ again, since node 3 is pinned.

Thus equation (2.29) becomes:

$$\begin{Bmatrix} 0 \\ 0 \\ -100 \\ 0 \\ 0 \end{Bmatrix} = 10^3 \begin{bmatrix} 1 & 0 & 0 & 0 & 0 & 0 \\ 0 & 1 & 0 & 0 & 0 & 0 \\ 0 & 0 & 1 & 0 & 0 & 0 \\ 0 & 0 & 0 & 1 & 0 & 0 \\ 0 & 0 & 0 & 0 & 1 & 0 \\ 0 & 0 & 0 & 0 & 0 & 1 \end{bmatrix} \begin{Bmatrix} \delta_{1x} \\ \delta_{1y} \\ \delta_{2x} \\ \delta_{2y} \\ \delta_{3x} \\ \delta_{3y} \end{Bmatrix} \quad (2.30)$$

Since both DOFs are restricted for nodes 1 and 3, we can thus write the remaining equations for node 2:

$$\begin{Bmatrix} 0 \\ -100 \end{Bmatrix} = 10^3 \begin{bmatrix} 1 & 0 \\ 0 & 1 \end{bmatrix} \begin{Bmatrix} \delta_{2x} \\ \delta_{2y} \end{Bmatrix} \quad (2.31)$$

STEP 5: Solve the system

The y-direction is thus the only active equation:

$$-100 = 10^3 \delta_{2y} \quad (2.32)$$

Thus:

$$\delta_{2y} = -0.1 \text{ m} = 100 \text{ mm} \downarrow \quad (2.33)$$

STEP 6: Determine the member forces

For truss member's we outlined a simple method encompassed in equation (2.21). In applying this to Member 12 we note:

- $\delta_{1,x} = \delta_{1,y} = 0$ since it is a support;
- $\delta_{2,x} = 0$ by solution;
- $\delta_{2,y} = -0.1$ again by solution.

Thus:

$$F = \frac{EA}{L} \cdot [\cos \alpha \quad \sin \alpha] \begin{Bmatrix} \delta_{jx} - \delta_{ix} \\ \delta_{jy} - \delta_{iy} \end{Bmatrix}$$

$$F = 10^3 \left[\frac{1}{\sqrt{2}} \quad \frac{1}{\sqrt{2}} \right] \begin{Bmatrix} 0 - 0 \\ -0.1 - 0 \end{Bmatrix} = -\frac{100}{\sqrt{2}} = -50\sqrt{2} \text{ kN} \quad (2.34)$$

And so Member 12 is in compression, as may be expected. For Member 23 we similarly have:

$$F = 10^3 \left[\frac{1}{\sqrt{2}} \quad -\frac{1}{\sqrt{2}} \right] \begin{Bmatrix} 0 - 0 \\ 0 - (-0.1) \end{Bmatrix} = -\frac{100}{\sqrt{2}} = -50\sqrt{2} \text{ kN} \quad (2.35)$$

And again Member 23 is in compression. Further, since the structure is symmetrical and is symmetrically loaded, it makes sense that Member's 12 and 23 have the same force.

STEP 7: Determine the reactions

To determine the remaining unknown forces we can use the basic equation now that all displacements are known:

$$\begin{Bmatrix} R_{1x} \\ R_{1y} \\ 0 \\ -100 \\ R_{3x} \\ R_{3y} \end{Bmatrix} = 10^3 \begin{bmatrix} 0.5 & 0.5 & -0.5 & 0.5 & 0 & 0 \\ 0.5 & 0.5 & 0.5 & -0.5 & 0 & 0 \\ -0.5 & 0.5 & 1 & 0 & -0.5 & 0.5 \\ 0.5 & -0.5 & 0 & 1 & 0.5 & -0.5 \\ 0 & 0 & -0.5 & 0.5 & 0.5 & -0.5 \\ 0 & 0 & 0.5 & -0.5 & -0.5 & 0.5 \end{bmatrix} \begin{Bmatrix} 0 \\ 0 \\ 0 \\ -0.1 \\ 0 \\ 0 \end{Bmatrix} \quad (2.36)$$

Thus we have:

$$R_{1x} = [-0.5 \quad 0.5] \begin{Bmatrix} 0 \\ -0.1 \end{Bmatrix} = -50 \text{ kN} \quad (2.37)$$

$$R_{1y} = [0.5 \quad -0.5] \begin{Bmatrix} 0 \\ -0.1 \end{Bmatrix} = +50 \text{ kN} \quad (2.38)$$

$$R_{3x} = [-0.5 \quad 0.5] \begin{Bmatrix} 0 \\ -0.1 \end{Bmatrix} = -50 \text{ kN} \quad (2.39)$$

$$R_{3y} = [0.5 \quad -0.5] \begin{Bmatrix} 0 \\ -0.1 \end{Bmatrix} = +50 \text{ kN} \quad (2.40)$$

Again note that the sign indicates the direction along the global coordinate system.

We can now plot the full solution:

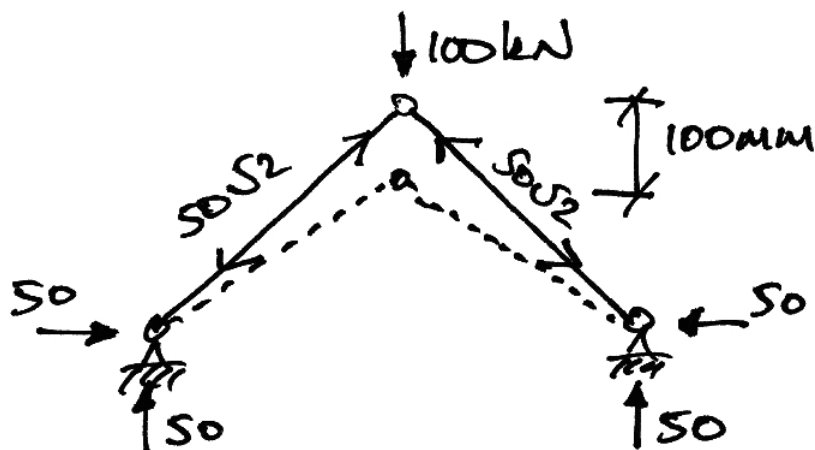

2.5 Example 3: Adding Members

Problem

Analyse the truss of Example 2 but with the following member 14 added:

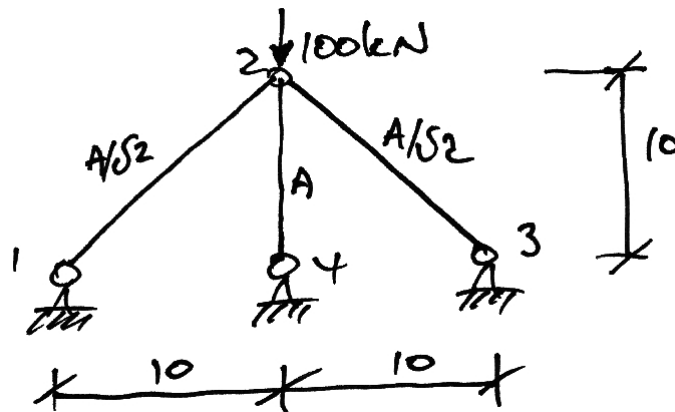

Solution

With the addition of node 4 we now know that the nodal sub-matrices global stiffness equation will be 4×4 with the fully expanded matrix being 16×16 . Rather than determine every entry in this, let's restrict it now and only determine the values we will actually use. Since nodes 1, 3 and 4 are pinned, all their DOFs are fully restricted out. The restricted equation thus becomes:

$$\{\mathbf{F}_2\} = [\mathbf{K22}]\{\delta_2\} \quad (2.41)$$

Next we must identify the contributions from each member:

- We already know the contributions of Members 12 and 23 from Example 2.
- The contribution of Member 24 is to nodes 2 and 4. Since node 4 is restricted, we only have the contribution $\mathbf{k11}_{24}$ to $\mathbf{K22}$.

Thus $\mathbf{K22}$ becomes:

$$\mathbf{K22} = \mathbf{k22}_{12} + \mathbf{k11}_{23} + \mathbf{k11}_{24} \quad (2.42)$$

Next determine $\mathbf{k11}_{24}$: this member makes an angle of 270° to the global axis system giving:

$$c \equiv \cos \alpha = \cos 270^\circ = 0 \quad \Rightarrow c^2 = 0$$

$$s \equiv \sin \alpha = \sin 270^\circ = -1 \quad \Rightarrow s^2 = 1 \quad \Rightarrow cs = 0$$

Therefore:

$$\mathbf{k11}_{24} = \left(\frac{EA}{L} \right)_{24} \begin{bmatrix} c^2 & cs \\ cs & s^2 \end{bmatrix} = \frac{200 \cdot 100}{10} \begin{bmatrix} 0 & 0 \\ 0 & 1 \end{bmatrix}$$

Thus:

$$\mathbf{k11}_{24} = 10^3 \begin{bmatrix} 0 & 0 \\ 0 & 2 \end{bmatrix} \quad (2.43)$$

Hence the global restricted stiffness matrix becomes:

$$\mathbf{K22} = 10^3 \begin{bmatrix} 1 & 0 \\ 0 & 1 \end{bmatrix} + 10^3 \begin{bmatrix} 0 & 0 \\ 0 & 2 \end{bmatrix} = 10^3 \begin{bmatrix} 1 & 0 \\ 0 & 3 \end{bmatrix} \quad (2.44)$$

Writing the restricted equation, we have:

$$\begin{Bmatrix} 0 \\ -100 \end{Bmatrix} = 10^3 \begin{bmatrix} 1 & 0 \\ 0 & 3 \end{bmatrix} \begin{Bmatrix} \delta_{2x} \\ \delta_{2y} \end{Bmatrix} \quad (2.45)$$

From which we find the only equation

$$-100 = 10^3 (3\delta_{2y}) \quad (2.46)$$

Thus:

$$\delta_{2y} = -0.033 \text{ m} = 33.3 \text{ mm} \downarrow \quad (2.47)$$

The member forces are:

$$F_{12} = 10^3 \begin{bmatrix} 1 & 1 \\ \sqrt{2} & \sqrt{2} \end{bmatrix} \begin{Bmatrix} 0-0 \\ -0.033-0 \end{Bmatrix} = -23.6 \text{ kN} \quad (2.48)$$

$$F_{23} = 10^3 \begin{bmatrix} 1 & -1 \\ \sqrt{2} & -\sqrt{2} \end{bmatrix} \begin{Bmatrix} 0-0 \\ 0-(-0.033) \end{Bmatrix} = -23.6 \text{ kN} \quad (2.49)$$

$$F_{24} = 10^3 \begin{bmatrix} 0 & 2 \end{bmatrix} \begin{Bmatrix} 0-0 \\ -0.033-0 \end{Bmatrix} = -66.6 \text{ kN} \quad (2.50)$$

Thus we have the following solution:

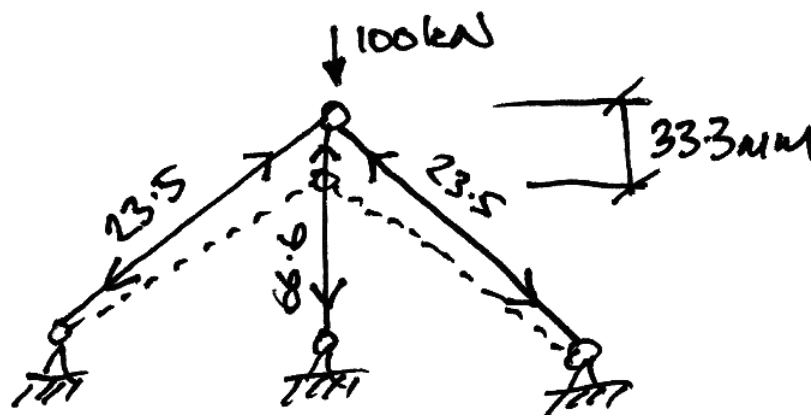

2.6 Example 4: Using Symmetry

Problem

Analyse the truss of Example 3 taking advantage of any symmetry:

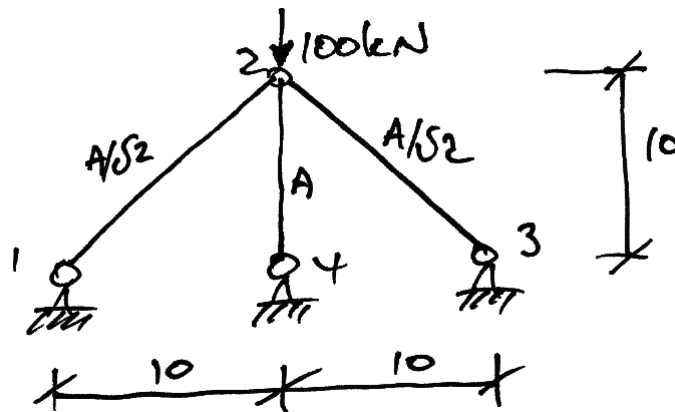

Solution

Looking at the structure it is clear that by splitting the structure down the middle along member 24 that we will have two equal halves:

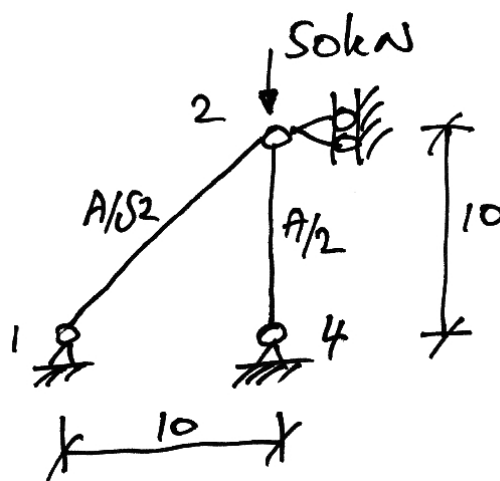

Notice that we have changed the following:

- The load is halved since it is now equally shared amongst two halves;
- Similarly the area of member 24 is halved.

We now analyse this new truss as usual. However, we can make use of some previous results. For Member 12:

$$\mathbf{k11}_{12} = 10^3 \begin{bmatrix} 0.5 & 0.5 \\ 0.5 & 0.5 \end{bmatrix} \quad (2.51)$$

And for Member 24

$$\mathbf{k11}_{24} = \frac{1}{2} \left\{ 10^3 \begin{bmatrix} 0 & 0 \\ 0 & 2 \end{bmatrix} \right\} = 10^3 \begin{bmatrix} 0 & 0 \\ 0 & 1 \end{bmatrix} \quad (2.52)$$

Since the area is halved from that of Example 3, its stiffnesses are halved.

In restricting we note that the only possible displacement is node 2 in the y-direction. However, we will keep using the node 2 sub-matrices until the last moment:

$$\mathbf{K22} = 10^3 \begin{bmatrix} 0.5 & 0 \\ 0 & 0.5 \end{bmatrix} + 10^3 \begin{bmatrix} 0 & 0 \\ 0 & 1 \end{bmatrix} = 10^3 \begin{bmatrix} 0.5 & 0 \\ 0 & 1.5 \end{bmatrix} \quad (2.53)$$

Thus:

$$\begin{Bmatrix} 0 \\ -50 \end{Bmatrix} = 10^3 \begin{bmatrix} 0.5 & 0 \\ 0 & 1.5 \end{bmatrix} \begin{Bmatrix} \delta_{2x} \\ \delta_{2y} \end{Bmatrix} \quad (2.54)$$

And now imposing the boundary condition $\delta_{2x} = 0$:

$$\{-50\} = 10^3 [1.5] \{\delta_{2,y}\} \quad (2.55)$$

From which we solve for the displacement:

$$\begin{aligned} \{-50\} &= 10^3 [1.5] \{ \} \\ \delta_{2,y} &= -0.033 \text{ m} = 33.3 \text{ mm} \downarrow \end{aligned} \quad (2.56)$$

This (of course) is the same result we obtained in Example 3. For the member forces we have:

$$F_{12} = 10^3 \begin{bmatrix} 1 & 1 \\ \sqrt{2} & \sqrt{2} \end{bmatrix} \begin{Bmatrix} 0-0 \\ -0.033-0 \end{Bmatrix} = -23.6 \text{ kN} \quad (2.57)$$

$$F_{24} = 10^3 [0 \quad 1] \begin{Bmatrix} 0-0 \\ -0.033-0 \end{Bmatrix} = -33.3 \text{ kN} \quad (2.58)$$

Member 12 has the same force as per Example 3 as is expected.

It might appear that Member 24 has an erroneous force result. It must be remembered that this is the force in the half-member (brought about since we are using symmetry). Therefore the force in the full member is $2 \times 33.3 = 66.6 \text{ kN}$ as per Example 3.

2.7 Self-Strained Structures

Introduction

A self-strained structure is one where strains are induced by sources other than externally applied loads. The two main examples are temperature difference and lack of fit of a member. For example consider the effect if member 13 in the following structure was too long and had to be 'squeezed' into place:

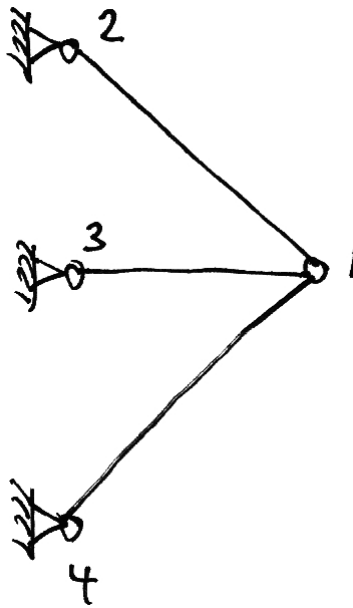

It should be intuitively obvious that to 'squeeze' the member into place a compressive force was required to shorten it to the required length:

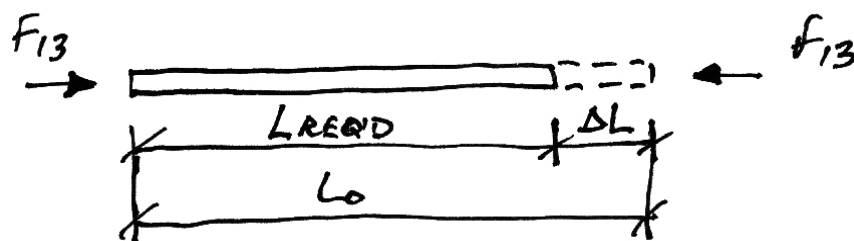

Once the member has been put in place, the source of the 'squeezing' is removed. Since the member wants to spring back to its original length, it pushes on its joints:

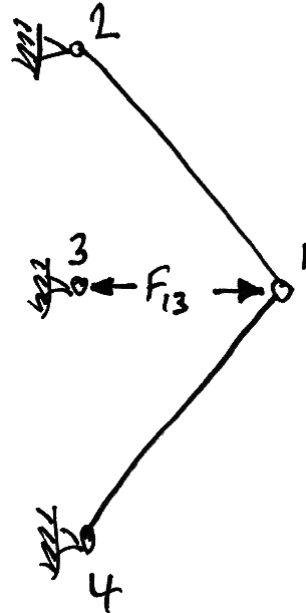

In this way members 12 and 14 will now go into tension whilst member 13 will remain in compression, but a smaller compression than when it was 'squeezed' into place since joint 1 will deflect to the right some amount.

In a similar way to lack of fit, examined above, if member 13 had been subject to a temperature increase it would try to elongate. However this elongation is restrained by the other members inducing them into tension and member 13 into some compression.

Lack of Fit

We consider a member with original length of L_o that is required to be of length $L_{\text{Req'd}}$. Thus a change in length of ΔL must be applied:

$$L_{\text{Req'd}} = L_o + \Delta L \quad (2.59)$$

Thus:

- ΔL is positive: the member is too short and must be lengthened to get into place;
- ΔL is negative, it is too long and must be shortened to get into place.

Thus we must apply a force to the member that will cause a change in length of ΔL . From basic mechanics:

$$\Delta L = \frac{FL_o}{EA} \quad (2.60)$$

Thus the force required is:

$$F = EA \cdot \frac{\Delta L}{L_o} \quad (2.61)$$

From the above sign convention for ΔL :

- F is positive when the member must be put into tension to get it in place;
- F is negative when the member must be put into compression to get it in place.

Lastly, remember to apply the member force in *opposite direction* to the member's nodes.

Temperature Change

We consider a member that is subject to a differential (i.e. different to the rest of the structure) temperature change of ΔT degrees Celsius. Also we must know the coefficient of linear thermal expansion, α , for the material. This is the change in length, per unit length, per unit change in temperature:

$$\alpha \equiv \left(\frac{\Delta L}{L_o} \right) / ^\circ C \quad (2.62)$$

Thus the thermal strain induced in the member is:

$$\varepsilon_T = \alpha \Delta T \quad (2.63)$$

And so the change in length is:

$$\Delta L = \alpha L_o \Delta T \quad (2.64)$$

Also, since $\sigma = E\varepsilon$, we find the force in the member:

$$F_T = \sigma_T A = EA\varepsilon_T \quad (2.65)$$

So finally, from equation (2.63), the force required to suppress the temperature change is:

$F_T = EA\alpha \Delta T \quad (2.66)$
--

Once again, apply this force in the opposite direction to the member's nodes.

2.8 Example 5 – Truss with Differential Temperature

Problem

Member 13 of the following truss is subject to a temperature change of $+100\text{ }^{\circ}\text{C}$. Calculate the deflections of node 1 and the final forces in the members.

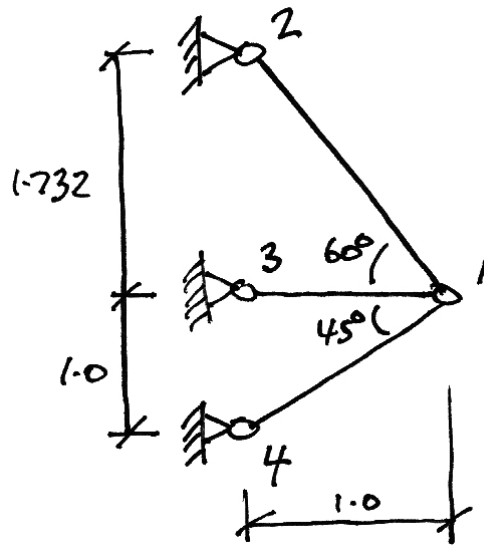

Take: $\alpha = 2 \times 10^{-5}\text{ }^{\circ}\text{C}^{-1}$; $EA = 2 \times 10^4\text{ kN}$; the area of member 12 as $2A$; the area of member 13 as A ; and, the area of member 14 as $A\sqrt{2}$.

Solution

First we must recognize that there are two stages to the actions in the members:

- Stage I: all displacements are suppressed and only the temperature force in member 13 is allowed for;
- Stage II: displacements are allowed and the actions of the temperature force in member 13 upon the rest of the structure are analyzed for.

The final result is then the summation of these two stages:

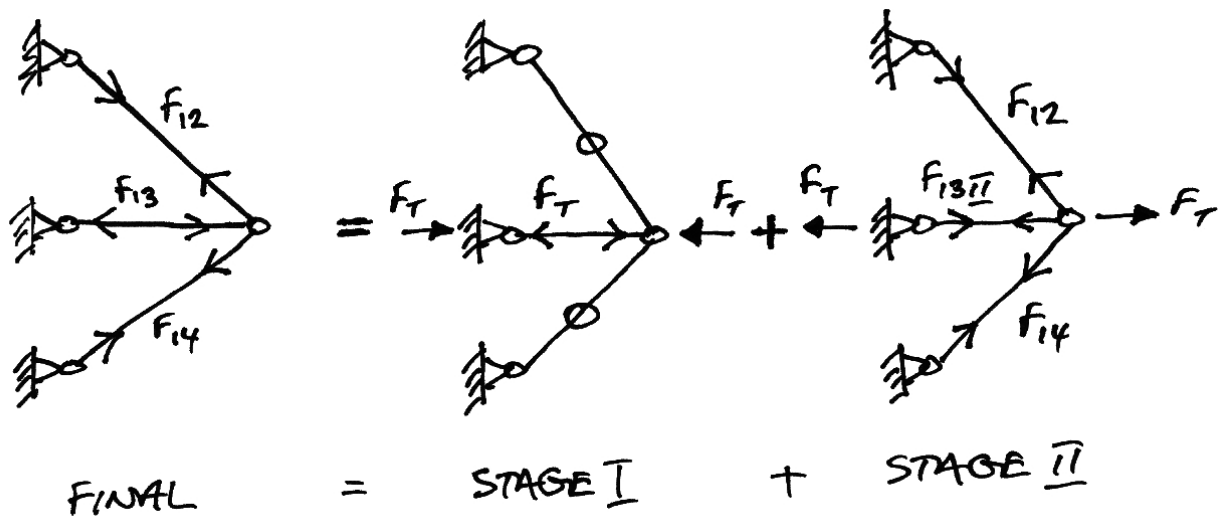

The force induced in member 13 when displacements are suppressed is:

$$\begin{aligned}
 F_T &= EA\alpha \Delta T \\
 &= (2 \times 10^4)(2 \times 10^{-5})(+100) \\
 &= 40 \text{ kN}
 \end{aligned}
 \tag{2.67}$$

Stage I

All displacements are suppressed. Thus:

$$\delta_{1x} = 0; \quad \delta_{1y} = 0 \quad (2.68)$$

$$F'_{12} = 0; \quad F'_{13} = F_T; \quad F'_{14} = 0 \quad (2.69)$$

Stage II

Displacements are allowed occur and thus we must analyse the truss. Using the matrix stiffness method, and recognizing that only joint 1 can displace, we have:

$$\{\mathbf{F}_1\} = [\mathbf{K11}]\{\delta_1\} \quad (2.70)$$

Also, since we cleverly chose the node numbers, the member contributions are just:

$$\mathbf{K11} = \mathbf{k11}_{12} + \mathbf{k11}_{13} + \mathbf{k11}_{14} \quad (2.71)$$

- Member 12:

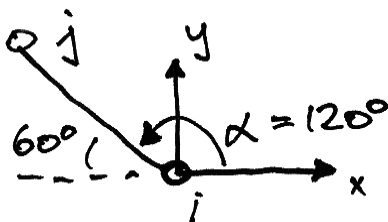

$$c \equiv \cos \alpha = \cos 120^\circ = -\frac{1}{2} \Rightarrow c^2 = \frac{1}{4}$$

$$s \equiv \sin \alpha = \sin 120^\circ = \frac{\sqrt{3}}{2} \Rightarrow s^2 = \frac{3}{4} \Rightarrow cs = -\frac{\sqrt{3}}{4}$$

$$\mathbf{k11}_{12} = \left(\frac{EA}{L} \right)_{23} \begin{bmatrix} c^2 & cs \\ cs & s^2 \end{bmatrix} = \frac{2 \times 10^4 (2)}{2.0} \begin{bmatrix} \frac{1}{4} & -\frac{\sqrt{3}}{4} \\ -\frac{\sqrt{3}}{4} & \frac{3}{4} \end{bmatrix}$$

- Member 13:

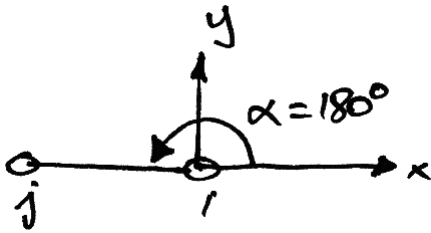

$$c \equiv \cos \alpha = \cos 180^\circ = -1 \Rightarrow c^2 = 1$$

$$s \equiv \sin \alpha = \sin 180^\circ = 0 \Rightarrow s^2 = 0 \Rightarrow cs = 0$$

$$\mathbf{k11}_{13} = \left(\frac{EA}{L} \right)_{23} \begin{bmatrix} c^2 & cs \\ cs & s^2 \end{bmatrix} = \frac{2 \times 10^4}{1.0} \begin{bmatrix} 1 & 0 \\ 0 & 0 \end{bmatrix}$$

- Member 14:

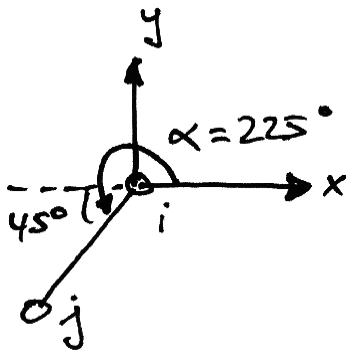

$$c \equiv \cos \alpha = \cos 225^\circ = -\frac{1}{\sqrt{2}} \Rightarrow c^2 = \frac{1}{2}$$

$$s \equiv \sin \alpha = \sin 225^\circ = -\frac{1}{\sqrt{2}} \Rightarrow s^2 = \frac{1}{2} \Rightarrow cs = \frac{1}{2}$$

$$\mathbf{k11}_{14} = \left(\frac{EA}{L} \right)_{23} \begin{bmatrix} c^2 & cs \\ cs & s^2 \end{bmatrix} = \frac{2 \times 10^4 (\sqrt{2})}{1.0 \sqrt{2}} \begin{bmatrix} 0.5 & 0.5 \\ 0.5 & 0.5 \end{bmatrix}$$

Thus from equation (2.71) we have:

$$\mathbf{K11} = \frac{2 \times 10^4}{4} \begin{bmatrix} 7 & 2 - \sqrt{3} \\ 2 - \sqrt{3} & 5 \end{bmatrix} \quad (2.72)$$

From the diagram for Stage II, we can see that the force applied to joint 1 is acting to the right and so is positive. Thus:

$$\begin{Bmatrix} 40 \\ 0 \end{Bmatrix} = \frac{2 \times 10^4}{4} \begin{bmatrix} 7 & 2 - \sqrt{3} \\ 2 - \sqrt{3} & 5 \end{bmatrix} \begin{Bmatrix} \delta_{1x} \\ \delta_{1y} \end{Bmatrix} \quad (2.73)$$

Solve this to get:

$$\begin{Bmatrix} \delta_{1x} \\ \delta_{1y} \end{Bmatrix} = \frac{4}{2 \times 10^4} \frac{1}{\begin{bmatrix} 5 & \sqrt{3} - 2 \\ \sqrt{3} - 2 & 7 \end{bmatrix}} \begin{Bmatrix} 40 \\ 0 \end{Bmatrix} \quad (2.74)$$

$$= 10^{-3} \begin{Bmatrix} 1.15 \\ -0.06 \end{Bmatrix} \text{ m}$$

Using equation (2.21) we can now find the member forces for Stage II:

$$F_{12}'' = \frac{2 \times 10^4}{2.0} \cdot \begin{bmatrix} -\frac{1}{2} & \frac{\sqrt{3}}{2} \end{bmatrix} \begin{Bmatrix} 0 - (1.15) \\ 0 - (-0.06) \end{Bmatrix} 10^{-3} = +12.54 \text{ kN} \quad (2.75)$$

$$F_{13}'' = \frac{2 \times 10^4 (2)}{1.0} \cdot \begin{bmatrix} -1 & 0 \end{bmatrix} \begin{Bmatrix} 0 - (1.15) \\ 0 - (-0.06) \end{Bmatrix} 10^{-3} = +23.0 \text{ kN} \quad (2.76)$$

$$F_{14}'' = \frac{2 \times 10^4 (\sqrt{2})}{1.0 \sqrt{2}} \cdot \begin{bmatrix} -\frac{1}{\sqrt{2}} & -\frac{1}{\sqrt{2}} \end{bmatrix} \begin{Bmatrix} 0 - (1.15) \\ 0 - (-0.06) \end{Bmatrix} 10^{-3} = +15.4 \text{ kN} \quad (2.77)$$

Final

The final member forces are the superposition of Stage I and Stage II forces:

$$F_{12} = F_{12}^I + F_{12}^{II} = 0 + 12.54 = 12.54 \text{ kN} \quad (2.78)$$

$$F_{13} = F_{13}^I + F_{13}^{II} = -40 + 23.0 = -17.0 \text{ kN} \quad (2.79)$$

$$F_{14} = F_{14}^I + F_{14}^{II} = 0 + 15.4 = 15.4 \text{ kN} \quad (2.80)$$

Thus the final result is:

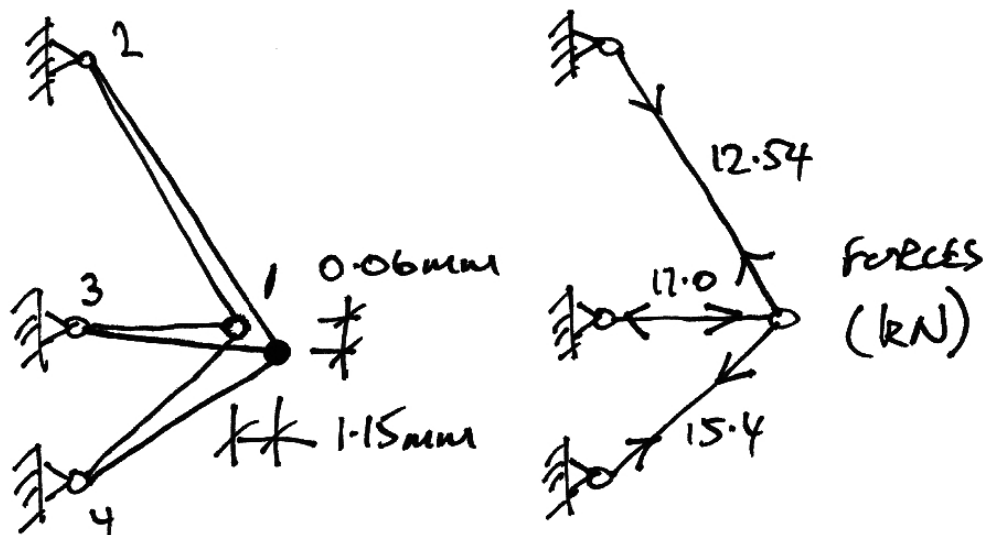

2.9 Example 6 – Truss with Loads & Self Strains

Problem

Analyse the same truss as Example 5, allowing for the following additional load sources:

- 80 kN acting horizontally to the left at node 1;
- 100 kN acting vertically downwards at node 1;
- Member 14 is $5\sqrt{2}$ mm too short upon arrival on site.

All as shown below:

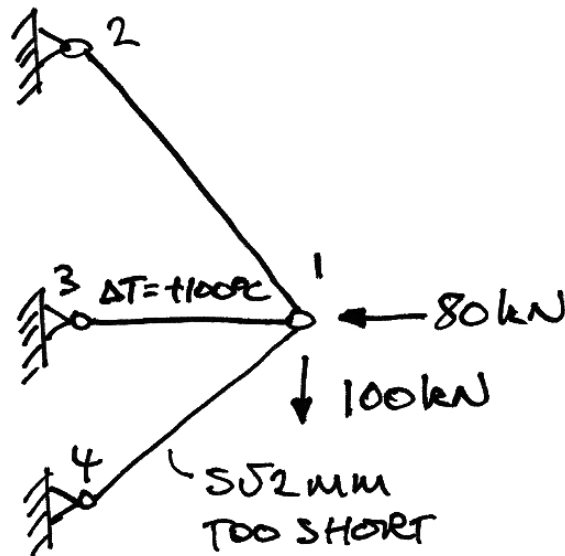

Solution

Again we will separate the actions into Stage I and Stage II scenarios.

Stage I

Displacements are suppressed and as a result the only sources of forces are self-straining forces:

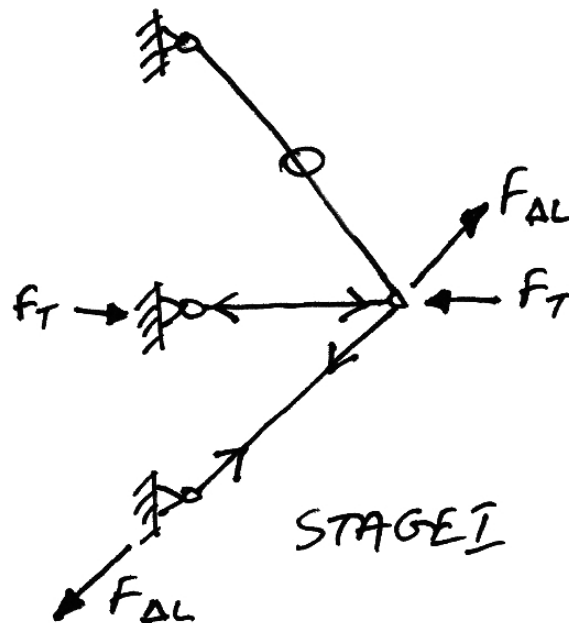

The forces and displacements for Stage I are thus:

$$F_T = 40 \text{ kN as before,}$$

$$F_{\Delta L} = EA \frac{\Delta L}{L} = \sqrt{2} (2 \times 10^4) \frac{5\sqrt{2} \times 10^{-3}}{\sqrt{2}} = 100\sqrt{2} \text{ kN} \quad (2.81)$$

$$\delta_{1x} = 0; \quad \delta_{1y} = 0 \quad (2.82)$$

$$F'_{12} = 0; \quad F'_{13} = -40; \quad F'_{14} = 100\sqrt{2} \quad (2.83)$$

Stage II

In this stage displacements are allowed and the forces in the self-strained members are now applied to the joints, in addition to any external loads. Thus we have:

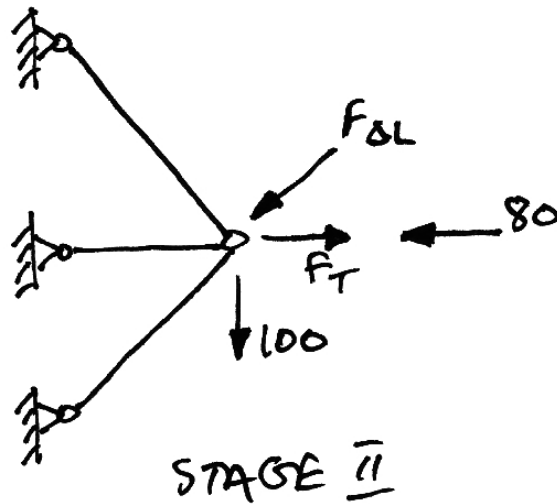

Clearly we need to resolve the forces at node 1 into net vertical and horizontal forces:

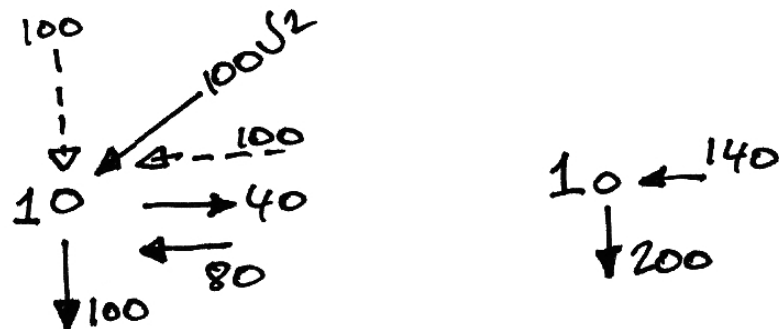

Since the members have not changed from Example 5, we can use the same stiffness matrix. Therefore we have :

$$\begin{Bmatrix} -140 \\ -200 \end{Bmatrix} = \frac{2 \times 10^4}{4} \begin{bmatrix} 7 & 2 - \sqrt{3} \\ 2 - \sqrt{3} & 5 \end{bmatrix} \begin{Bmatrix} \delta_{1x} \\ \delta_{1y} \end{Bmatrix} \quad (2.84)$$

Solve this:

$$\begin{aligned} \begin{Bmatrix} \delta_{1x} \\ \delta_{1y} \end{Bmatrix} &= \frac{4}{2 \times 10^4} \frac{1}{\left[7.5 - (2 - \sqrt{3})^2\right]} \begin{bmatrix} 5 & \sqrt{3} - 2 \\ \sqrt{3} - 2 & 7 \end{bmatrix} \begin{Bmatrix} -140 \\ -200 \end{Bmatrix} \\ &= 10^{-3} \begin{Bmatrix} -3.7 \\ -7.8 \end{Bmatrix} \text{ m} \end{aligned} \quad (2.85)$$

Using equation (2.21) we can find the member forces for Stage II:

$$F_{12}'' = \frac{2 \times 10^4}{2.0} \cdot \begin{bmatrix} -\frac{1}{2} & \frac{\sqrt{3}}{2} \\ \frac{1}{2} & \frac{\sqrt{3}}{2} \end{bmatrix} \begin{Bmatrix} 0 - (-3.7) \\ 0 - (-7.8) \end{Bmatrix} 10^{-3} = +98.1 \text{ kN} \quad (2.86)$$

$$F_{13}'' = \frac{2 \times 10^4 (2)}{1.0} \cdot \begin{bmatrix} -1 & 0 \\ 0 & 0 \end{bmatrix} \begin{Bmatrix} 0 - (-3.7) \\ 0 - (-7.8) \end{Bmatrix} 10^{-3} = -74.0 \text{ kN} \quad (2.87)$$

$$F_{14}'' = \frac{2 \times 10^4 (\sqrt{2})}{1.0 \sqrt{2}} \cdot \begin{bmatrix} -\frac{1}{\sqrt{2}} & -\frac{1}{\sqrt{2}} \\ \frac{1}{\sqrt{2}} & -\frac{1}{\sqrt{2}} \end{bmatrix} \begin{Bmatrix} 0 - (-3.7) \\ 0 - (-7.8) \end{Bmatrix} 10^{-3} = -162.6 \text{ kN} \quad (2.88)$$

Final

As before, the final member forces are the Stage I and Stage II forces:

$$F_{12} = F'_{12} + F''_{12} = 0 + 98.1 = 98.1 \text{ kN} \quad (2.89)$$

$$F_{13} = F'_{13} + F''_{13} = -40 - 74.0 = -114.0 \text{ kN} \quad (2.90)$$

$$F_{14} = F'_{14} + F''_{14} = 100\sqrt{2} - 162.6 = -21.6 \text{ kN} \quad (2.91)$$

Thus the final result is:

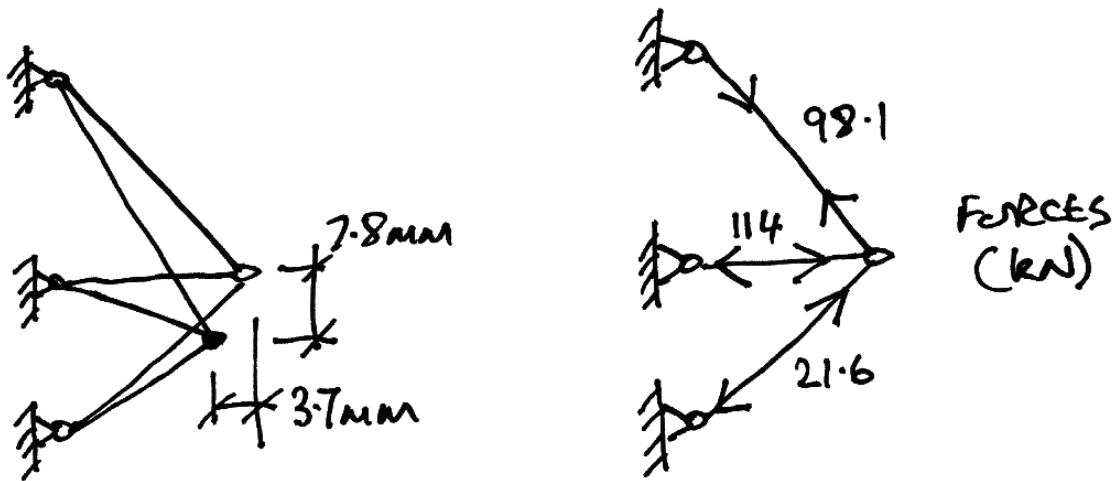

2.10 Problems

1. Determine the displacements of joint 1 and the member forces for the following truss. Take $EA = 2 \times 10^4$ kN.

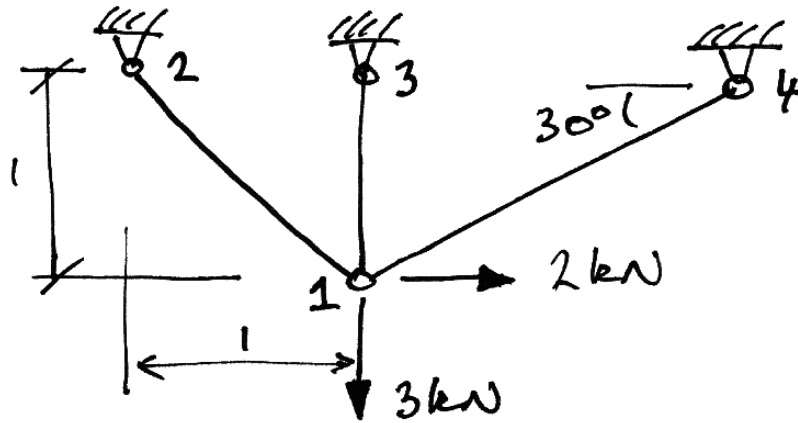

2. Determine the displacements of joint 1 and the member forces for the following truss. Take $EA = 2 \times 10^4$ kN, the area of both members is $A\sqrt{2}$.

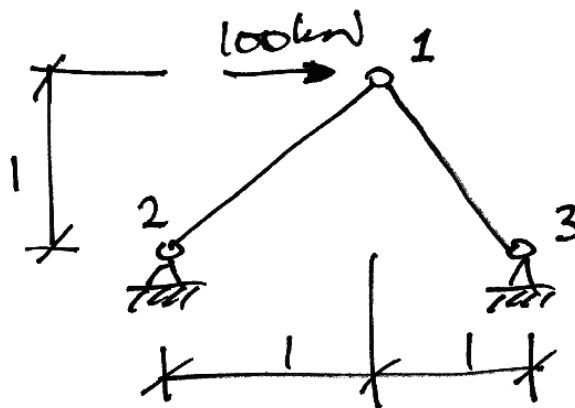

Ans. $\delta_{1x} = +5$ mm, $\delta_{1y} = 0$

3. Using any pertinent results from Problem 3, determine the area of member 14 such that the horizontal displacement of node 1 is half what it was prior to the installation of member 14. Determine also the force in member 14. Take $EA = 2 \times 10^4$ kN,

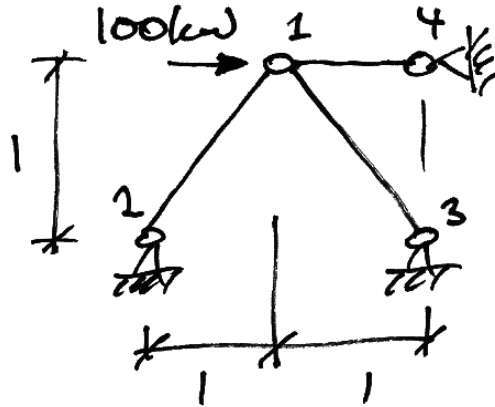

Ans. $A_{14} = A$, $F_{14} = -50$ kN

3. Beams

3.1 Beam Element Stiffness Matrix

To derive the beam element stiffness matrix, we recall some results obtained previously, summarized here:

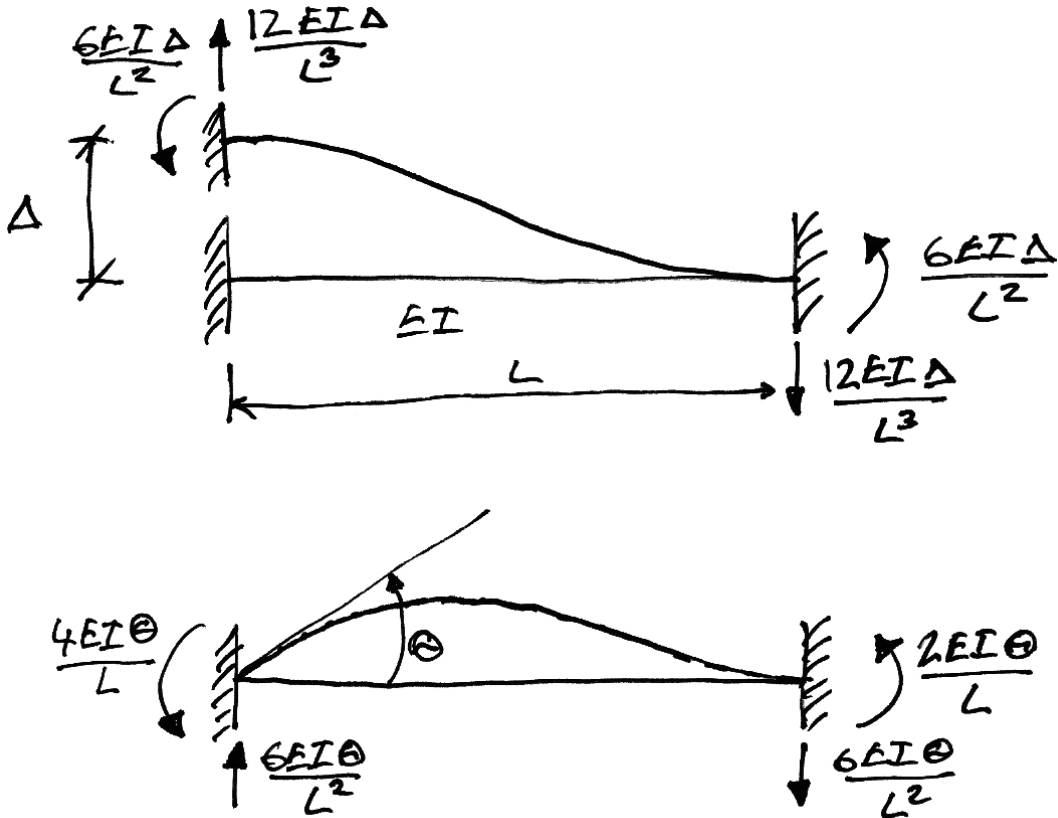

Next we must adopt strict local element sign convention and node identification:



Anti-clockwise moments and rotations (i.e. from the x -axis to the y -axis) are positive and upwards forces are positive.

Thus for a vertical displacement of Δ at node i , now labelled δ_{iy} , we have the following ‘force’ vector:

$$\begin{Bmatrix} F_{iy} \\ M_i \\ F_{jy} \\ M_j \end{Bmatrix} = \begin{Bmatrix} \frac{12EI}{L^3} \\ \frac{6EI}{L^2} \\ -\frac{12EI}{L^3} \\ \frac{6EI}{L^2} \end{Bmatrix} \delta_{iy} \quad (3.1)$$

Similarly, applying the same deflection, but at node j , δ_{jy} , gives:

$$\begin{Bmatrix} F_{iy} \\ M_i \\ F_{jy} \\ M_j \end{Bmatrix} = \begin{Bmatrix} -\frac{12EI}{L^3} \\ \frac{6EI}{L^2} \\ \frac{12EI}{L^3} \\ -\frac{6EI}{L^2} \end{Bmatrix} \delta_{jy} \quad (3.2)$$

Next, applying a rotation to node i , θ_i , gives:

$$\begin{Bmatrix} F_{iy} \\ M_i \\ F_{jy} \\ M_j \end{Bmatrix} = \begin{Bmatrix} \frac{6EI}{L^2} \\ \frac{4EI}{L} \\ -\frac{6EI}{L^2} \\ \frac{2EI}{L} \end{Bmatrix} \theta_i \quad (3.3)$$

And a rotation to node j , θ_j , gives:

$$\begin{Bmatrix} F_{iy} \\ M_i \\ F_{jy} \\ M_j \end{Bmatrix} = \begin{Bmatrix} \frac{6EI}{L^2} \\ \frac{2EI}{L} \\ \frac{6EI}{L^2} \\ \frac{4EI}{L} \end{Bmatrix} \theta_j \quad (3.4)$$

Since all of these displacement can happen together, using superposition we thus have the total force vector as:

$$\begin{Bmatrix} F_{iy} \\ M_i \\ F_{jy} \\ M_j \end{Bmatrix} = \begin{Bmatrix} \frac{12EI}{L^3} \\ \frac{6EI}{L^2} \\ -\frac{12EI}{L^3} \\ \frac{6EI}{L^2} \end{Bmatrix} \delta_{iy} + \begin{Bmatrix} \frac{6EI}{L^2} \\ \frac{4EI}{L} \\ -\frac{6EI}{L^2} \\ \frac{2EI}{L} \end{Bmatrix} \theta_i + \begin{Bmatrix} -\frac{12EI}{L^3} \\ \frac{6EI}{L^2} \\ \frac{12EI}{L^3} \\ -\frac{6EI}{L^2} \end{Bmatrix} \delta_{jy} + \begin{Bmatrix} \frac{6EI}{L^2} \\ \frac{2EI}{L} \\ \frac{6EI}{L^2} \\ \frac{4EI}{L} \end{Bmatrix} \theta_j \quad (3.5)$$

Writing this in matrix and vector form, we have:

$$\begin{Bmatrix} F_{iy} \\ M_i \\ F_{iy} \\ M_j \end{Bmatrix} = \begin{bmatrix} \frac{12EI}{L^3} & \frac{6EI}{L^2} & -\frac{12EI}{L^3} & \frac{6EI}{L^2} \\ \frac{6EI}{L^2} & \frac{4EI}{L} & -\frac{6EI}{L^2} & \frac{2EI}{L} \\ \frac{12EI}{L^3} & \frac{6EI}{L^2} & \frac{12EI}{L^3} & \frac{6EI}{L^2} \\ \frac{6EI}{L^2} & \frac{2EI}{L} & -\frac{6EI}{L^2} & \frac{4EI}{L} \end{bmatrix} \begin{Bmatrix} \delta_{iy} \\ \theta_i \\ \delta_{iy} \\ \theta_j \end{Bmatrix} \quad (3.6)$$

This is in the typical form:

$$\{\mathbf{F}^e\} = [\mathbf{k}]\{\mathbf{u}^e\} \quad (3.7)$$

And thus the beam element stiffness matrix is given by:

$$[\mathbf{k}] = \begin{bmatrix} \frac{12EI}{L^3} & \frac{6EI}{L^2} & -\frac{12EI}{L^3} & \frac{6EI}{L^2} \\ \frac{6EI}{L^2} & \frac{4EI}{L} & -\frac{6EI}{L^2} & \frac{2EI}{L} \\ \frac{12EI}{L^3} & \frac{6EI}{L^2} & \frac{12EI}{L^3} & \frac{6EI}{L^2} \\ \frac{6EI}{L^2} & \frac{2EI}{L} & -\frac{6EI}{L^2} & \frac{4EI}{L} \end{bmatrix} \quad (3.8)$$

Next we note a special case where the vertical displacements of the beam nodes are prevented and only rotations of the beam ends is allowed. In this case, all terms relating to the translation DOFs are removed giving us the reduced stiffness matrix for a beam on rigid vertical supports:

$$[\mathbf{k}] = \begin{bmatrix} \frac{4EI}{L} & \frac{2EI}{L} \\ \frac{2EI}{L} & \frac{4EI}{L} \end{bmatrix} \quad (3.9)$$

As we did for trusses, we will often write these equations in terms of nodal submatrices as:

$$\begin{Bmatrix} \mathbf{F}_i \\ \mathbf{F}_j \end{Bmatrix} = \begin{bmatrix} \mathbf{k11} & \mathbf{k12} \\ \mathbf{k21} & \mathbf{k22} \end{bmatrix} \begin{Bmatrix} \delta_i \\ \delta_j \end{Bmatrix} \quad (3.10)$$

3.2 Beam Element Loading

Applied Loads

Beam loads are different to truss loads since they can be located anywhere along the element, not only at the nodes – termed intermodal loading. Beams can also have loads applied to the nodes – nodal loading. We deal with these two kinds of loads as follows:

- Nodal loads: apply the load to the joint as usual;
- Inter-nodal loads: apply the equivalent concentrated loads to the joints (these are just fixed end moment reactions to the load, with the direction reversed).

If a member's nodes are locked against rotation, the member end forces due to inter-nodal loading will just be the fixed end moment and force reaction vector we are familiar with $\{\mathbf{F}_F\}$. If a member also displaces, the total member end forces are:

$$\{\mathbf{F}\}_{Tot} = \{\mathbf{F}_F\} + [\mathbf{k}]\{\boldsymbol{\delta}\} \quad (3.11)$$

Thus the general stiffness equation becomes:

$$\{\mathbf{F}\} = [\mathbf{K}]\{\boldsymbol{\delta}\} \quad (3.12)$$

Where $\{\mathbf{F}\}$ is now the vector of net nodal loads:

$$\text{Net Nodal Load} = \text{Nodal Load} - \sum \text{Fixed End Reactions} \quad (3.13)$$

Lastly, we must note that inter-nodal loads on adjacent members will result in multiple loads on a node. Thus we must take the algebraic sum of the forces/moments on each node in our analysis, bearing in mind the sign convention.

As an example, the equivalent nodal loads for a UDL applied to a beam element are:

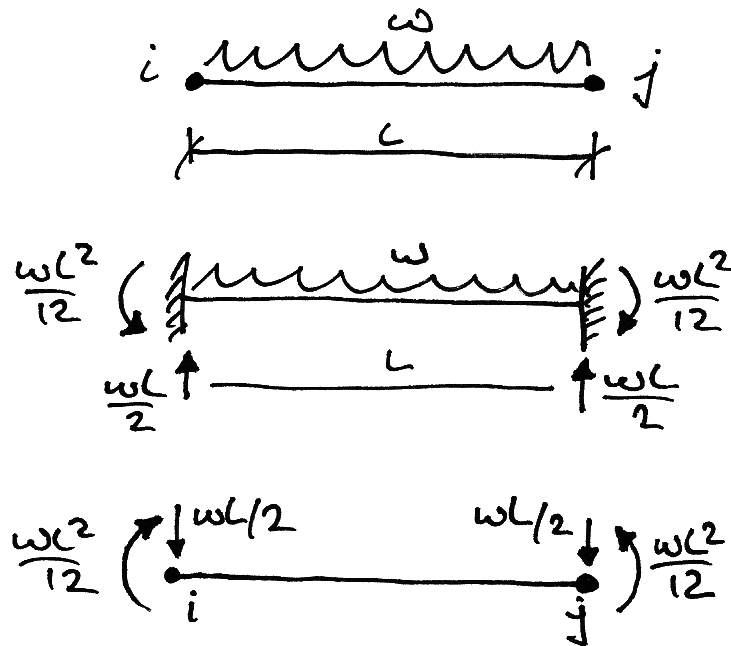

Member End Forces

After the deformations of the beam are known, we can use the element stiffness matrices to recover the end forces/moments on each element due to both deformations and the inter-nodal loading directly from equation (3.11).

3.3 Example 7 – Simple Two-Span Beam

Problem

For the following beam, find the rotations of joints 2 and 3 and the bending moment diagram. Take $EI = 6 \times 10^3 \text{ kNm}^2$.

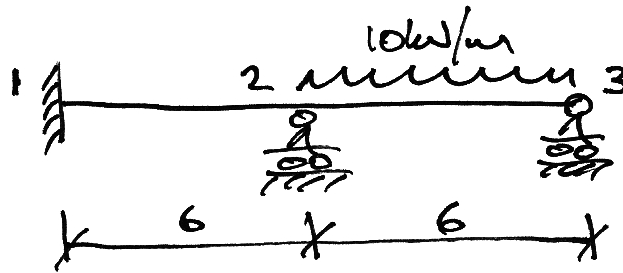

Solution

First we write the general equation in terms of nodal sub-matrices:

$$\begin{Bmatrix} \mathbf{F}_1 \\ \mathbf{F}_2 \\ \mathbf{F}_3 \end{Bmatrix} = \begin{bmatrix} \mathbf{K}_{11} & \mathbf{K}_{12} & \mathbf{K}_{13} \\ \mathbf{K}_{21} & \mathbf{K}_{22} & \mathbf{K}_{23} \\ \mathbf{K}_{31} & \mathbf{K}_{32} & \mathbf{K}_{33} \end{bmatrix} \begin{Bmatrix} \delta_1 \\ \delta_2 \\ \delta_3 \end{Bmatrix} \quad (3.14)$$

Next we note that the only possible displacements are the rotations of joints 2 and 3.

Thus we can restrict the equation by eliminating joint 1 as follows:

$$\begin{Bmatrix} \mathbf{F}_2 \\ \mathbf{F}_3 \end{Bmatrix} = \begin{bmatrix} \mathbf{K}_{22} & \mathbf{K}_{23} \\ \mathbf{K}_{32} & \mathbf{K}_{33} \end{bmatrix} \begin{Bmatrix} \delta_2 \\ \delta_3 \end{Bmatrix} \quad (3.15)$$

To give:

$$\begin{Bmatrix} \mathbf{F}_2 \\ \mathbf{F}_3 \end{Bmatrix} = \begin{bmatrix} \mathbf{K}_{22} & \mathbf{K}_{23} \\ \mathbf{K}_{32} & \mathbf{K}_{33} \end{bmatrix} \begin{Bmatrix} \boldsymbol{\delta}_2 \\ \boldsymbol{\delta}_3 \end{Bmatrix} \quad (3.16)$$

Since this beam is on rigid vertical supports, we can use the beam stiffness matrix given by equation (3.9). Thus we are left with two equations:

$$\begin{Bmatrix} M_2 \\ M_3 \end{Bmatrix} = \begin{bmatrix} k_{22} & k_{23} \\ k_{23} & k_{33} \end{bmatrix} \begin{Bmatrix} \theta_2 \\ \theta_3 \end{Bmatrix} \quad (3.17)$$

The member contributions to each of these terms are:

- k_{22} = Term 22 of Member 12 + Term 11 of Member 23;
- k_{23} = Term 12 of Member 23;
- k_{32} = Term 21 of Member 23;
- k_{33} = Term 22 of Member 23

Thus, for Member 12 we have:

$$[\mathbf{k}]_{12} = \begin{bmatrix} \frac{4EI}{L} & \frac{2EI}{L} \\ \frac{2EI}{L} & \frac{4EI}{L} \end{bmatrix} = 10^3 \begin{bmatrix} \frac{4(6)}{6} & \frac{2(6)}{6} \\ \frac{2(6)}{6} & \frac{4(6)}{6} \end{bmatrix} = 10^3 \begin{bmatrix} 4 & 2 \\ 2 & 4 \end{bmatrix} \quad (3.18)$$

And for Member 23:

$$[\mathbf{k}]_{23} = 10^3 \begin{bmatrix} \frac{4(6)}{6} & \frac{2(6)}{6} \\ \frac{2(6)}{6} & \frac{4(6)}{6} \end{bmatrix} = 10^3 \begin{bmatrix} 4 & 2 \\ 2 & 4 \end{bmatrix} \quad (3.19)$$

Thus the global stiffness equation is:

$$\begin{Bmatrix} M_2 \\ M_3 \end{Bmatrix} = 10^3 \begin{bmatrix} 8 & 2 \\ 2 & 4 \end{bmatrix} \begin{Bmatrix} \theta_2 \\ \theta_3 \end{Bmatrix} \quad (3.20)$$

To find the moments to apply to the nodes, we determine the fixed-end moments caused by the loads on each members. Only Member 23 has load, and its fixed end moments are:

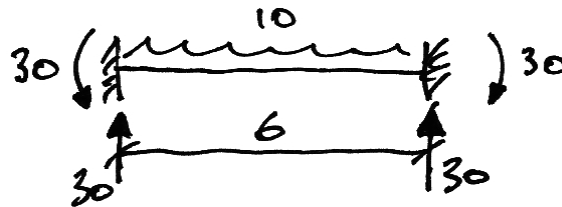

Our sign convention is anti-clockwise positive. Thus the moments to apply to the joints become (refer to equation (3.13)):

$$-\begin{Bmatrix} 30 \\ -30 \end{Bmatrix} = 10^3 \begin{bmatrix} 8 & 2 \\ 2 & 4 \end{bmatrix} \begin{Bmatrix} \theta_2 \\ \theta_3 \end{Bmatrix} \quad (3.21)$$

Solving the equation:

$$\begin{Bmatrix} \theta_2 \\ \theta_3 \end{Bmatrix} = \frac{1}{10^3} \frac{1}{(8 \cdot 4 - 2 \cdot 2)} \begin{bmatrix} 4 & -2 \\ -2 & 8 \end{bmatrix} \begin{Bmatrix} -30 \\ 30 \end{Bmatrix} = 10^{-3} \begin{Bmatrix} -90/14 \\ 150/14 \end{Bmatrix} \text{ rads} \quad (3.22)$$

Since we know that anti-clockwise is positive, we can draw the displaced shape (in mrad):

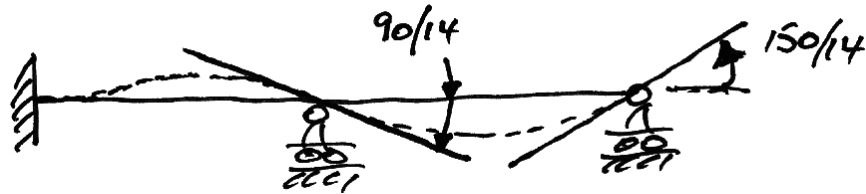

Using the member stiffness matrices we can recover the bending moments at the end of each member, now that the rotations are known, from equation (3.11):

$$\begin{Bmatrix} M_1 \\ M_2 \end{Bmatrix} = \begin{Bmatrix} 0 \\ 0 \end{Bmatrix} + 10^3 \begin{bmatrix} 4 & 2 \\ 2 & 4 \end{bmatrix} 10^{-3} \begin{Bmatrix} 0 \\ -90/14 \end{Bmatrix} = \begin{Bmatrix} -12.9 \\ -25.7 \end{Bmatrix} \text{ kNm} \quad (3.23)$$

$$\begin{Bmatrix} M_2 \\ M_3 \end{Bmatrix} = \begin{Bmatrix} 30 \\ -30 \end{Bmatrix} + 10^3 \begin{bmatrix} 4 & 2 \\ 2 & 4 \end{bmatrix} 10^{-3} \begin{Bmatrix} -90/14 \\ 150/14 \end{Bmatrix} = \begin{Bmatrix} +25.7 \\ 0 \end{Bmatrix} \text{ kNm} \quad (3.24)$$

Thus the final BMD can be drawn as:

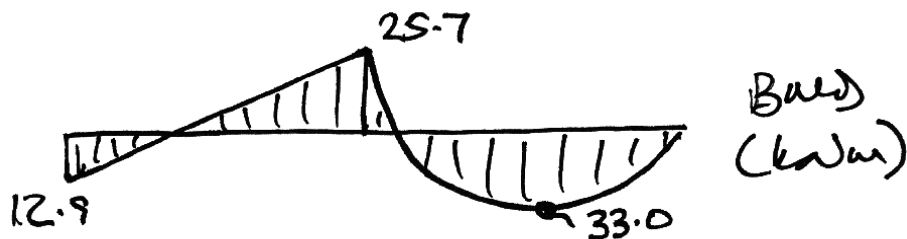

3.4 Example 8 – Non-Prismatic Beam

Problem

For the following beam, find the vertical deflection of joint 2 and the bending moment diagram. Take $EI = 12 \times 10^3 \text{ kNm}^2$.

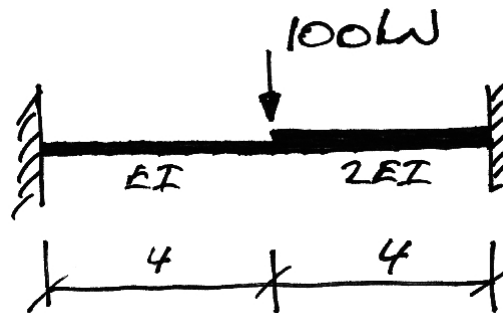

Solution

First we write the general equation in terms of nodal sub-matrices:

$$\begin{Bmatrix} \mathbf{F}_1 \\ \mathbf{F}_2 \\ \mathbf{F}_3 \end{Bmatrix} = \begin{bmatrix} \mathbf{K}_{11} & \mathbf{K}_{12} & \mathbf{K}_{13} \\ \mathbf{K}_{21} & \mathbf{K}_{22} & \mathbf{K}_{23} \\ \mathbf{K}_{31} & \mathbf{K}_{32} & \mathbf{K}_{33} \end{bmatrix} \begin{Bmatrix} \delta_1 \\ \delta_2 \\ \delta_3 \end{Bmatrix} \quad (3.25)$$

Next we note that the only possible displacements are those of joint 2. Thus we can restrict the equation to:

$$\{\mathbf{F}_2\} = [\mathbf{K}_{22}]\{\delta_2\} \quad (3.26)$$

The member contributions to \mathbf{K}_{22} are:

- Sub-matrix **k22** of member 12;
- Sub-matrix **k11** of member 23.

That is:

$$[\mathbf{K}_{22}] = [\mathbf{k}22_{12}] + [\mathbf{k}11_{23}] \quad (3.27)$$

For member 12, we have, from equation (3.8):

$$\mathbf{k}22_{12} = \begin{bmatrix} \frac{12EI}{L^3} & -\frac{6EI}{L^2} \\ -\frac{6EI}{L^2} & \frac{4EI}{L} \end{bmatrix} = 10^3 \begin{bmatrix} \frac{12 \cdot 12}{4^3} & -\frac{6 \cdot 12}{4^2} \\ -\frac{6 \cdot 12}{4^2} & \frac{4 \cdot 12}{4} \end{bmatrix} = 10^3 \begin{bmatrix} 2.25 & -4.5 \\ -4.5 & 12 \end{bmatrix} \quad (3.28)$$

And for member 23:

$$\mathbf{k}11_{23} = \begin{bmatrix} \frac{12EI}{L^3} & \frac{6EI}{L^2} \\ \frac{6EI}{L^2} & \frac{4EI}{L} \end{bmatrix} = 10^3 \begin{bmatrix} \frac{12 \cdot 24}{4^3} & \frac{6 \cdot 24}{4^2} \\ \frac{6 \cdot 24}{4^2} & \frac{4 \cdot 24}{4} \end{bmatrix} = 10^3 \begin{bmatrix} 4.5 & 9 \\ 9 & 24 \end{bmatrix} \quad (3.29)$$

Since the load is a directly applied nodal load we can now write equation (3.26), using equations (3.27), (3.28), and (3.29), as:

$$\begin{Bmatrix} F_{2y} \\ M_2 \end{Bmatrix} = \begin{Bmatrix} -100 \\ 0 \end{Bmatrix} = 10^3 \begin{bmatrix} 6.75 & 4.5 \\ 4.5 & 36 \end{bmatrix} \begin{Bmatrix} \delta_{2y} \\ \theta_2 \end{Bmatrix} \quad (3.30)$$

Solving:

$$\begin{Bmatrix} \delta_{2y} \\ \theta_2 \end{Bmatrix} = 10^{-3} \frac{1}{(6.75 \cdot 36 - 4.5 \cdot 4.5)} \begin{bmatrix} 36 & -4.5 \\ -4.5 & 6.75 \end{bmatrix} \begin{Bmatrix} -100 \\ 0 \end{Bmatrix} = 10^{-3} \begin{Bmatrix} -16.16 \\ 2.02 \end{Bmatrix} \quad (3.31)$$

Thus we have a downwards (negative) displacement of 16.2 mm and an anticlockwise rotation of 2.02 mrad at joint 2, as shown:

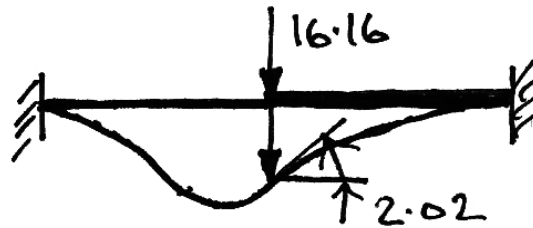

Next we recover the element end forces. For member 12, from equation (3.6) we have:

$$\begin{Bmatrix} F_{1y} \\ M_1 \\ F_{2y} \\ M_2 \end{Bmatrix} = 10^3 \begin{bmatrix} 2.25 & 4.5 & -2.25 & 4.5 \\ 4.5 & 12 & -4.5 & 6 \\ -2.25 & -4.5 & 2.25 & -4.5 \\ 4.5 & 6 & -4.5 & 12 \end{bmatrix} 10^{-3} \begin{Bmatrix} 0 \\ 0 \\ -16.16 \\ 2.02 \end{Bmatrix} = \begin{Bmatrix} 45.5 \\ 84.8 \\ -45.5 \\ 97.0 \end{Bmatrix} \quad (3.32)$$

And for member 23:

$$\begin{Bmatrix} F_{2y} \\ M_2 \\ F_{3y} \\ M_3 \end{Bmatrix} = 10^3 \begin{bmatrix} 4.5 & 9 & -4.5 & 9 \\ 9 & 24 & -9 & 12 \\ -4.5 & -9 & 4.5 & -9 \\ 9 & 12 & -9 & 24 \end{bmatrix} 10^{-3} \begin{Bmatrix} -16.16 \\ 2.02 \\ 0 \\ 0 \end{Bmatrix} = \begin{Bmatrix} -54.5 \\ -97.0 \\ 54.5 \\ -121.2 \end{Bmatrix} \quad (3.33)$$

Thus the member end forces are:

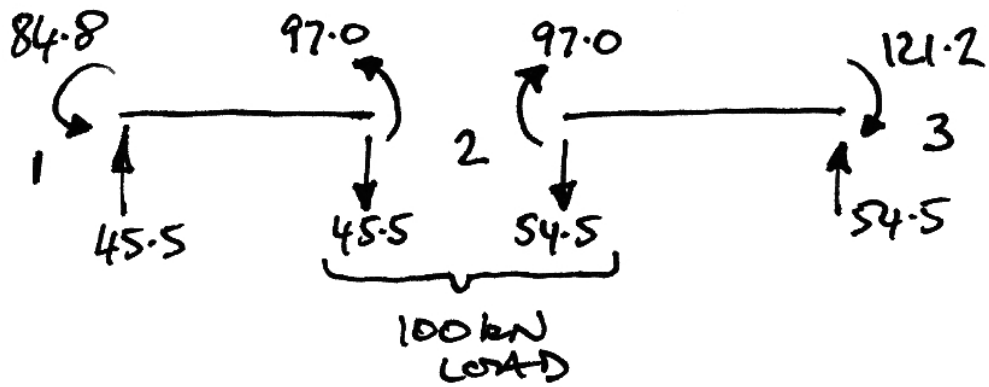

As can be seen, the load is split between the two members in a way that depends on their relative stiffness.

The total solution is thus:

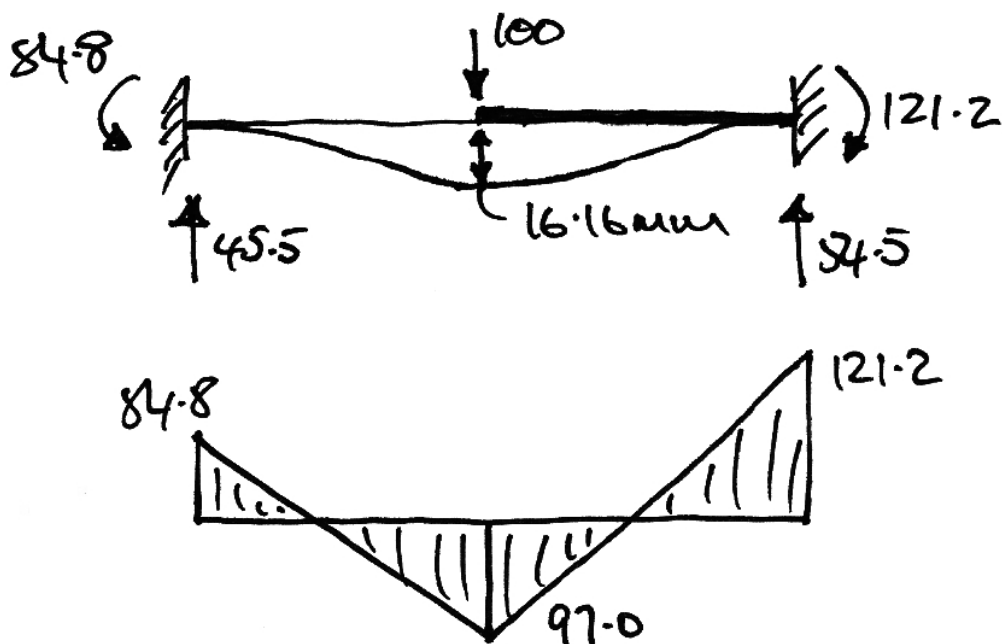

3.5 Problems

1. Determine the bending moment diagram and rotation of joint 2. Take $EI = 10 \times 10^3 \text{ kNm}^2$.

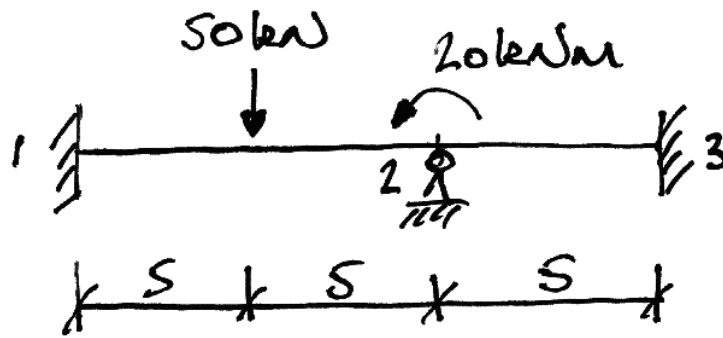

2. Determine the bending moment diagram and the vertical displacement under the 100 kN point load. Take $EI = 10 \times 10^3 \text{ kNm}^2$.

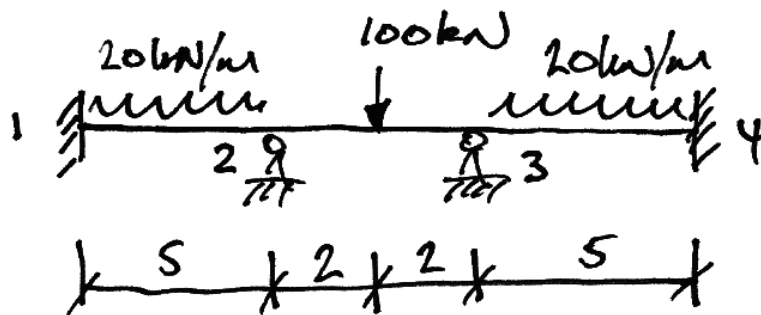

3. Determine the bending moment diagram and the rotations of joints 1 and 2. Take $EI = 10 \times 10^3 \text{ kNm}^2$.

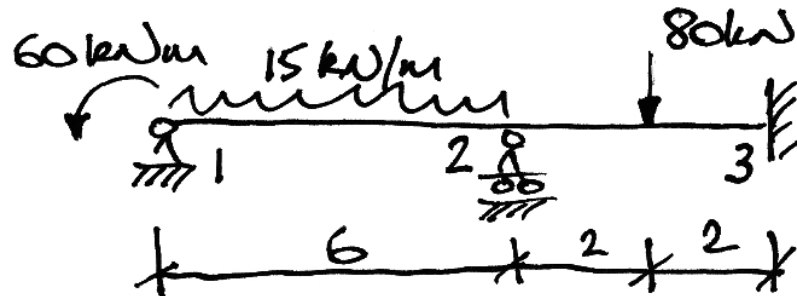

4. Plane Frames

4.1 Plane Frame Element Stiffness Matrix

A plane frame element is similar to a beam element except for some differences:

- The presence of axial forces;
- The member may be oriented at any angle in the global axis system;
- The inter-nodal loads may be applied in the local or global coordinates.

These points are illustrated in the following:

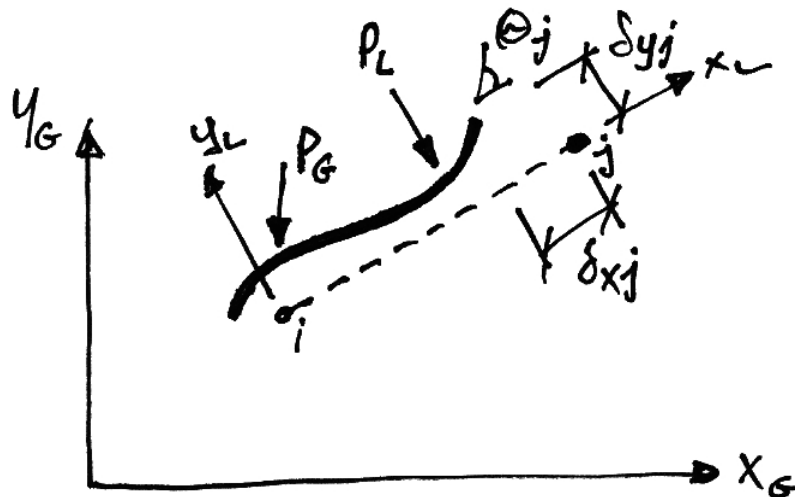

Lastly, an easy way to deal with inter-nodal point loads (P_G , P_L) is to introduce a node under the point load (splitting the member in two), then it is no longer inter-nodal and so no transformations or equivalent load analysis is required. The downside to this is that the number of equations increases (which is only really a problem for analysis by hand).

Axial Forces

To include axial forces, we can simply expand the beam element stiffness matrix to allow for the extra degree of freedom of x -displacement at each node in the member local coordinates. Thus expanding equation (3.8) to allow for the extra DOFs gives:

$$[\mathbf{k}] = \begin{bmatrix} X_{11} & 0 & 0 & X_{14} & 0 & 0 \\ 0 & \frac{12EI}{L^3} & \frac{6EI}{L^2} & 0 & -\frac{12EI}{L^3} & \frac{6EI}{L^2} \\ 0 & \frac{6EI}{L^2} & \frac{4EI}{L} & 0 & -\frac{6EI}{L^2} & \frac{2EI}{L} \\ \hline X_{41} & 0 & 0 & X_{44} & 0 & 0 \\ 0 & -\frac{12EI}{L^3} & -\frac{6EI}{L^2} & 0 & \frac{12EI}{L^3} & -\frac{6EI}{L^2} \\ 0 & \frac{6EI}{L^2} & \frac{2EI}{L} & 0 & -\frac{6EI}{L^2} & \frac{4EI}{L} \end{bmatrix} \quad (4.1)$$

However, these terms that account for axial force are simply those of a plane truss element in its local coordinate system:

$$[\mathbf{k}] = \frac{EA}{L} \begin{bmatrix} 1 & -1 \\ -1 & 1 \end{bmatrix} \quad (4.2)$$

Thus equation (4.1) becomes:

$$\mathbf{[k]} = \begin{bmatrix} \frac{EA}{L} & 0 & 0 & -\frac{EA}{L} & 0 & 0 \\ 0 & \frac{12EI}{L^3} & \frac{6EI}{L^2} & 0 & -\frac{12EI}{L^3} & \frac{6EI}{L^2} \\ 0 & \frac{6EI}{L^2} & \frac{4EI}{L} & 0 & -\frac{6EI}{L^2} & \frac{2EI}{L} \\ -\frac{EA}{L} & 0 & 0 & \frac{EA}{L} & 0 & 0 \\ 0 & -\frac{12EI}{L^3} & -\frac{6EI}{L^2} & 0 & \frac{12EI}{L^3} & -\frac{6EI}{L^2} \\ 0 & \frac{6EI}{L^2} & \frac{2EI}{L} & 0 & -\frac{6EI}{L^2} & \frac{4EI}{L} \end{bmatrix} \quad (4.3)$$

This is the stiffness matrix for a plane frame element in its local coordinate system and can also be written in terms of nodal sub-matrices as:

$$\mathbf{[k]} = \begin{bmatrix} \mathbf{k11} & \mathbf{k12} \\ \mathbf{k21} & \mathbf{k22} \end{bmatrix} \quad (4.4)$$

Where the nodal sub-matrices are as delineated in equation (4.3).

Note that if axial forces are neglected, we can just use the regular beam element stiffness matrix instead, though coordinate transformation may be required.

Transformation to Global Coordinates

Directly, from the Appendix, the plane frame element stiffness matrix in global coordinates is thus:

$$[\mathbf{K}^e] = [\mathbf{T}]^T [\mathbf{k}] [\mathbf{T}] \quad (4.5)$$

As a consequence, note that we do not need to perform the transformation when:

1. The member local axis and global axis system coincide;
2. The only unrestrained DOFs are rotations/moments.

In which, (again from the Appendix), the transformation matrix for a plane frame element is:

$$\mathbf{T} = \begin{bmatrix} \cos \alpha & \sin \alpha & 0 & | & 0 & 0 & 0 \\ -\sin \alpha & \cos \alpha & 0 & | & 0 & 0 & 0 \\ 0 & 0 & 1 & | & 0 & 0 & 0 \\ \hline 0 & 0 & 0 & | & \cos \alpha & \sin \alpha & 0 \\ 0 & 0 & 0 & | & -\sin \alpha & \cos \alpha & 0 \\ 0 & 0 & 0 & | & 0 & 0 & 1 \end{bmatrix} \quad (4.6)$$

Inter-nodal Loads

In plane frames, loads can be applied in the global axis system, or the local axis system. For example, if we consider a member representing a roof beam, we can have the following loads:

- Case 1: Gravity loads representing the weight of the roof itself;
- Case 2: Horizontal loads representing a horizontal wind;
- Case 3: Net pressure loads caused by outside wind and inside pressures.

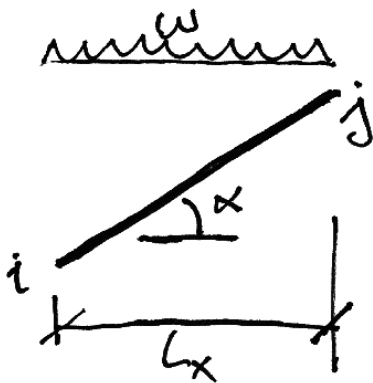

Case 1

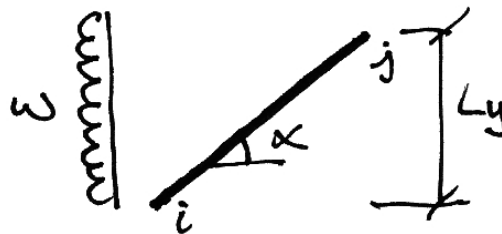

Case 2

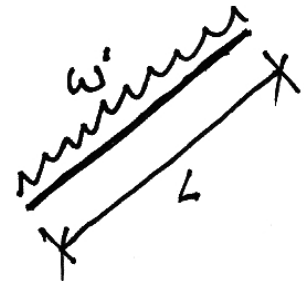

Case 3

Most structural analysis software will allow you to choose the axis system of your loads. However, in order to deal with these loads for simple hand analysis we must know how it works and so we consider each case separately.

In the following the member local axis system has a prime (e.g. x') and the global axis system does not (e.g. x).

Case 1: Vertically Applied Loads

In this case we can consider an equivalent beam which is the projection of the load onto a horizontal beam of length L_x :

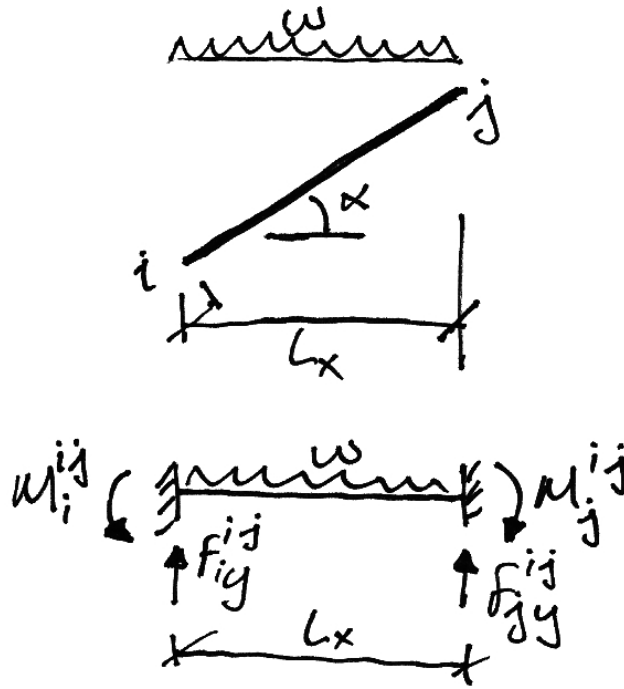

Since the resulting nodal forces and moments are in the global axis system no further work is required.

Case 2: Horizontally Applied Loads:

Similarly to vertically applied loads, we can consider the horizontal projection of load onto an equivalent member of length L_y .

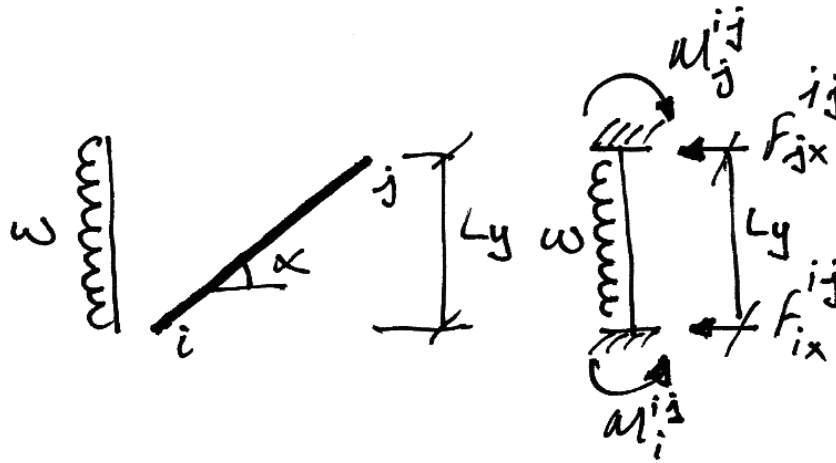

Again the resulting nodal loads are in the global axis system and do not require any modification.

Case 3: Loads Applied in Local Member Axis System

In this case there is no need for an equivalent beam and the fixed-fixed reactions are worked out as normal:

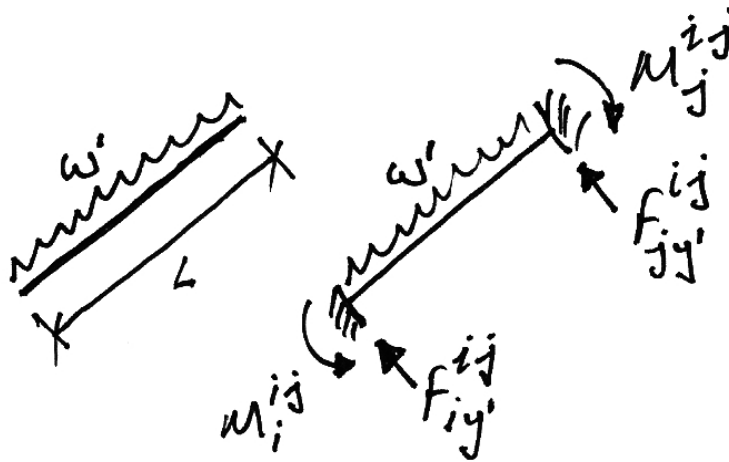

However, there is a complication here since the reactions are now not all in the global axis system. Thus the forces (not moments) must be transformed from the local axis to the global axis system. Thus there is a simple case:

If axial forces are neglected, only moments are relevant and so no transformations are required.

For generality though we can use the transformations given in the Appendix:

$$\{\mathbf{F}\} = [\mathbf{T}]^T \{\mathbf{F}'\} \tag{4.7}$$

Writing this out in full for clarity, we have:

$$\begin{Bmatrix} F_{ix}^{ij} \\ F_{iy}^{ij} \\ M_i^{ij} \\ F_{jx}^{ij} \\ F_{jy}^{ij} \\ M_j^{ij} \end{Bmatrix} = \begin{bmatrix} \cos \alpha & -\sin \alpha & 0 & 0 & 0 & 0 \\ \sin \alpha & \cos \alpha & 0 & 0 & 0 & 0 \\ 0 & 0 & 1 & 0 & 0 & 0 \\ \hline 0 & 0 & 0 & \cos \alpha & -\sin \alpha & 0 \\ 0 & 0 & 0 & \sin \alpha & \cos \alpha & 0 \\ 0 & 0 & 0 & 0 & 0 & 1 \end{bmatrix} \begin{Bmatrix} F_{ix'}^{ij} \\ F_{iy'}^{ij} \\ M_i^{ij} \\ F_{jx'}^{ij} \\ F_{jy'}^{ij} \\ M_j^{ij} \end{Bmatrix} \quad (4.8)$$

4.2 Example 9 – Simple Plane Frame

Problem

For the following frame, determine the rotation of the joints and the bending moment diagram. Neglect axial deformations. Take $EI = 1 \times 10^3 \text{ kNm}^2$.

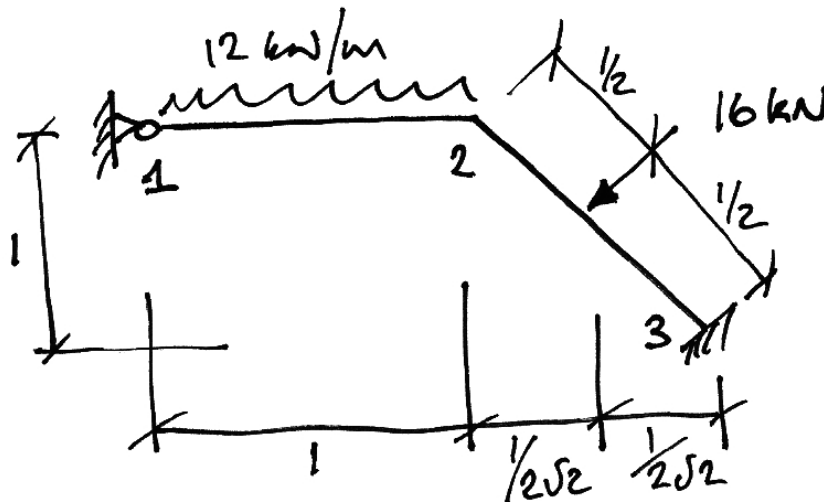

Solution

The fact that we can neglect axial deformation makes this problem much simpler. As a consequence, the only possible displacements are the rotations of joints 1 and 2. Since node 3 is fully restricted out, we have the following partially-restricted set of equations in terms of nodal sub-matrices:

$$\begin{Bmatrix} \mathbf{F}_1 \\ \mathbf{F}_2 \end{Bmatrix} = \begin{bmatrix} \mathbf{K}_{11} & \mathbf{K}_{12} \\ \mathbf{K}_{21} & \mathbf{K}_{22} \end{bmatrix} \begin{Bmatrix} \delta_1 \\ \delta_2 \end{Bmatrix} \quad (4.9)$$

If we expand this further, we will be able to restrict out all but the rotational DOFs:

$$\left\{ \begin{array}{c} \cdot \\ \cdot \\ \hline \sum M_1 \\ \cdot \\ \cdot \\ \hline \sum M_2 \end{array} \right\} = \left[\begin{array}{ccc|ccc} \cdot & \cdot & \cdot & \cdot & \cdot & \cdot \\ \cdot & \cdot & \cdot & \cdot & \cdot & \cdot \\ \cdot & \cdot & k_{33} & \cdot & \cdot & k_{36} \\ \hline \cdot & \cdot & \cdot & \cdot & \cdot & \cdot \\ \cdot & \cdot & \cdot & \cdot & \cdot & \cdot \\ \cdot & \cdot & k_{63} & \cdot & \cdot & k_{66} \end{array} \right] \left\{ \begin{array}{c} \cdot \\ \cdot \\ \theta_1 \\ \cdot \\ \cdot \\ \theta_2 \end{array} \right\} \quad (4.10)$$

The member contributions to each of these terms are:

- k_{33} = Term 33 of Member 12;
- k_{36} = Term 36 of Member 12;
- k_{63} = Term 63 of Member 12;
- k_{66} = Term 66 of Member 12 + Term 33 of Member 23.

- Member 12:

Looking at equation (4.3):

$$\text{Term 33} = \left(\frac{4EI}{L} \right)_{12} = \frac{4 \cdot 10^3}{1} = 4 \times 10^3 \quad (4.11)$$

$$\text{Term 36} = \left(\frac{2EI}{L} \right)_{12} = \frac{2 \cdot 10^3}{1} = 2 \times 10^3 \quad (4.12)$$

$$\text{Term 63} = \left(\frac{2EI}{L} \right)_{12} = \frac{2 \cdot 10^3}{1} = 2 \times 10^3 \quad (4.13)$$

$$\text{Term 66} = \left(\frac{4EI}{L} \right)_{12} = \frac{4 \cdot 10^3}{1} = 4 \times 10^3 \quad (4.14)$$

- Member 23:

Again, from equation (4.3):

$$\text{Term 33} = \left(\frac{4EI}{L} \right)_{23} = \frac{4 \cdot 10^3}{1} = 4 \times 10^3 \quad (4.15)$$

Thus the system equation becomes:

$$\begin{Bmatrix} \sum M_1 \\ \sum M_2 \end{Bmatrix} = 10^3 \begin{bmatrix} 4 & 2 \\ 2 & 8 \end{bmatrix} \begin{Bmatrix} \theta_1 \\ \theta_2 \end{Bmatrix} \quad (4.16)$$

Next we must find the net moments applied to each node. There are no directly applied nodal moment loads, so the ‘force’ vector is, from equation (3.13):

$$\{\mathbf{F}\} = -\{\mathbf{F}_F\} \quad (4.17)$$

- Member 12 Moments:

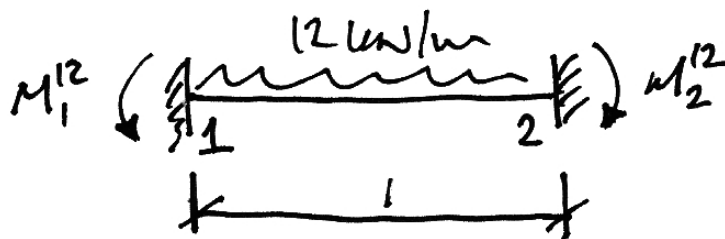

$$\begin{aligned} M_1^{12} &= \frac{wL^2}{12} = \frac{12 \cdot 1^2}{12} = +1 \text{ kNm} \\ M_2^{12} &= -\frac{wL^2}{12} = -\frac{12 \cdot 1^2}{12} = -1 \text{ kNm} \end{aligned} \quad (4.18)$$

- Member 23 Moments:

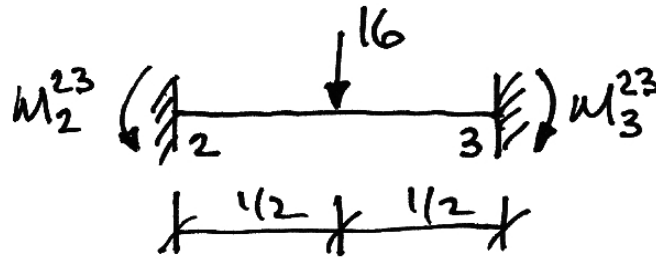

$$M_2^{23} = \frac{PL}{8} = \frac{16 \cdot 1}{8} = +2 \text{ kNm}$$

$$M_3^{23} = -\frac{PL}{8} = -\frac{16 \cdot 1}{8} = -2 \text{ kNm}$$
(4.19)

Thus the net nodal loads become:

$$\{\mathbf{F}\} = -\{\mathbf{F}_F\} = -\left\{ \begin{array}{c} \sum M_1 \\ \sum M_2 \end{array} \right\} = -\left\{ \begin{array}{c} +1 \\ -1 + 2 \end{array} \right\} = \left\{ \begin{array}{c} -1 \\ -2 \end{array} \right\} \text{ kNm}$$
(4.20)

And so equation (4.16) is thus:

$$\left\{ \begin{array}{c} -1 \\ -1 \end{array} \right\} = 10^3 \begin{bmatrix} 4 & 2 \\ 2 & 8 \end{bmatrix} \left\{ \begin{array}{c} \theta_1 \\ \theta_2 \end{array} \right\}$$
(4.21)

Which is solved to get:

$$\left\{ \begin{array}{c} \theta_1 \\ \theta_2 \end{array} \right\} = \frac{1}{10^3} \frac{1}{(4 \cdot 8 - 2 \cdot 2)} \begin{bmatrix} 8 & -2 \\ -2 & 4 \end{bmatrix} \left\{ \begin{array}{c} -1 \\ -1 \end{array} \right\} = \left\{ \begin{array}{c} -3/14 \\ -1/14 \end{array} \right\} \times 10^{-3} \text{ rads}$$
(4.22)

The negative results indicate both rotations are clockwise.

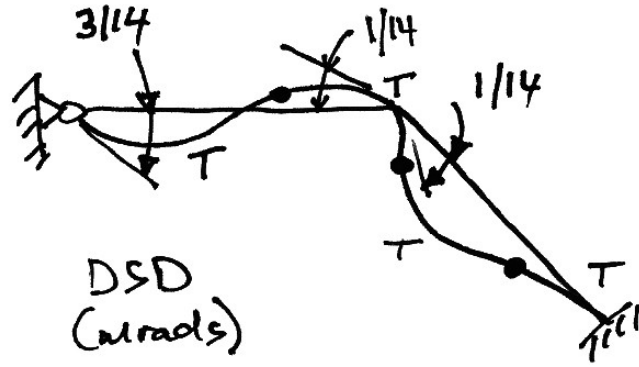

Lastly, we must find the member end forces. Since we only need to draw the bending moment diagram so we need only consider the terms of the member stiffness matrix relating to the moments/rotations (similar to equation (3.9)). Also, we must account for the equivalent nodal loads as per equation (3.11):

- Member 12:

$$\begin{Bmatrix} M_1^{12} \\ M_2^{12} \end{Bmatrix} = \begin{Bmatrix} +1 \\ -1 \end{Bmatrix} + 10^3 \begin{bmatrix} 4 & 2 \\ 2 & 4 \end{bmatrix} \begin{Bmatrix} -3/14 \\ -1/14 \end{Bmatrix} 10^{-3} = \begin{Bmatrix} 0 \\ -12/7 \end{Bmatrix} \text{ kNm} \quad (4.23)$$

- Member 23:

$$\begin{Bmatrix} M_2^{23} \\ M_3^{23} \end{Bmatrix} = \begin{Bmatrix} +2 \\ -2 \end{Bmatrix} + 10^3 \begin{bmatrix} 4 & 2 \\ 2 & 4 \end{bmatrix} \begin{Bmatrix} -1/14 \\ 0 \end{Bmatrix} 10^{-3} = \begin{Bmatrix} +12/7 \\ -17/7 \end{Bmatrix} \text{ kNm} \quad (4.24)$$

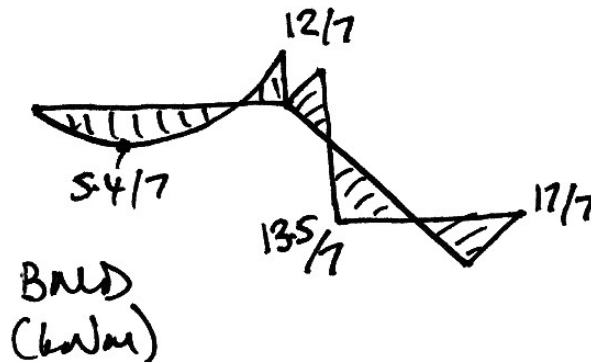

4.3 Example 10 –Plane Frame Using Symmetry

Problem

For the following frame, determine the rotation of the joints, the displacement under the 8 kN point load and the bending moment diagram. Neglect axial deformations. Take $EI = 1 \times 10^3 \text{ kNm}^2$.

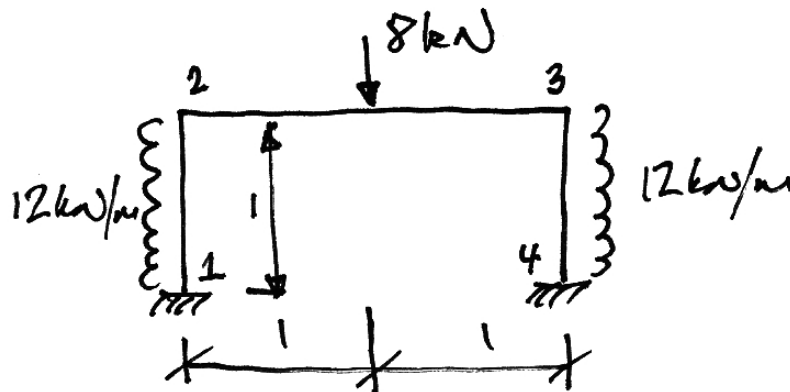

Solution

Again, the fact that we can neglect axial deformation makes this problem much simpler. Since the structure is symmetrical and it is symmetrically loaded, it will not sway. Further, because of this symmetry, we can adopt the following model for analysis:

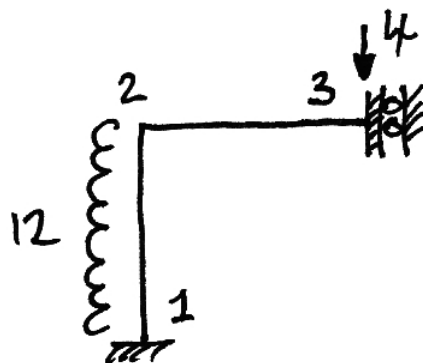

Notice two things from this model:

- we have renumber the joints – there is no need to retain the old numbering system;
- The remaining DOFs are θ_2 and δ_{3y} - we can restrict all other DOFs. Thus in terms of nodal sub-matrices we immediately have:

$$\begin{Bmatrix} \mathbf{F}_2 \\ \mathbf{F}_3 \end{Bmatrix} = \begin{bmatrix} \mathbf{K11} & \mathbf{K12} \\ \mathbf{K21} & \mathbf{K22} \end{bmatrix} \begin{Bmatrix} \delta_2 \\ \delta_3 \end{Bmatrix} \quad (4.25)$$

And expanding this further, we restrict out all other restrained DOFs:

$$\begin{Bmatrix} \cdot \\ \cdot \\ \sum M_2 \\ \cdot \\ \sum F_{3y} \\ \cdot \end{Bmatrix} = \begin{bmatrix} \cdot & \cdot & \cdot & \cdot & \cdot & \cdot \\ \cdot & \cdot & \cdot & \cdot & \cdot & \cdot \\ \cdot & \cdot & k_{66} & \cdot & k_{68} & \cdot \\ \cdot & \cdot & \cdot & \cdot & \cdot & \cdot \\ \cdot & \cdot & \cdot & \cdot & \cdot & \cdot \\ \cdot & \cdot & \cdot & \cdot & \cdot & \cdot \end{bmatrix} \begin{Bmatrix} \cdot \\ \cdot \\ \theta_2 \\ \cdot \\ \delta_{3y} \\ \cdot \end{Bmatrix} \quad (4.26)$$

The member contributions to each of these terms are:

- k_{66} = Term 66 of Member 12 + Term 33 of Member 23;
- k_{68} = Term 35 of Member 23;
- k_{86} = Term 53 of Member 23;
- k_{88} = Term 55 of Member 23.

Transformation of the member stiffness matrices is not required. Member 12 only has a rotational DOF and Member 23's local member coordinate system is parallel to the global axis coordinate system.

- Member 12:

From equation (4.3):

$$\text{Term 66} = \left(\frac{4EI}{L} \right)_{12} = \frac{4 \cdot 10^3}{1} = 4 \times 10^3 \quad (4.27)$$

- Member 23:

Again, from equation (4.3):

$$\text{Term 33} = \left(\frac{4EI}{L} \right)_{23} = \frac{4 \cdot 10^3}{1} = 4 \times 10^3 \quad (4.28)$$

$$\text{Term 35} = \left(-\frac{6EI}{L^2} \right)_{23} = -\frac{6 \cdot 10^3}{1^2} = -6 \times 10^3 \quad (4.29)$$

$$\text{Term 53} = \left(-\frac{6EI}{L^2} \right)_{23} = -\frac{6 \cdot 10^3}{1^2} = -6 \times 10^3 \quad (4.30)$$

$$\text{Term 55} = \left(\frac{12EI}{L^3} \right)_{23} = \frac{12 \cdot 10^3}{1^3} = 12 \times 10^3 \quad (4.31)$$

Thus the system equation becomes:

$$\begin{Bmatrix} \sum M_2 \\ \sum F_{3y} \end{Bmatrix} = 10^3 \begin{bmatrix} 8 & -6 \\ -6 & 12 \end{bmatrix} \begin{Bmatrix} \theta_2 \\ \delta_{3y} \end{Bmatrix} \quad (4.32)$$

The 4 kN point load is directly applied to node 3 so this causes no difficulty. The equivalent nodal loads for the UDL are:

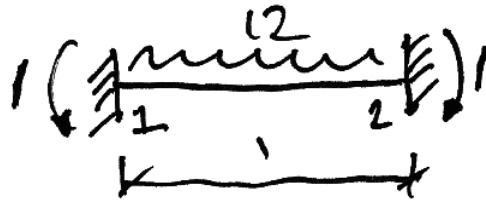

$$M_1^{12} = \frac{wL^2}{12} = \frac{12 \cdot 1^2}{12} = +1 \text{ kNm}$$

$$M_2^{12} = -\frac{wL^2}{12} = -\frac{12 \cdot 1^2}{12} = -1 \text{ kNm}$$
(4.33)

Notice that we do not need to find the vertical reaction forces as there is no sway of the frame and we are neglecting axial deformation.

The nodal load vector, from equation (3.13) is thus:

$$\{\sum \mathbf{F}\} = \{\mathbf{F}\} - \{\mathbf{F}_F\} = \begin{Bmatrix} 0 \\ -4 \end{Bmatrix} - \begin{Bmatrix} -1 \\ 0 \end{Bmatrix} = \begin{Bmatrix} +1 \\ -4 \end{Bmatrix}$$
(4.34)

And so equation (4.32) is thus:

$$\begin{Bmatrix} +1 \\ -4 \end{Bmatrix} = 10^3 \begin{bmatrix} 8 & -6 \\ -6 & 12 \end{bmatrix} \begin{Bmatrix} \theta_2 \\ \delta_{3y} \end{Bmatrix}$$
(4.35)

Which is solved to get:

$$\begin{Bmatrix} \theta_2 \\ \delta_{3y} \end{Bmatrix} = \frac{1}{10^3} \frac{1}{[8 \cdot 12 - (-6)(-6)]} \begin{bmatrix} 12 & 6 \\ 6 & 8 \end{bmatrix} \begin{Bmatrix} +1 \\ -4 \end{Bmatrix} = \begin{Bmatrix} -0.2 \\ -0.43 \end{Bmatrix} \times 10^{-3} \begin{matrix} \text{rads} \\ \text{m} \end{matrix}$$
(4.36)

The negative results indicate the rotation is clockwise and the displacement downwards, as may be expected:

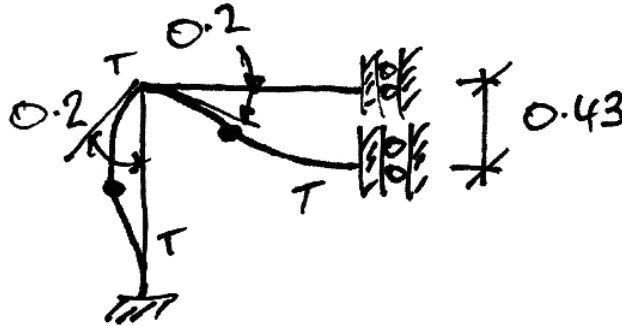

Lastly then we find the bending moments. For member 12 only the terms relating to bending moments are relevant.

- Member 12:

$$\begin{Bmatrix} M_1^{12} \\ M_2^{12} \end{Bmatrix} = \begin{Bmatrix} +1 \\ -1 \end{Bmatrix} + 10^3 \begin{bmatrix} 4 & 2 \\ 2 & 4 \end{bmatrix} \begin{Bmatrix} 0 \\ -0.2 \end{Bmatrix} 10^{-3} = \begin{Bmatrix} +0.6 \\ -1.8 \end{Bmatrix} \text{ kNm} \quad (4.37)$$

However, for member 23, the downwards deflection also causes moments and so the relevant DOFs are rotation of node i and vertical movement of node j (as calculated earlier). It is easier to see this if we write the member equation in full:

- Member 23:

$$\begin{Bmatrix} \cdot \\ \cdot \\ M_2^{23} \\ \cdot \\ \cdot \\ M_3^{23} \end{Bmatrix} = 10^3 \begin{bmatrix} \cdot & \cdot & \cdot & \cdot & \cdot & \cdot \\ \cdot & \cdot & \cdot & \cdot & \cdot & \cdot \\ \cdot & \cdot & 4 & \cdot & -6 & \cdot \\ \cdot & \cdot & \cdot & \cdot & \cdot & \cdot \\ \cdot & \cdot & \cdot & \cdot & \cdot & \cdot \\ \cdot & \cdot & 2 & \cdot & -6 & \cdot \end{bmatrix} \begin{Bmatrix} \cdot \\ \cdot \\ -0.2 \\ \cdot \\ -0.43 \\ \cdot \end{Bmatrix} \times 10^{-3} \quad (4.38)$$

Thus:

$$\begin{Bmatrix} M_2^{23} \\ M_3^{23} \end{Bmatrix} = \begin{Bmatrix} +1.8 \\ +2.2 \end{Bmatrix} \text{ kNm} \quad (4.39)$$

And so the BMD is:

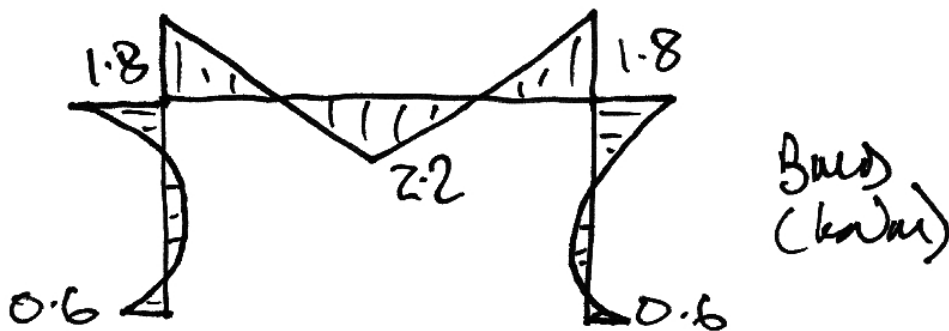

4.4 Problems

1. Determine the bending moment diagram and the rotation of joint 2. Take $EI = 10 \times 10^3 \text{ kNm}^2$ and neglect axial deformations.

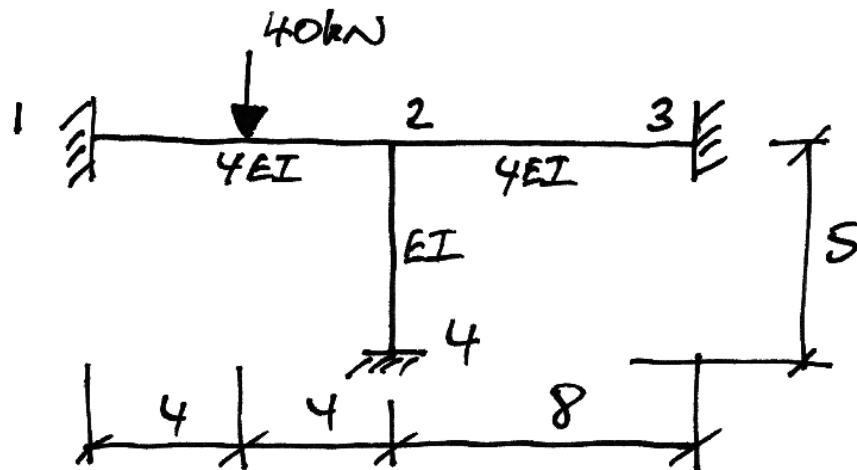

2. For the frame of Problem 1, determine the bending moment diagram and the rotation and vertical displacement of joint 2 if member 24 has $EA = 10 \times 10^3 \text{ kN}$. Neglect axial deformation in the other members.

3. Determine the bending moment diagram, the rotation of joint 2, and the vertical displacement under the 80 kN point load. Take $EI = 10 \times 10^3 \text{ kNm}^2$ and neglect axial deformations.

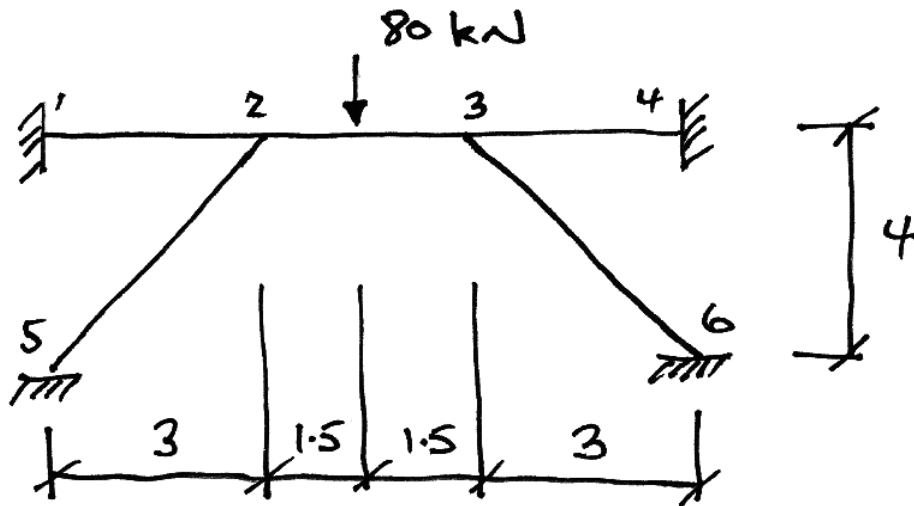

4. Determine the bending moment diagram, the rotation of joint 2, and the horizontal displacements of joints 2 and 3. Take $EI = 10 \times 10^3 \text{ kNm}^2$ and neglect axial deformations.

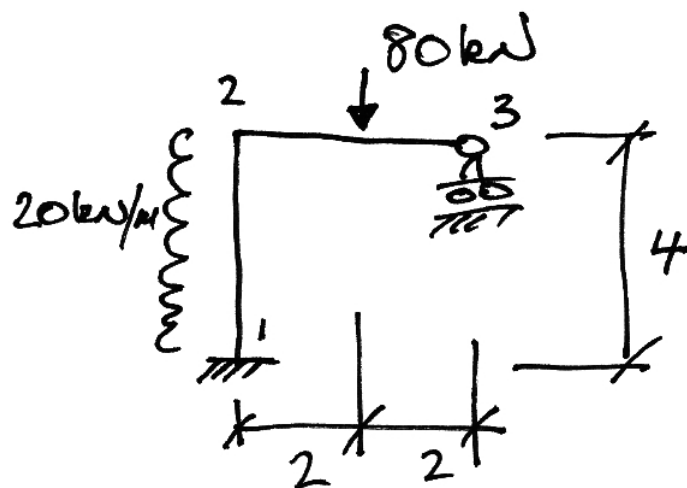

5. Appendix

5.1 Plane Truss Element Stiffness Matrix in Global Coordinates

Compatibility Conditions

Firstly we identify the conditions of compatibility of a truss element nodal deflections and the member elongation. We use the following notation for the deflections at each node of the truss:

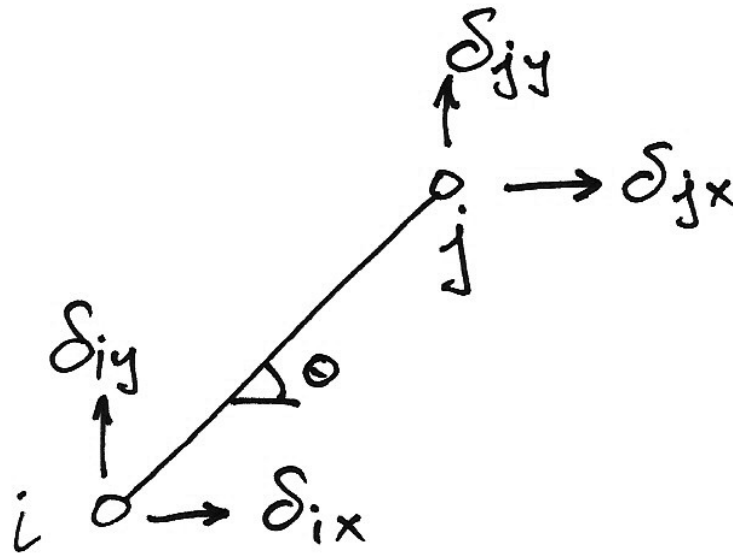

If we now consider the deflected position of the truss member, we have:

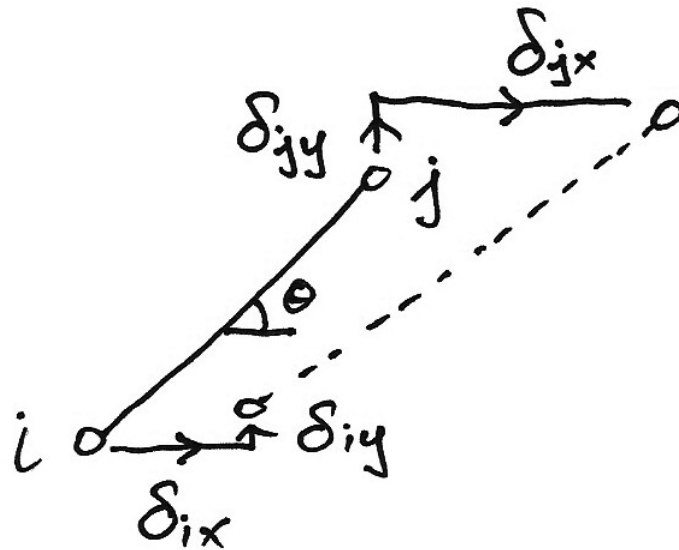

Obviously the change in length of the truss will be related to the difference between the nodal deflections. Hence, we define the changes in movements such that an elongation gives positive changes:

$$\Delta\delta_x = \delta_{jx} - \delta_{ix} \qquad \Delta\delta_y = \delta_{jy} - \delta_{iy}$$

Moving the deflected position of node i back to its original location gives:

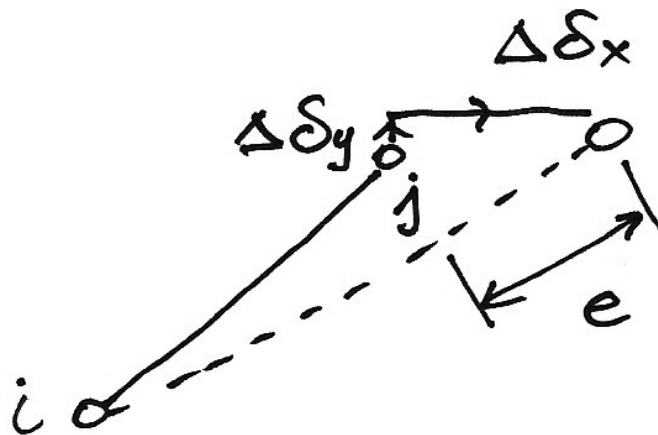

Looking more closely at the triangle of displacements at node j , and remembering that we are assuming small deflections—which in this case means the deflected position of the member is still at a rotation of θ . Hence we have:

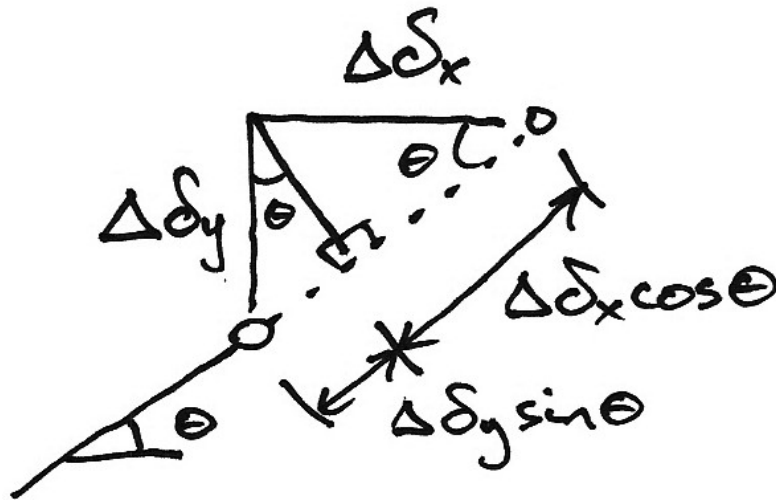

And so the elongation is given by:

$$\begin{aligned}
 e &= \Delta \delta_x \cos \theta + \Delta \delta_y \sin \theta \\
 &= (\delta_{jx} - \delta_{ix}) \cos \theta + (\delta_{jy} - \delta_{iy}) \sin \theta
 \end{aligned}
 \tag{5.1}$$

Now multiply out and re-order to get:

$$e = -\delta_{ix} \cos \theta + -\delta_{iy} \sin \theta + \delta_{jx} \cos \theta + \delta_{jy} \sin \theta
 \tag{5.2}$$

If we define a direction vector, \mathbf{a} , and a displacement vector, $\mathbf{\delta}$, as:

$$\mathbf{a} = \begin{Bmatrix} -\cos \theta \\ -\sin \theta \\ \cos \theta \\ \sin \theta \end{Bmatrix} \quad \mathbf{\delta} = \begin{Bmatrix} \delta_{ix} \\ \delta_{iy} \\ \delta_{jx} \\ \delta_{jy} \end{Bmatrix}
 \tag{5.3}$$

Then, from (5.2) and (5.3), we can say:

$$e = \boldsymbol{\alpha}'\boldsymbol{\delta} \quad (5.4)$$

Thus we have related the end displacements to the elongation of the member which therefore maintain compatibility of displacement.

Virtual Work for Element Forces

Looking at the forces acting on the nodes of the bar element, we have:

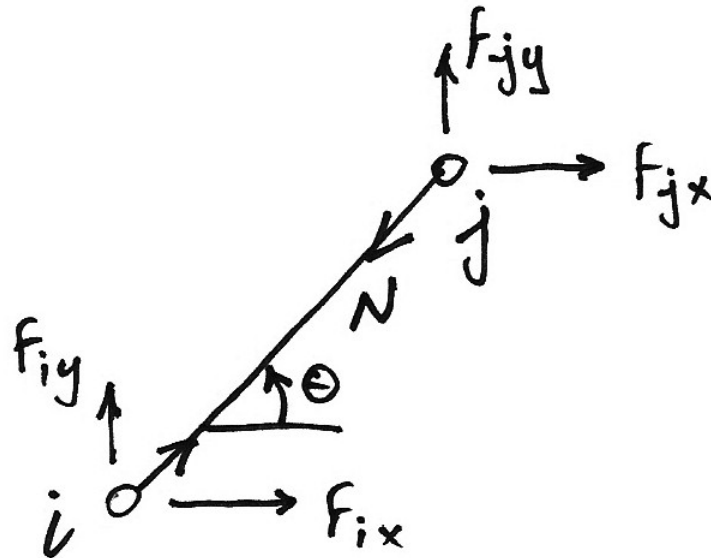

This is a force system in equilibrium—the external nodal loading is in equilibrium with the internal bar force, N . If we consider a pattern of compatible displacements such as the following:

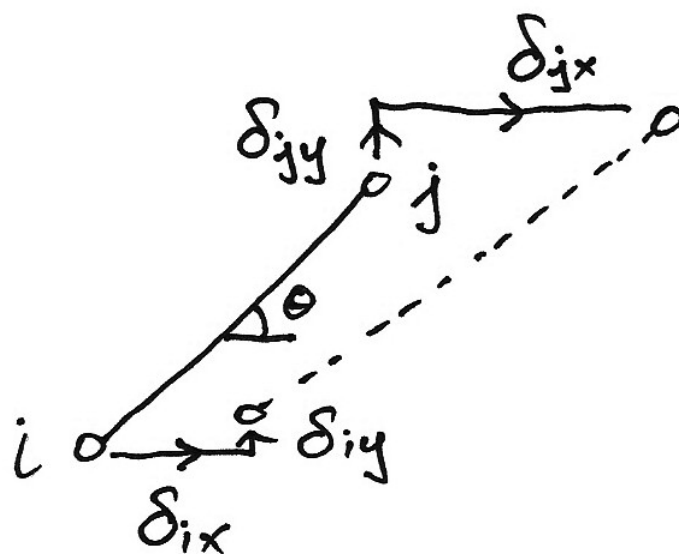

We can apply virtual work to this:

$$\delta W = 0$$

$$\delta W_E = \delta W_I$$

And we have:

Set of forces in
equilibrium

$$\sum F_i \cdot \delta y_i = \sum P_i \cdot \delta e_i$$

Set of compatible
displacements

Substituting in our notations for the bar element:

$$eN = F_{ix} \delta_{ix} + F_{iy} \delta_{iy} + F_{jx} \delta_{jx} + F_{jy} \delta_{jy} \quad (5.5)$$

If we define the force vector, \mathbf{F} , as:

$$\mathbf{F} = \begin{Bmatrix} F_{ix} \\ F_{iy} \\ F_{jx} \\ F_{jy} \end{Bmatrix} \quad (5.6)$$

Then we can write (5.5) as:

$\mathbf{F}^t \boldsymbol{\delta} = eN$	(5.7)
---	---------

If we use (5.4) we now have:

$$\mathbf{F}' \delta = \mathbf{a}' \delta N \quad (5.8)$$

Post-multiply both sides by δ^{-1} , and noting that N is a scalar, gives:

$$\mathbf{F}' = \mathbf{a}' N$$

$\mathbf{F} = \mathbf{a} N$	(5.9)
-----------------------------	-------

Expanding this out gives:

$$\begin{Bmatrix} F_{ix} \\ F_{iy} \\ F_{jx} \\ F_{jy} \end{Bmatrix} = \begin{Bmatrix} -N \cos \theta \\ -N \sin \theta \\ N \cos \theta \\ N \sin \theta \end{Bmatrix} \quad (5.10)$$

Which are the equations of equilibrium of the bar element:

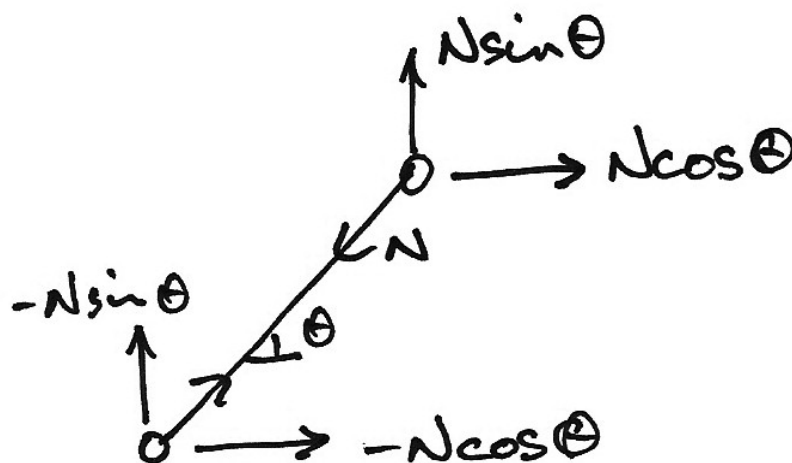

Relating Forces to Displacements

Lastly, in order to relate the end forces to the element nodal displacements, we note from the constitutive law:

$$N = \frac{EA}{L} \cdot e \quad (5.11)$$

And so from (5.9) we have:

$$\mathbf{F} = \boldsymbol{\alpha} \frac{EA}{L} e \quad (5.12)$$

And using equation (5.4) gives:

$$\mathbf{F} = \boldsymbol{\alpha} \frac{EA}{L} \boldsymbol{\alpha}' \boldsymbol{\delta} \quad (5.13)$$

Hence the term $\boldsymbol{\alpha} \frac{EA}{L} \boldsymbol{\alpha}'$ relates force to displacement and is called the stiffness matrix, \mathbf{k} , which is evaluated by multiplying out terms:

$$\begin{aligned} \mathbf{k} &= \boldsymbol{\alpha} \frac{EA}{L} \boldsymbol{\alpha}' \\ &= \frac{EA}{L} \begin{Bmatrix} -\cos \theta \\ -\sin \theta \\ \cos \theta \\ \sin \theta \end{Bmatrix} \begin{bmatrix} -\cos \theta & -\sin \theta & \cos \theta & \sin \theta \end{bmatrix} \end{aligned} \quad (5.14)$$

And multiplying this out gives:

$$\mathbf{k} = \frac{EA}{L} \begin{bmatrix} \cos^2 \theta & \cos \theta \sin \theta & -\cos^2 \theta & -\cos \theta \sin \theta \\ \cos \theta \sin \theta & \sin^2 \theta & -\cos \theta \sin \theta & -\sin^2 \theta \\ -\cos^2 \theta & -\cos \theta \sin \theta & \cos^2 \theta & \cos \theta \sin \theta \\ -\cos \theta \sin \theta & -\sin^2 \theta & \cos \theta \sin \theta & \sin^2 \theta \end{bmatrix} \quad (5.15)$$

And for clarity, we write out the final equation in matrix form and in full:

$$\mathbf{F} = \mathbf{k}\boldsymbol{\delta} \quad (5.16)$$

$$\begin{Bmatrix} F_{ix} \\ F_{iy} \\ F_{jx} \\ F_{jy} \end{Bmatrix} = \frac{EA}{L} \begin{bmatrix} \cos^2 \theta & \cos \theta \sin \theta & -\cos^2 \theta & -\cos \theta \sin \theta \\ \cos \theta \sin \theta & \sin^2 \theta & -\cos \theta \sin \theta & -\sin^2 \theta \\ -\cos^2 \theta & -\cos \theta \sin \theta & \cos^2 \theta & \cos \theta \sin \theta \\ -\cos \theta \sin \theta & -\sin^2 \theta & \cos \theta \sin \theta & \sin^2 \theta \end{bmatrix} \begin{Bmatrix} \delta_{ix} \\ \delta_{iy} \\ \delta_{jx} \\ \delta_{jy} \end{Bmatrix} \quad (5.17)$$

So for example, the stiffness that relates a horizontal force at node j to the horizontal displacement at node j is:

$$F_{jx} = \left(\frac{EA}{L} \cos^2 \theta \right) \delta_{jx}$$

And other relationships can be found similarly.

5.2 Coordinate Transformations

Point Transformation

We consider the transformation of a single point P from one coordinate axis system xy to another $x'y'$:

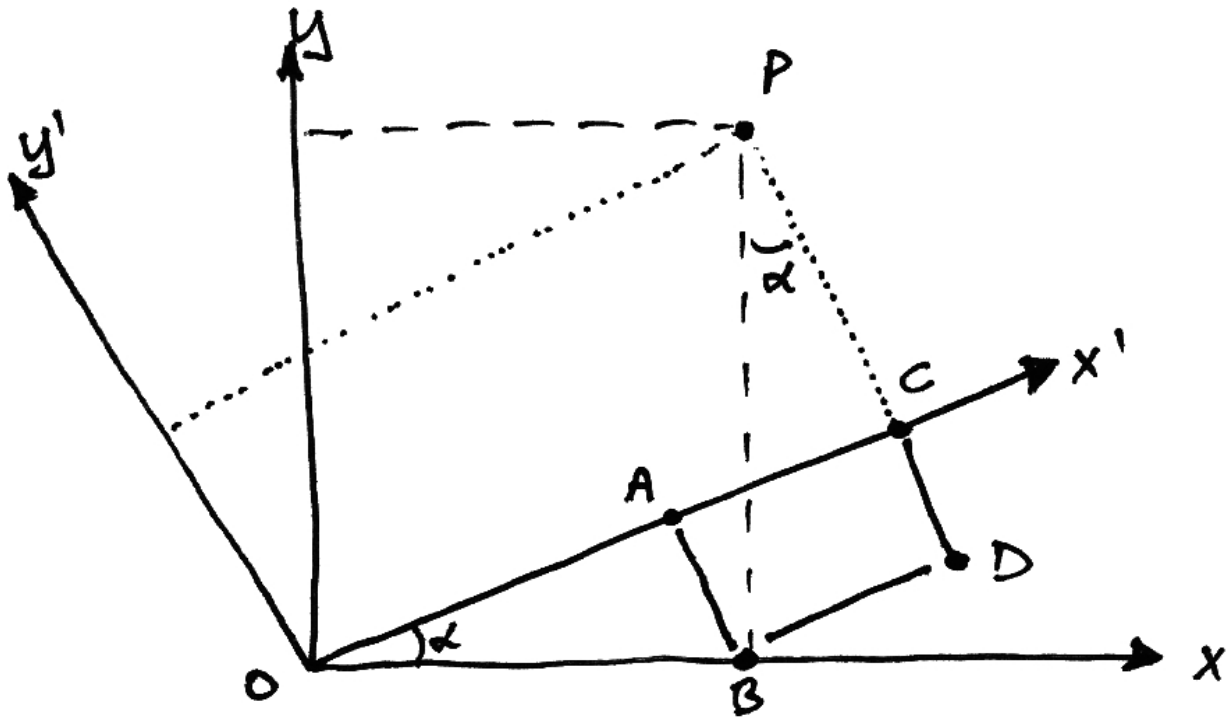

From the diagram, observe:

$$\begin{aligned} |OC| &= x' \text{ coordinate of } P \\ |PC| &= y' \text{ coordinate of } P \end{aligned} \quad (5.18)$$

Also:

$$\begin{aligned} |OB| &= x \text{ coordinate of } P \\ |PB| &= y \text{ coordinate of } P \end{aligned} \quad (5.19)$$

Next we can say:

$$|OC| = |OA| + |AC| \quad (5.20)$$

$$|PC| = |PD| - |CD| \quad (5.21)$$

Introducing the relevant coordinates:

$$|OA| = |OA| \cos \alpha = x \cos \alpha \quad (5.22)$$

$$|AC| = |BD| = |PB| \sin \alpha = y \sin \alpha \quad (5.23)$$

Thus equation (5.20) becomes:

$ OC = x' = x \cos \alpha + y \sin \alpha \quad (5.24)$
--

Next we have:

$$|PD| = |PB| \cos \alpha = y \cos \alpha \quad (5.25)$$

$$|CD| = |AB| = |OB| \sin \alpha = x \sin \alpha \quad (5.26)$$

Thus equation (5.21) becomes:

$ PC = y' = y \cos \alpha - x \sin \alpha \quad (5.27)$
--

Writing equations (5.24) and (5.27) together:

$$x' = x \cos \alpha + y \sin \alpha \quad (5.28)$$

$$y' = -x \sin \alpha + y \cos \alpha \quad (5.29)$$

And now in matrix form gives:

$$\begin{Bmatrix} x' \\ y' \end{Bmatrix} = \begin{bmatrix} \cos \alpha & \sin \alpha \\ -\sin \alpha & \cos \alpha \end{bmatrix} \begin{Bmatrix} x \\ y \end{Bmatrix} \quad (5.30)$$

Often we write:

$$\begin{aligned} c &\equiv \cos \alpha \\ s &\equiv \sin \alpha \end{aligned} \quad (5.31)$$

To give:

$$\begin{Bmatrix} x' \\ y' \end{Bmatrix} = \begin{bmatrix} c & s \\ -s & c \end{bmatrix} \begin{Bmatrix} x \\ y \end{Bmatrix} \quad (5.32)$$

Lastly, if we generically name the two coordinate systems as q and q' , we then have in matrix form:

$$\{\mathbf{q}'\} = [\mathbf{T}_N] \{\mathbf{q}\} \quad (5.33)$$

Where $[\mathbf{T}_N]$ is the nodal transformation matrix given by:

$$\mathbf{T}_N = \begin{bmatrix} \cos \alpha & \sin \alpha \\ -\sin \alpha & \cos \alpha \end{bmatrix} \quad (5.34)$$

Force/Displacement Transformation

Forces and moments can be oriented in the local member axis system or in the global structure axis system. In general we will need to transform the forces and displacements of both nodes, thus we write:

$$\begin{Bmatrix} \mathbf{F}'_i \\ \mathbf{F}'_j \end{Bmatrix} = \begin{bmatrix} \mathbf{T}_N & \mathbf{0} \\ \mathbf{0} & \mathbf{T}_N \end{bmatrix} \begin{Bmatrix} \mathbf{F}_i \\ \mathbf{F}_j \end{Bmatrix} \quad (5.35)$$

And finally we can write:

$$\{\mathbf{F}'\} = [\mathbf{T}]\{\mathbf{F}\} \quad (5.36)$$

Where:

$$[\mathbf{T}] = \begin{bmatrix} \mathbf{T}_N & \mathbf{0} \\ \mathbf{0} & \mathbf{T}_N \end{bmatrix} \quad (5.37)$$

Similarly for deflections:

$$\{\boldsymbol{\delta}'\} = [\mathbf{T}]\{\boldsymbol{\delta}\} \quad (5.38)$$

A very useful property of the transformation matrix (not derived here) is that it is orthogonal. This means that its transpose is equal to its inverse:

$$[\mathbf{T}]^T = [\mathbf{T}]^{-1} \quad (5.39)$$

Thus when either a force or displacement is known for the local axis system, it can be found in the global axis system as follows:

$$\{\mathbf{F}\} = [\mathbf{T}]^T \{\mathbf{F}'\} \quad (5.40)$$

$$\{\boldsymbol{\delta}\} = [\mathbf{T}]^T \{\boldsymbol{\delta}'\} \quad (5.41)$$

Transformations for Plane Truss Element

For a plane truss member, there will be x and y components of force at each of its nodes. Using the transformation for a point, we therefore have:

$$\begin{Bmatrix} F_{x'} \\ F_{y'} \end{Bmatrix} = \begin{bmatrix} \cos \alpha & \sin \alpha \\ -\sin \alpha & \cos \alpha \end{bmatrix} \begin{Bmatrix} F_x \\ F_y \end{Bmatrix} \quad (5.42)$$

And so for a truss element, we have directly from equation (5.34):

$$\mathbf{T}_N = \begin{bmatrix} \cos \alpha & \sin \alpha \\ -\sin \alpha & \cos \alpha \end{bmatrix} \quad (5.43)$$

And so, from equation (5.37),

$$[\mathbf{T}] = \begin{bmatrix} \cos \alpha & \sin \alpha & 0 & 0 \\ -\sin \alpha & \cos \alpha & 0 & 0 \\ 0 & 0 & \cos \alpha & \sin \alpha \\ 0 & 0 & -\sin \alpha & \cos \alpha \end{bmatrix} \quad (5.44)$$

For clarity, we write the transformation out in full:

$$\begin{Bmatrix} F_{ix'} \\ F_{iy'} \\ F_{jx'} \\ F_{jy'} \end{Bmatrix} = \begin{bmatrix} \cos \alpha & \sin \alpha & 0 & 0 \\ -\sin \alpha & \cos \alpha & 0 & 0 \\ 0 & 0 & \cos \alpha & \sin \alpha \\ 0 & 0 & -\sin \alpha & \cos \alpha \end{bmatrix} \begin{Bmatrix} F_{ix} \\ F_{iy} \\ F_{jx} \\ F_{jy} \end{Bmatrix} \quad (5.45)$$

Transformations for Plane Frame Element

Based on the DOF transformation matrix for a plane truss member (in terms of forces), we can determine the transformation matrix for a plane frame node quite easily:

$$\begin{Bmatrix} F_x^e \\ F_y^e \\ M^e \end{Bmatrix} = \begin{bmatrix} \cos \alpha & \sin \alpha & 0 \\ -\sin \alpha & \cos \alpha & 0 \\ 0 & 0 & 1 \end{bmatrix} \begin{Bmatrix} F_x \\ F_y \\ M \end{Bmatrix} \quad (5.46)$$

This is because a moment remains a moment in the plane. So for a single node, and both nodes, we have, respectively:

$$\{\mathbf{F}'\} = [\mathbf{T}_N] \{\mathbf{F}\} \quad (5.47)$$

$$\begin{Bmatrix} \mathbf{F}'_i \\ \mathbf{F}'_j \end{Bmatrix} = \begin{bmatrix} \mathbf{T}_N & \mathbf{0} \\ \mathbf{0} & \mathbf{T}_N \end{bmatrix} \begin{Bmatrix} \mathbf{F}_i \\ \mathbf{F}_j \end{Bmatrix} \quad (5.48)$$

Thus, we can now write the final transformation matrix for a plane frame element as:

$$\mathbf{T} = \left[\begin{array}{ccc|ccc} \cos \alpha & \sin \alpha & 0 & 0 & 0 & 0 \\ -\sin \alpha & \cos \alpha & 0 & 0 & 0 & 0 \\ 0 & 0 & 1 & 0 & 0 & 0 \\ \hline 0 & 0 & 0 & \cos \alpha & \sin \alpha & 0 \\ 0 & 0 & 0 & -\sin \alpha & \cos \alpha & 0 \\ 0 & 0 & 0 & 0 & 0 & 1 \end{array} \right] \quad (5.49)$$

Element Stiffness Matrix Transformation

Using the general expression for a single element:

$$\mathbf{F}^e = \mathbf{K}^e \boldsymbol{\delta}^e \quad (5.50)$$

Regardless of member type or the number of dimensions, we will always have some coordinate transform from local to global coordinates such that:

$$\mathbf{F}^e = \mathbf{T}\mathbf{F} \quad (5.51)$$

$$\boldsymbol{\delta}^e = \mathbf{T}\boldsymbol{\delta} \quad (5.52)$$

Hence from equation (5.50) we can write:

$$\mathbf{T}\mathbf{F} = \mathbf{K}^e \mathbf{T}\boldsymbol{\delta} \quad (5.53)$$

And so the force-displacement relationship in the global axis system is:

$\mathbf{F} = [\mathbf{T}^{-1} \mathbf{K}^e \mathbf{T}] \boldsymbol{\delta} \quad (5.54)$

The term in brackets can now be referred to as the element stiffness matrix in global coordinates. Thus, using equation (5.39), we write:

$\mathbf{K}_G^e = \mathbf{T}^T \mathbf{K}_L^e \mathbf{T} \quad (5.55)$
--

5.3 Past Exam Questions

Sample Paper 2006/7

1. (a) Using the stiffness method, determine the displacement of the joints of the pin-jointed truss shown in Fig. Q1(a), under the load as shown.

(10 marks)

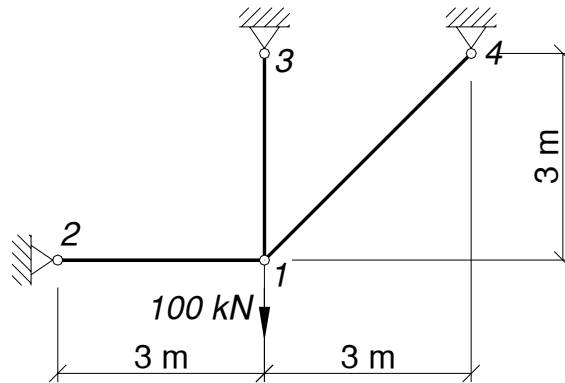

FIG. Q1(a)

- (b) Members 15 and 16 are added to the truss of Fig. 1(a) to form the truss shown in Fig. Q1(b). However, member 16 is found to be 15 mm too long and is forced into place. The same load of 100 kN is again to be applied. Using the stiffness method, determine the displacement of the joints and the force in member 16.

(15 marks)

Take $EA = 2 \times 10^4$ kN and the cross sectional areas of the members as:

Members 12, 13, and 16: $3A$;
 Diagonal Members 14 and 15: $3\sqrt{2}A$.

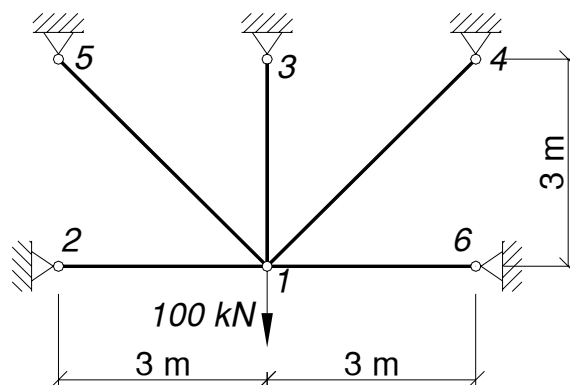

FIG. Q1(b)

Semester 1 2006/7

1. Using the stiffness method, determine the displacement of the joints and the forces in the members of the pin-jointed truss shown in Fig. Q1, allowing for:

- (i) The 100 kN vertical load as shown, and;
- (ii) A lack of fit of member 12, which was found to be 5 mm too short upon arrival at site, and which was then forced into place.

Take $EA = 2 \times 10^4$ kN and the cross sectional areas of the members as:

- Members 12: $3A$;
- Members 13 and 14: $3\sqrt{2}A$.

(25 marks)

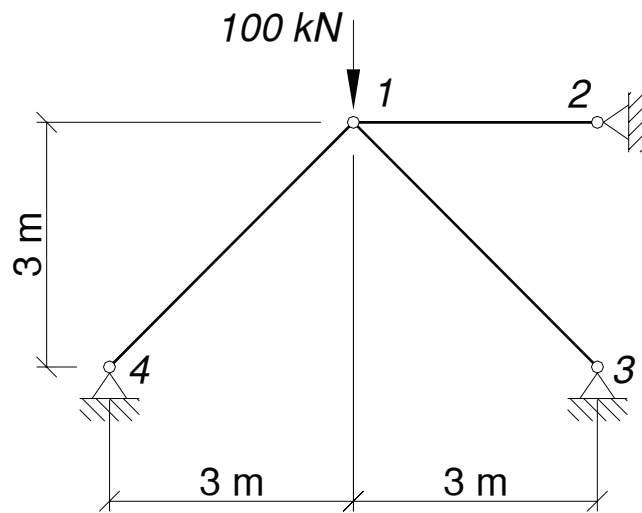

FIG. Q1

Ans. 50 kN; $-75\sqrt{2}$ kN; $-25\sqrt{2}$ kN.

Semester 1 Repeat 2006/7

1. Using the stiffness method, determine the displacement of the joints and the forces in the members of the pin-jointed truss shown in Fig. Q1, allowing for:
- (i) The 100 kN vertical load as shown, and;
 - (ii) A lack of fit of member 12, which was found to be $10\sqrt{2}$ mm too short upon arrival at site, and which was then forced into place.

Take $EA = 2 \times 10^4$ kN and the cross sectional areas of all members as $3\sqrt{2}A$.

(25 marks)

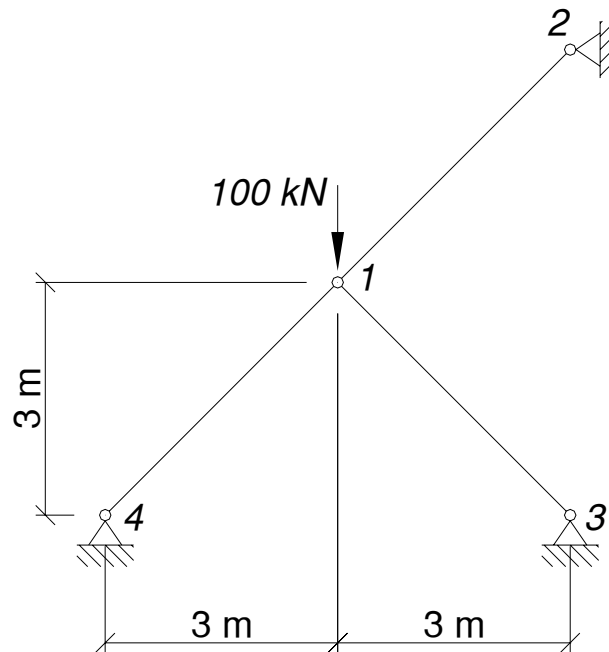

FIG. Q1

Ans. $225\sqrt{2}$ kN; $-250\sqrt{2}$ kN; $-25\sqrt{2}$ kN.

Semester 1 2007/8

QUESTION 1

Using the stiffness method, determine the displacement of the joints and the forces in the members of the pin-jointed truss shown in Fig. Q1, allowing for:

- (i) The 100 kN load as shown, and;
- (ii) A lack of fit of member 13, which was found to be 4 mm too short upon arrival at site, and which was then forced into place;
- (iii) A temperature rise of 20 °C in member 24.

Note:

Take $EA = 125 \times 10^3$ kN and the coefficient of thermal expansion $\alpha = 2 \times 10^{-5}$ °C⁻¹.

(25 marks)

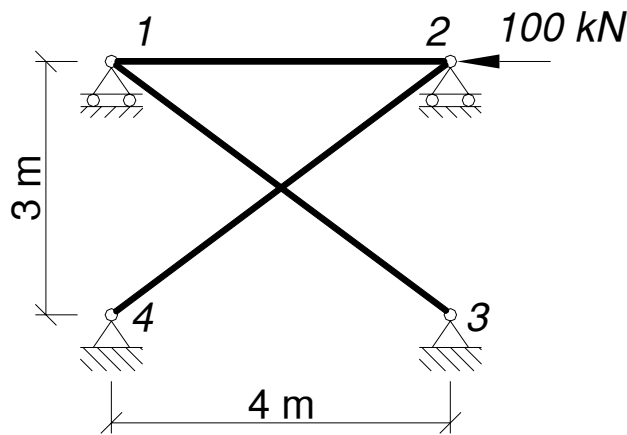

FIG. Q1

Ans. -24 kN; +229.8 kN; -195.2 kN.

Semester 1 2007/8

QUESTION 1

Using the stiffness method, for the continuous beam shown in Fig. Q1, do the following:

- (i) determine the displacement of the joints;
- (ii) draw the bending moment diagram;
- (iii) determine the reactions.

Note:

Take $EI = 10 \times 10^3 \text{ kNm}^2$.

(25 marks)

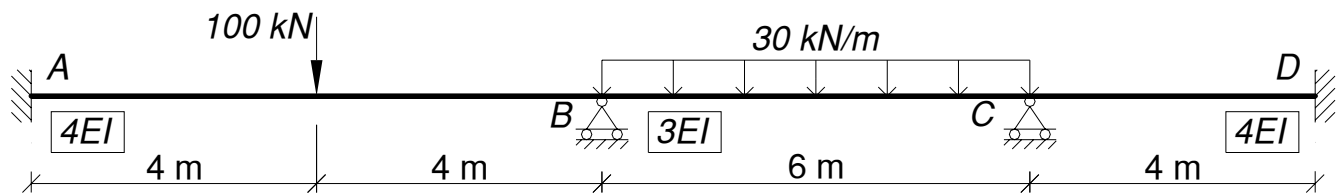

FIG. Q1

Ans. 98.7 kNm; 102.6 kNm; 60.9 kNm.

Summer 2001

1. (a) On erecting the plane pin-jointed frame shown in Fig. Q1 the member 12 is found to be 30 mm too long and is forced into place. The member 14 is then heated by 100°C . Then the external 100 kN vertical load is applied at node 1. Using the *Stiffness Method of Analysis*, determine the displacement of the joints and the forces in members 12 and 14. (20 marks)
- (b) If member 13 is removed, and the same conditions apply as in (a) above, (i.e. member 12 is 30 mm too long, member 14 is heated by 100°C , and the external 100 kN vertical load is applied at node 1), using the *Stiffness Method of Analysis*, determine the displacement of the joints. (5 marks)

Assume $EA = 2 \times 10^6 \text{ kN}$.
 Assume the coefficient of thermal expansion $\alpha = 2 \times 10^{-5}$ per $^{\circ}\text{C}$.
 The cross-sectional area of the members is as follows:

Horizontal member 12:	3A
Horizontal member 15:	2A
Diagonal member 13:	$3\sqrt{2}A$
Vertical member 14:	3A

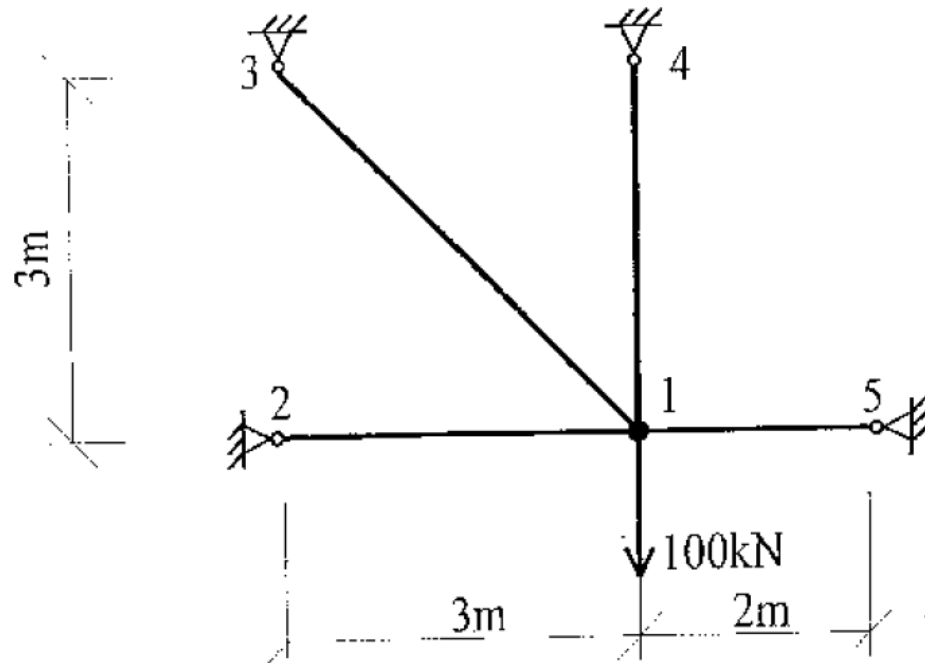

FIG. Q1

Summer 2002

1. (a) On erecting the plane pin-jointed frame shown in Fig. Q 1 the member 13 is found to be $6\sqrt{2}$ mm too long and is forced into place. The member 15 is then heated by 100°C . Then the external 100 kN vertical load is applied at node 1. Using the *Stiffness Method of Analysis*, determine the displacement of the joints and the forces in the members. (20 marks)
- (b) If member 14 is removed, and the same conditions apply as in (a) above, (i.e. member 13 is $6\sqrt{2}$ mm too long, member 15 is heated by 100°C , and the external 100 kN vertical load is applied at node 1), using the *Stiffness Method of Analysis*, determine the displacement of the joints. (5 marks)

Assume $EA = 2 \times 10^4$ kN.

Assume the coefficient of thermal expansion $\alpha = 2 \times 10^{-5}$ per $^\circ\text{C}$.

The cross-sectional area of the members is as follows:

Horizontal member 12:	3A
Horizontal member 16:	3A
Diagonal member 13	$3\sqrt{2} A$
Diagonal member 15	$3\sqrt{2} A$
Vertical member 14 :	6A

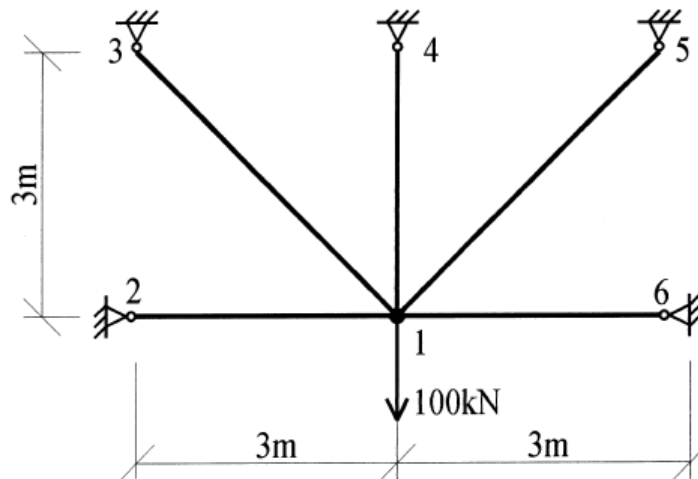

FIG. Q1

Summer 2004

1. (a) On erecting the plane pin-jointed frame shown in Fig. Q1, the members 12 and 23 were each found to be 5 mm too long and were forced into place. Then the external 200 kN vertical load was applied at node 2.

Using the Stiffness Method of Analysis, determine the displacement of the joints and the forces in members 12 and 23.

Assume $EA = 2 \times 10^4$ kN.

The cross-section area of the members is as follows:

Horizontal members 12, 23, 45, 56:	A
Diagonal members 15, 26, 24, 35:	$\sqrt{2} A$
Vertical member 25:	2 A

Note: diagonals are not interconnected at their junction. (20 marks)

(b) Identify qualitatively the forces in the other members i.e. compression, tension, or zero force. (5 marks)

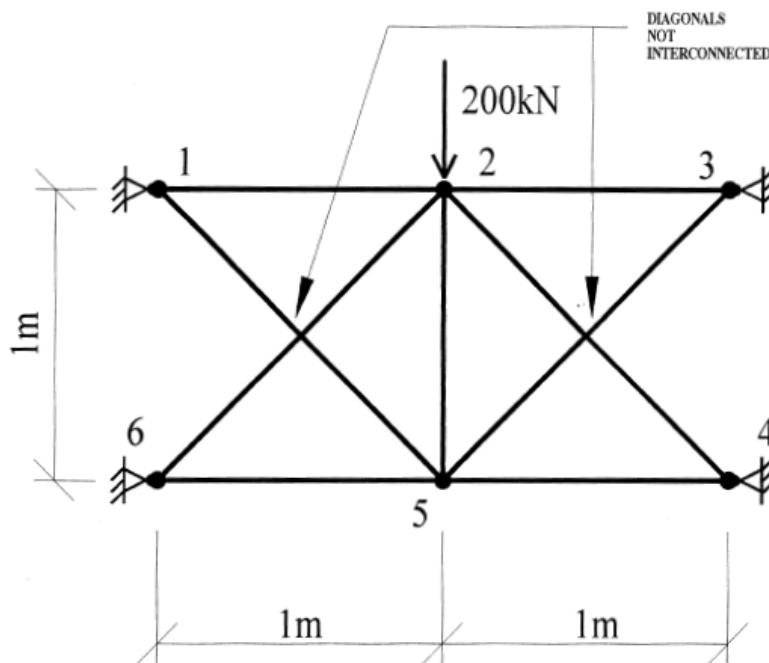

FIG. Q1

Summer 2006

1. Using the stiffness method of analysis determine the displacement of the joints and the forces in the members of the plane pin-jointed frame shown in Fig. Q1 for *each* of load cases (a) and (b) below acting *separately*:
- (a) A proposed vertical load of 100 kN to be applied at joint 1 as shown, with all members being the correct length.
 - (b) On erecting the truss if the member 12 is 5mm too short and is forced into place and then the member 15 is heated by 125 degrees C above normal, and *NO* external 100 kN load applied.

Assume $EA = 2 \times 10^4$ kN and the coefficient of thermal expansion $\alpha = 2 \times 10^{-5}$ per deg. C.

The cross-sectional area of the members is as follows:

Horizontal members 12 and 15:	A
Diagonal members 13 and 14:	$\sqrt{2} A$

(25 marks)

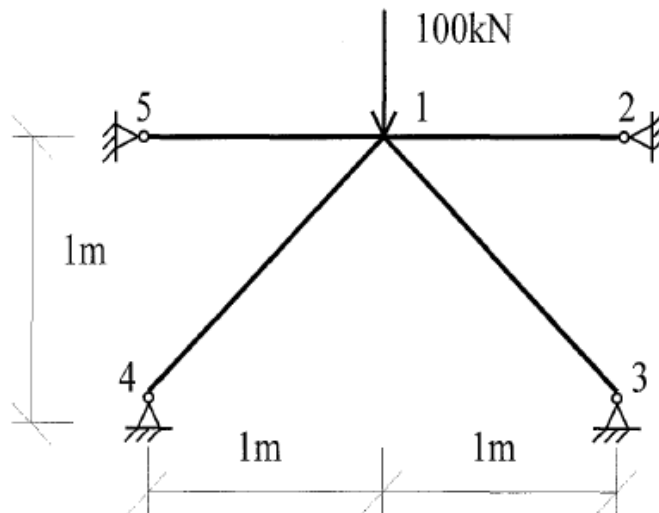

FIG. Q1