

Virtual Work – Combined Structures
4th Year
Structural Engineering

2009/10

Dr. Colin Caprani

Contents

1. Introduction	4
1.1 Purpose	4
2. Virtual Work Development.....	5
2.1 The Principle of Virtual Work.....	5
2.2 Virtual Work for Deflections.....	9
2.3 Virtual Work for Indeterminate Structures.....	10
2.4 Virtual Work for Combined Structures	12
3. Examples	14
3.1 Example 1	14
3.2 Example 2	15
3.3 Example 3	16
3.4 Example 4	22
3.5 Further Examples.....	29
4. Exercises	30
4.1 Problems	30
4.2 Past Exam Questions	32
5. Appendix – Trigonometric Integrals.....	36
5.1 Useful Identities.....	36
5.2 Basic Results.....	37
5.3 Common Integrals	38
6. Appendix – Volume Integrals.....	45
7. Ring Beam Examples (Advanced)	46
7.1 Example 1	46
7.2 Example 2	51
7.3 Example 3	58
7.4 Example 4	66
7.5 Example 5	75

7.6 Review of Examples 1 – 5 96

1. Introduction

1.1 Purpose

Previously we only used virtual work to analyse structures whose members primarily behaved in flexure or in axial forces. Many real structures are comprised of a mixture of such members. Cable-stay and suspension bridges are good examples: the deck-level carries load primarily through bending whilst the cable and pylon elements carry load through axial forces mainly. A simple example is:

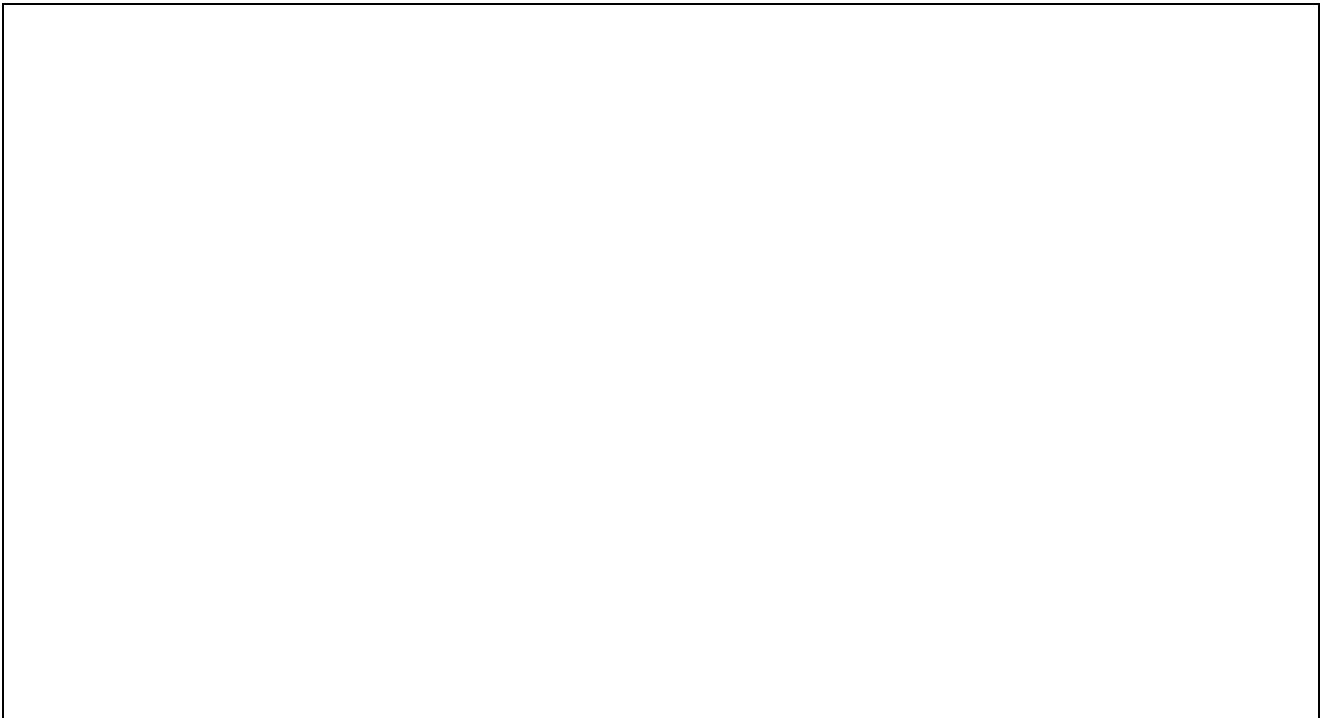

Our knowledge of virtual work to-date is sufficient to analyse such structures.

2. Virtual Work Development

2.1 *The Principle of Virtual Work*

This states that:

A body is in equilibrium if, and only if, the virtual work of all forces acting on the body is zero.

In this context, the word ‘virtual’ means ‘having the effect of, but not the actual form of, what is specified’.

There are two ways to define virtual work, as follows.

1. Virtual Displacement:

Virtual work is the work done by the actual forces acting on the body moving through a virtual displacement.

2. Virtual Force:

Virtual work is the work done by a virtual force acting on the body moving through the actual displacements.

Virtual Displacements

A virtual displacement is a displacement that is only imagined to occur:

- virtual displacements must be small enough such that the force directions are maintained.
- virtual displacements within a body must be geometrically compatible with the original structure. That is, geometrical constraints (i.e. supports) and member continuity must be maintained.

Virtual Forces

A virtual force is a force imagined to be applied and is then moved through the actual deformations of the body, thus causing virtual work.

Virtual forces must form an equilibrium set of their own.

Internal and External Virtual Work

When a structure deforms, work is done both by the applied loads moving through a displacement, as well as by the increase in strain energy in the structure. Thus when virtual displacements or forces are causing virtual work, we have:

$$\begin{aligned}\delta W &= 0 \\ \delta W_I - \delta W_E &= 0 \\ \delta W_E &= \delta W_I\end{aligned}$$

where

- Virtual work is denoted δW and is zero for a body in equilibrium;
- External virtual work is δW_E , and;
- Internal virtual work is δW_I .

And so the external virtual work must equal the internal virtual work. It is in this form that the Principle of Virtual Work finds most use.

Application of Virtual Displacements

For a virtual displacement we have:

$$\begin{aligned}\delta W &= 0 \\ \delta W_E &= \delta W_I \\ \sum F_i \cdot \delta y_i &= \sum P_i \cdot \delta e_i\end{aligned}$$

In which, for the external virtual work, F_i represents an externally applied force (or moment) and δy_i its virtual displacement. And for the internal virtual work, P_i represents the internal force (or moment) in member i and δe_i its virtual deformation. The summations reflect the fact that all work done must be accounted for.

Remember in the above, each the displacements must be compatible and the forces must be in equilibrium, summarized as:

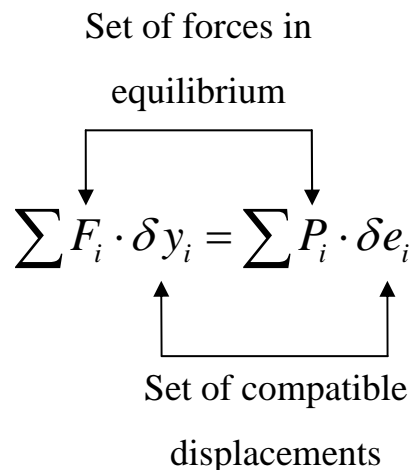

Application of Virtual Forces

When virtual forces are applied, we have:

$$\begin{aligned}\delta W &= 0 \\ \delta W_E &= \delta W_I \\ \sum y_i \cdot \delta F_i &= \sum e_i \cdot \delta P_i\end{aligned}$$

And again note that we have an equilibrium set of forces and a compatible set of displacements:

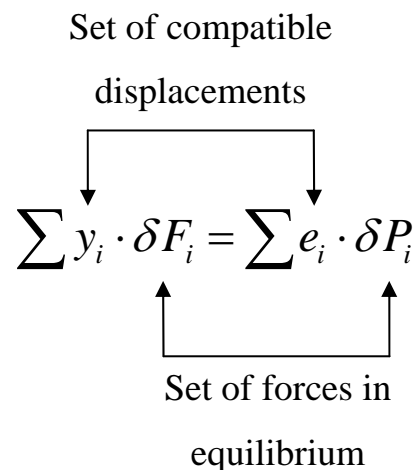

In this case the displacements are the real displacements that occur when the structure is in equilibrium and the virtual forces are any set of arbitrary forces that are in equilibrium.

2.2 Virtual Work for Deflections

Deflections in Beams and Frames

For a beam we proceed as:

1. Write the virtual work equation for bending:

$$\begin{aligned}\delta W &= 0 \\ \delta W_E &= \delta W_I \\ y \cdot \delta F &= \sum \theta_i \cdot \delta M_i\end{aligned}$$

2. Place a unit load, δF , at the point at which deflection is required;
3. Find the real bending moment diagram, M_x , since the real curvatures are given by:

$$\theta_x = \frac{M_x}{EI_x}$$

4. Solve for the virtual bending moment diagram (the virtual force equilibrium set), δM , caused by the virtual unit load.
5. Solve the virtual work equation:

$$y \cdot 1 = \int_0^L \left[\frac{M_x}{EI} \right] \cdot \delta M_x dx$$

6. Note that the integration tables can be used for this step.

2.3 Virtual Work for Indeterminate Structures

General Approach

Using compatibility of displacement, we have:

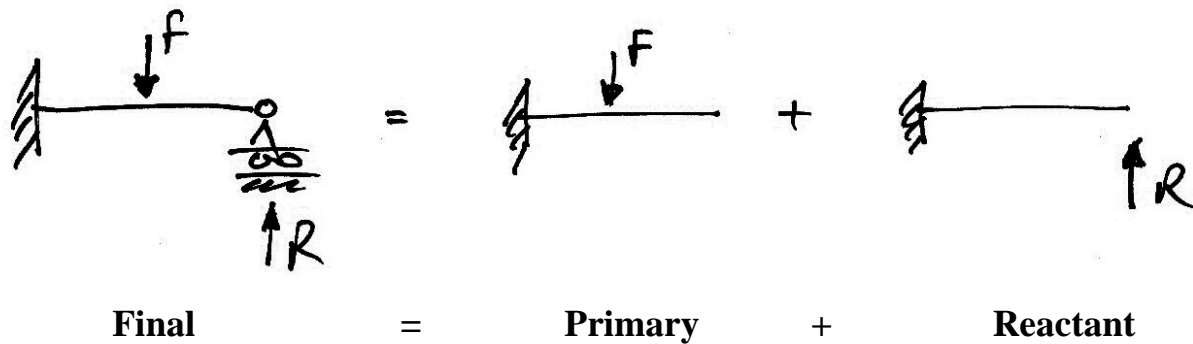

Next, further break up the reactant structure, using linear superposition:

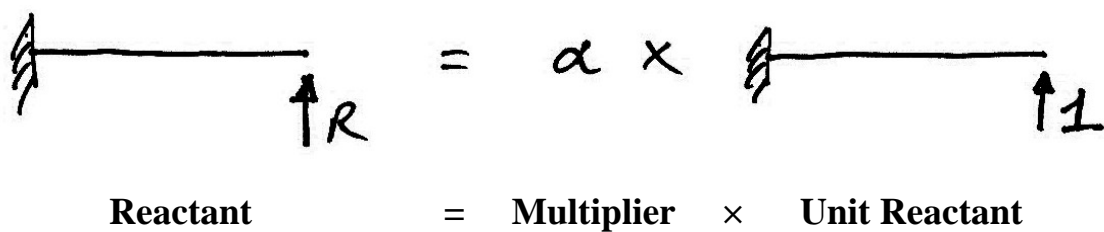

We summarize this process as:

$$M = M^0 + \alpha M^1$$

- M is the force system in the original structure (in this case moments);
- M^0 is the primary structure force system;
- M^1 is the unit reactant structure force system.

The primary structure can be analysed, as can the unit reactant structure. Thus, the only unknown is the multiplier, α , for which we use virtual work to calculate.

Finding the Multiplier

For beams and frames, we have:

$$0 = \sum \int_0^L \frac{M^0 \cdot \delta M_i^1}{EI_i} dx + \alpha \cdot \sum \int_0^L \frac{(\delta M_i^1)^2}{EI_i} dx$$

Thus:

$$\alpha = \frac{-\sum \int_0^L \frac{M^0 \cdot \delta M_i^1}{EI_i} dx}{\sum \int_0^L \frac{(\delta M_i^1)^2}{EI_i} dx}$$

2.4 Virtual Work for Combined Structures

Basis

The virtual work that is done in a truss member is exactly the same concept as the virtual work done in a beam element. Thus the virtual work for a structure comprised of both types of members is just:

$$\begin{aligned}\delta W &= 0 \\ \delta W_E &= \delta W_I \\ \sum y_i \cdot \delta F_i &= \sum e_i \cdot \delta P_i + \sum \theta_i \cdot \delta M_i\end{aligned}$$

In which the first term on the RHS is the internal virtual work done by any truss members and the second term is that done by any flexural members.

If a deflection is sought:

$$\begin{aligned}y \cdot \delta F &= \sum e_i \cdot \delta P_i + \sum \theta_i \cdot \delta M_i \\ y \cdot 1 &= \sum \left(\frac{PL}{EA} \right)_i \cdot \delta P_i + \sum \int_0^L \left[\frac{M_x}{EI} \right] \cdot \delta M_x dx\end{aligned}$$

To solve for an indeterminate structure, we have both:

$$\begin{aligned}M &= M^0 + \alpha M^1 \\ P &= P^0 + \alpha P^1\end{aligned}$$

for the structure as a whole. Hence we have:

$$\delta W = 0$$

$$\delta W_E = \delta W_I$$

$$\sum y_i \cdot \delta F_i = \sum e_i \cdot \delta P_i + \sum \theta_i \cdot \delta M_i$$

$$0 \cdot 1 = \sum \left(\frac{PL}{EA} \right)_i \cdot \delta P_i^1 + \sum \int_0^L \left[\frac{M_x}{EI} \right] \cdot \delta M_x dx$$

$$0 = \sum \left(\frac{(P^0 + \alpha \cdot \delta P^1)L}{EA} \right)_i \cdot \delta P_i^1 + \sum \int_0^L \left[\frac{(M_x^0 + \alpha M_x^1)}{EI} \right] \cdot \delta M_x dx$$

$$0 = \sum \left(\frac{P^0 L}{EA} \right)_i \cdot \delta P_i^1 + \alpha \cdot \sum \left(\frac{\delta P^1 L}{EA} \right)_i \cdot \delta P_i^1 + \sum \int_0^L \frac{M_x^0 \cdot \delta M_x^1}{EI} dx + \alpha \cdot \sum \int_0^L \frac{(\delta M_x^1)^2}{EI} dx$$

Hence the multiplier can be found as:

$$\alpha = - \frac{\sum \frac{P^0 \cdot \delta P_i^1 \cdot L_i}{EA_i} + \sum \int_0^L \frac{M^0 \cdot \delta M_i^1}{EI_i} dx}{\sum \frac{(\delta P_i^1)^2 L_i}{EA_i} + \sum \int_0^L \frac{(\delta M_i^1)^2}{EI_i} dx}$$

Note the negative sign!

Though these expressions are cumbersome, the ideas and the algebra are both simple.

Integration of Bending Moments

We are often faced with the integration of bending moment diagrams when using virtual work to calculate the deflections of bending members. And as bending moment diagrams only have a limited number of shapes, a table of ‘volume’ integrals is used.

3. Examples

3.1 Example 1

Problem

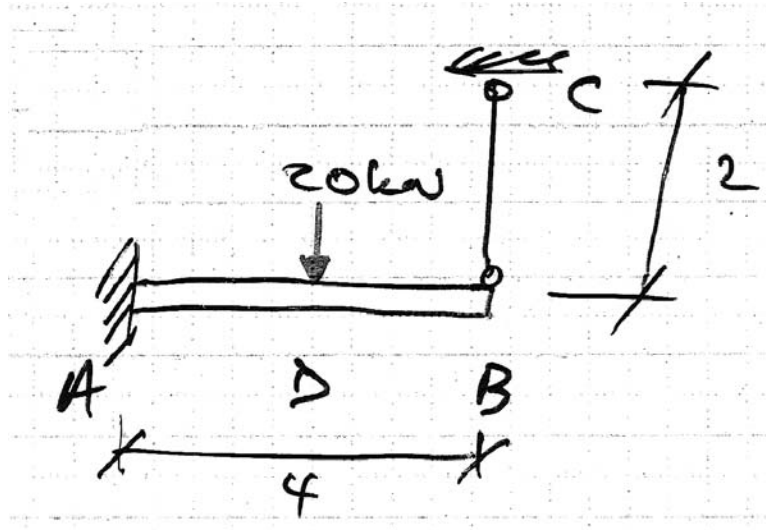

Take $EI = 8 \times 10^3 \text{ kNm}^2$ and $EA = 16 \times 10^3 \text{ kN}$.

Solution

To be done in Class.

3.2 Example 2

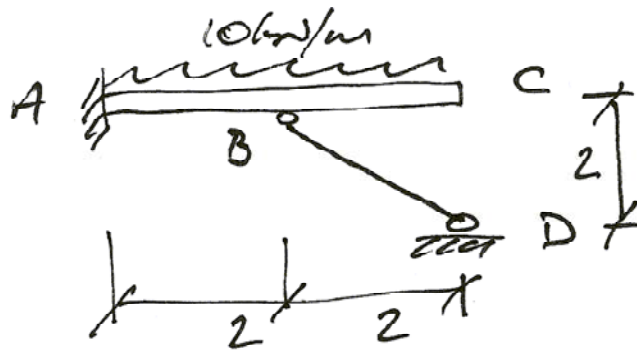

$$EI = 8 \times 10^3 \text{ kNm}^2$$

$$k_A = 16 \times 10^3 \text{ kN/m}$$

Find the BMD and SFD

3.3 Example 3

Problem

For the following structure, find:

- (a) The force in the cable CD and the bending moment diagram;
- (b) Determine the optimum length of the cable for maximum efficiency of the beam.

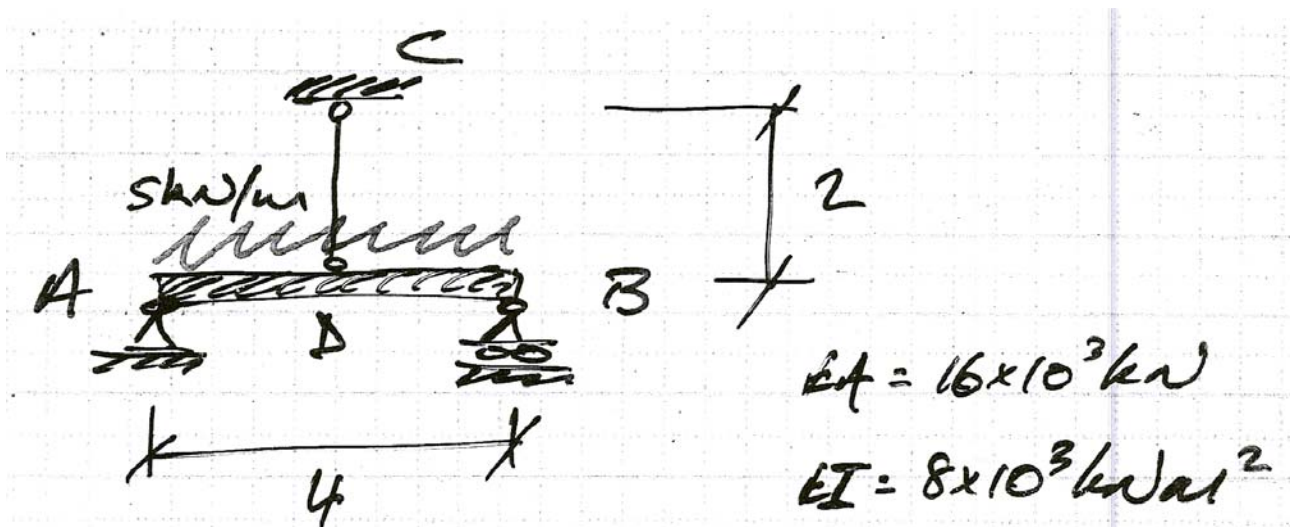

Part (a)

To be done in class.

Part (b)

Efficiency of the beam means that the moments are resisted by the smallest possible beam. Thus the largest moment anywhere in the beam must be made as small as possible. Therefore the hogging and sagging moments should be equal:

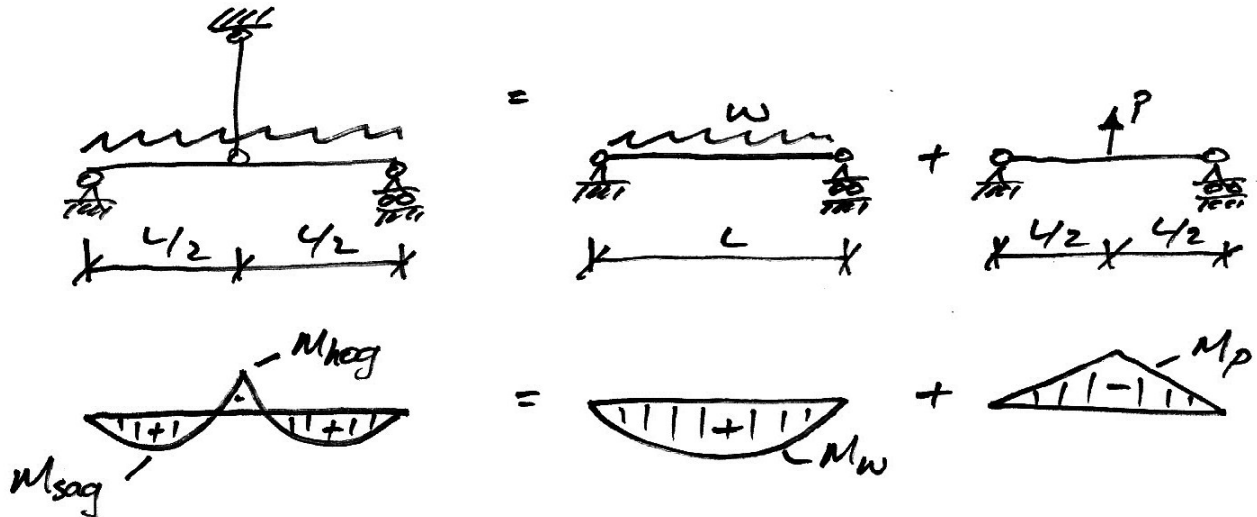

We know that the largest hogging moment will occur at $L/2$. However, we do not know where the largest sagging moment will occur. Lastly, we will consider sagging moments positive and hogging moments negative. Consider the portion of the net bending moment diagram, $M(x)$, from 0 to $L/2$:

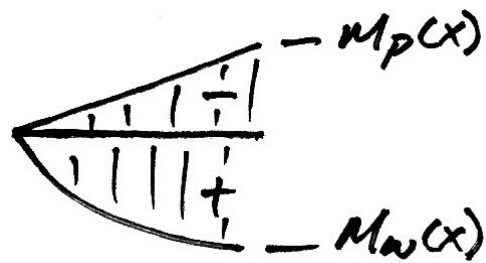

The equations of these bending moments are:

$$M_p(x) = -\frac{P}{2}x$$

$$M_w(x) = -\frac{w}{2}x^2 + \frac{wL}{2}x$$

Thus:

$$\begin{aligned} M(x) &= M_w(x) + M_p(x) \\ &= \frac{wL}{2}x - \frac{w}{2}x^2 - \frac{P}{2}x \end{aligned}$$

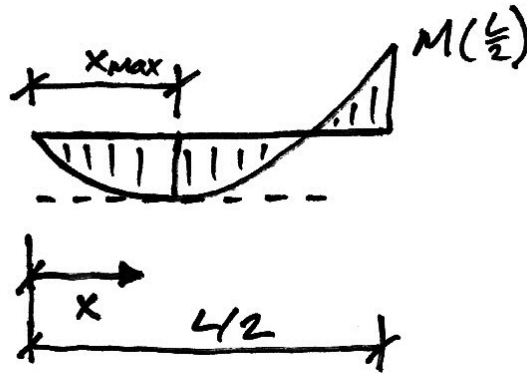

The moment at $L/2$ is:

$$\begin{aligned} M(L/2) &= \frac{wL}{2} \left(\frac{L}{2} \right) - \frac{w}{2} \left(\frac{L}{2} \right)^2 - \frac{P}{2} \left(\frac{L}{2} \right) \\ &= \frac{wL^2}{4} - \frac{wL^2}{8} - \frac{PL}{4} \\ &= \frac{wL^2}{8} - \frac{PL}{4} \end{aligned}$$

Which is as we expected. The maximum sagging moment between 0 and $L/2$ is found at:

$$\begin{aligned}\frac{dM(x)}{dx} &= 0 \\ \frac{wL}{2} - wx_{\max} - \frac{P}{2} &= 0 \\ x_{\max} &= \frac{L}{2} - \frac{P}{2w}\end{aligned}$$

Thus the maximum sagging moment has a value:

$$\begin{aligned}M(x_{\max}) &= \frac{wL}{2} \left(\frac{L}{2} - \frac{P}{2w} \right) - \frac{w}{2} \left(\frac{L}{2} - \frac{P}{2w} \right)^2 - \frac{P}{2} \left(\frac{L}{2} - \frac{P}{2w} \right) \\ &= \frac{wL^2}{4} - \frac{PL}{4} - \frac{w}{2} \left(\frac{L^2}{4} - \frac{2PL}{4w} + \frac{P^2}{4w} \right) - \frac{PL}{4} + \frac{P^2}{4w} \\ &= \frac{wL^2}{8} - \frac{PL}{4} + \frac{P^2}{8w}\end{aligned}$$

Since we have assigned a sign convention, the sum of the hogging and sagging moments should be zero, if we are to achieve the optimum BMD. Thus:

$$\begin{aligned}M(x_{\max}) + M(L/2) &= 0 \\ \left[\frac{wL^2}{8} - \frac{PL}{4} + \frac{P^2}{8w} \right] + \left[\frac{wL^2}{8} - \frac{PL}{4} \right] &= 0 \\ \frac{wL^2}{4} - \frac{PL}{2} + \frac{P^2}{8w} &= 0 \\ \left(\frac{1}{8w} \right) P^2 + \left(-\frac{L}{2} \right) P + \left(\frac{wL^2}{4} \right) &= 0\end{aligned}$$

This is a quadratic equation in P and so we solve for P using the usual:

$$\begin{aligned}
 P &= \frac{\frac{L}{2} \pm \sqrt{\frac{L^2}{4} - \frac{L^2}{8}}}{\frac{L}{8w}} \\
 &= \frac{8w}{2} \left(\frac{L}{2} \pm \frac{L}{\sqrt{8}} \right) \\
 &= wL(2 \pm \sqrt{2})
 \end{aligned}$$

Since the load in the cable must be less than the total amount of load in the beam, that is, $P < wL$, we have:

$$P = wL(2 - \sqrt{2}) = 0.586wL$$

With this value for P we can determine the hogging and sagging moments:

$$\begin{aligned}
 M(L/2) &= \frac{wL^2}{8} - \frac{wL(2 - \sqrt{2})L}{4} \\
 &= wL^2 \left(\frac{2\sqrt{2} - 3}{8} \right) \\
 &= -0.0214wL^2
 \end{aligned}$$

And:

$$\begin{aligned}
 M(x_{\max}) &= \left(\frac{wL^2}{8} - \frac{PL}{4} \right) + \frac{P^2}{8w} \\
 &= wL^2 \left(\frac{2\sqrt{2} - 3}{8} \right) + \frac{[wL(2 - \sqrt{2})]^2}{8w} \\
 &= wL^2 \left(\frac{3 - 2\sqrt{2}}{8} \right) \\
 &= +0.0214wL^2
 \end{aligned}$$

Lastly, the location of the maximum sagging moment is given by:

$$\begin{aligned}x_{\max} &= \frac{L}{2} - \frac{P}{2w} \\ &= \frac{L}{2} - \frac{wL(2 - \sqrt{2})}{2w} \\ &= \frac{L}{2}(\sqrt{2} - 1) \\ &= 0.207L\end{aligned}$$

For our particular problem, $w = 5 \text{ kN/m}$, $L = 4 \text{ m}$, giving:

$$P = 0.586(5 \times 4) = 11.72 \text{ kN}$$

$$M(x_{\max}) = 0.0214(5 \times 4^2) = 1.71 \text{ kNm}$$

Thus, as we expected, $P > 10 \text{ kN}$, the value obtained from Part (a) of the problem.

Now since, we know P we now also know the required value of the multiplier, α . Hence, we write the virtual work equations again, but this time keeping Term 2 in terms of L , since that is what we wish to solve for:

$$\begin{aligned}0 &= \alpha \left(\frac{L}{16 \times 10^3} \right) - 2.083 \times 10^{-3} + \alpha (8.33 \times 10^{-5}) \\ \alpha &= \frac{2.083 \times 10^{-3}}{\frac{L}{16 \times 10^3} + 8.33 \times 10^{-5}} = 11.72\end{aligned}$$

Giving, $L = 1.51 \text{ m}$ as the solution.

3.4 Example 4

For the following structure:

1. Determine the tension in the cable AB ;
2. Draw the bending moment diagram;
3. Determine the vertical deflection at D with and without the cable AB .

Take $EI = 120 \times 10^3 \text{ kNm}^2$ and $EA = 60 \times 10^3 \text{ kN}$.

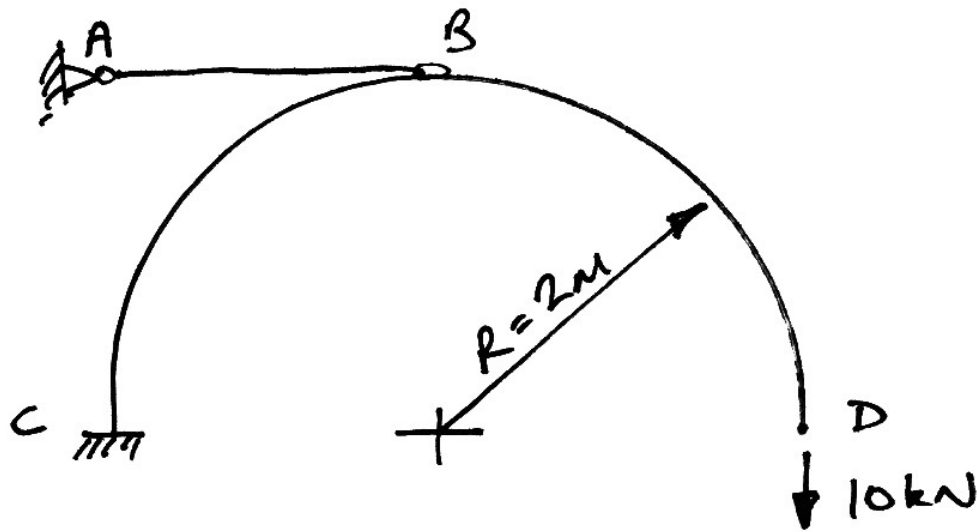

As is usual, we choose the cable to be the redundant member and split the frame up as follows:

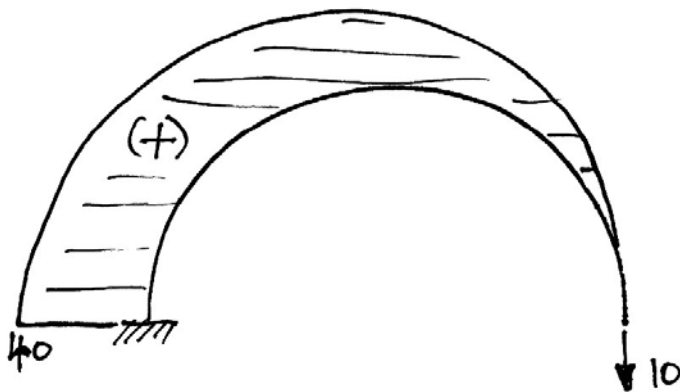

Primary Structure

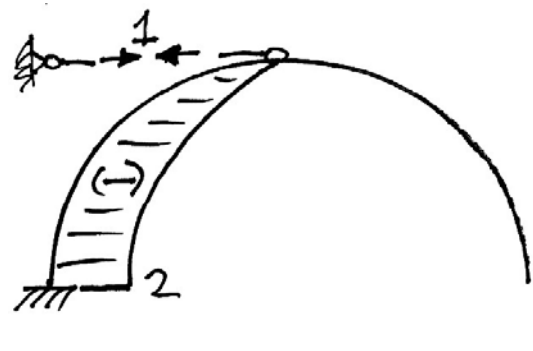

Redundant Structure

We must examine the BMDs carefully, and identify expressions for the moments around the arch. However, since we will be using virtual work and integrating one diagram against another, we immediately see that we are only interested in the portion of the structure CB . Further, we will use the anti-clockwise angle from vertical as the basis for our integration.

Primary BMD

Drawing the BMD and identify the relevant distances:

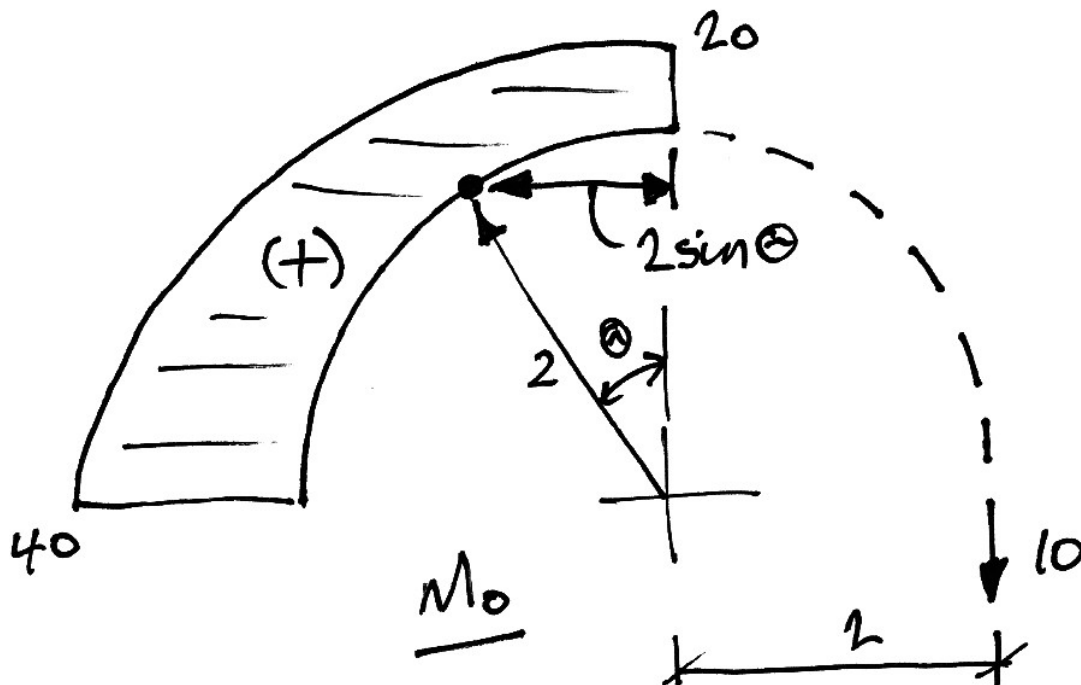

Hence the expression for M^θ is:

$$M_\theta^0 = 20 + 10(2 \sin \theta) = 20(1 + \sin \theta)$$

Reactant BMD

This calculation is slightly easier:

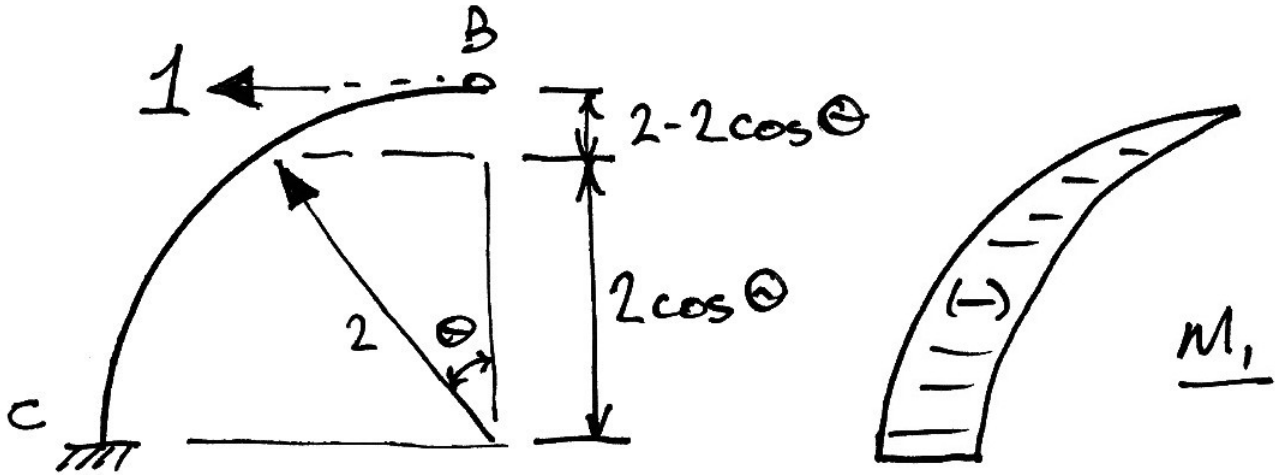

$$M_{\theta}^1 = 1 \cdot (2 - 2 \cos \theta) = 2(1 - \cos \theta)$$

Virtual Work Equation

As before, we have the equation:

$$0 = \sum \left(\frac{P^0 L}{EA} \right)_i \cdot \delta P_i^1 + \alpha \cdot \sum \left(\frac{\delta P^1 L}{EA} \right)_i \cdot \delta P_i^1 + \sum \int_0^L \frac{M_x^0 \cdot \delta M_x^1}{EI} dx + \alpha \cdot \sum \int_0^L \frac{(\delta M_x^1)^2}{EI} dx$$

Term 1 is zero since there are no axial forces in the primary structure. We take each other term in turn.

Term 2

Since only member AB has axial force:

$$\text{Term 2} = \frac{(1)^2 \cdot 2}{EA} = \frac{2}{EA}$$

Term 3

Since we want to integrate around the member – an integrand ds - but only have the moment expressed according to θ , we must change the integration limits by substituting:

$$ds = R \cdot d\theta = 2d\theta$$

Hence:

$$\begin{aligned} \sum \int_0^L \frac{M_x^0 \cdot \delta M_x^1}{EI} dx &= \frac{1}{EI} \int_0^{\pi/2} [-2(1 - \cos \theta)][20(1 + \sin \theta)] 2d\theta \\ &= \frac{80}{EI} \int_0^{\pi/2} (-1 + \cos \theta)(1 + \sin \theta) d\theta \\ &= \frac{80}{EI} \int_0^{\pi/2} (-1 - \sin \theta + \cos \theta + \cos \theta \sin \theta) d\theta \end{aligned}$$

To integrate this expression we refer to the appendix of integrals to get each of the terms, which then give:

$$\begin{aligned} \sum \int_0^L \frac{M_x^0 \cdot \delta M_x^1}{EI} dx &= \frac{80}{EI} \left[-\theta + \cos \theta + \sin \theta - \frac{1}{4} \cos 2\theta \right]_0^{\pi/2} \\ &= \frac{80}{EI} \left\{ \left[-\frac{\pi}{2} + 0 + 1 - \frac{1}{4}(-1) \right] - \left[-0 + 1 + 0 - \frac{1}{4} \right] \right\} \\ &= \frac{80}{EI} \left(-\frac{\pi}{2} + 1 + \frac{1}{4} - 1 + \frac{1}{4} \right) \\ &= \frac{80}{EI} \left(\frac{1 - \pi}{2} \right) \end{aligned}$$

Term 4

Proceeding similarly to Term 3, we have:

$$\begin{aligned} \sum \int_0^L \frac{(\delta M_x^1)^2}{EI} dx &= \frac{1}{EI} \int_0^{\pi/2} [2(1 - \cos \theta)] [2(1 - \cos \theta)] 2d\theta \\ &= \frac{8}{EI} \int_0^{\pi/2} (1 - 2\cos \theta + \cos^2 \theta) d\theta \end{aligned}$$

Again we refer to the integrals appendix, and so for Term 4 we then have:

$$\begin{aligned} \sum \int_0^L \frac{(\delta M_x^1)^2}{EI} dx &= \frac{8}{EI} \int_0^{\pi/2} (1 - 2\cos \theta + \cos^2 \theta) d\theta \\ &= \frac{8}{EI} \left[\theta - 2\sin \theta + \left(\frac{\theta}{2} + \frac{1}{4} \sin 2\theta \right) \right]_0^{\pi/2} \\ &= \frac{8}{EI} \left\{ \left[\frac{\pi}{2} - 2 + \left(\frac{\pi}{4} + \frac{1}{4} \right) \right] - [0 - 0 + 0 + 0] \right\} \\ &= \frac{8}{EI} \left(\frac{3\pi - 7}{4} \right) \end{aligned}$$

Solution

Substituting the calculated values into the virtual work equation gives:

$$0 = 0 + \alpha \cdot \frac{2}{EA} + \frac{80}{EI} \left(\frac{1 - \pi}{2} \right) + \alpha \cdot \frac{8}{EI} \left(\frac{3\pi - 7}{4} \right)$$

And so:

$$\alpha = \frac{-\frac{80}{EI} \left(\frac{1-\pi}{2} \right)}{\frac{2}{EA} + \frac{8}{EI} \left(\frac{3\pi-7}{4} \right)}$$

Simplifying:

$$\alpha = \frac{20\pi - 20}{3\pi - 7 + \frac{EI}{EA}}$$

In this problem, $EI/EA = 2$ and so:

$$\alpha = \frac{20\pi - 20}{3\pi - 5} = 9.68 \text{ kN}$$

We can examine the effect of different ratios of EI/EA on the structure from our algebraic solution for α . We show this, as well as a point representing the solution for this particular EI/EA ratio on the following graph:

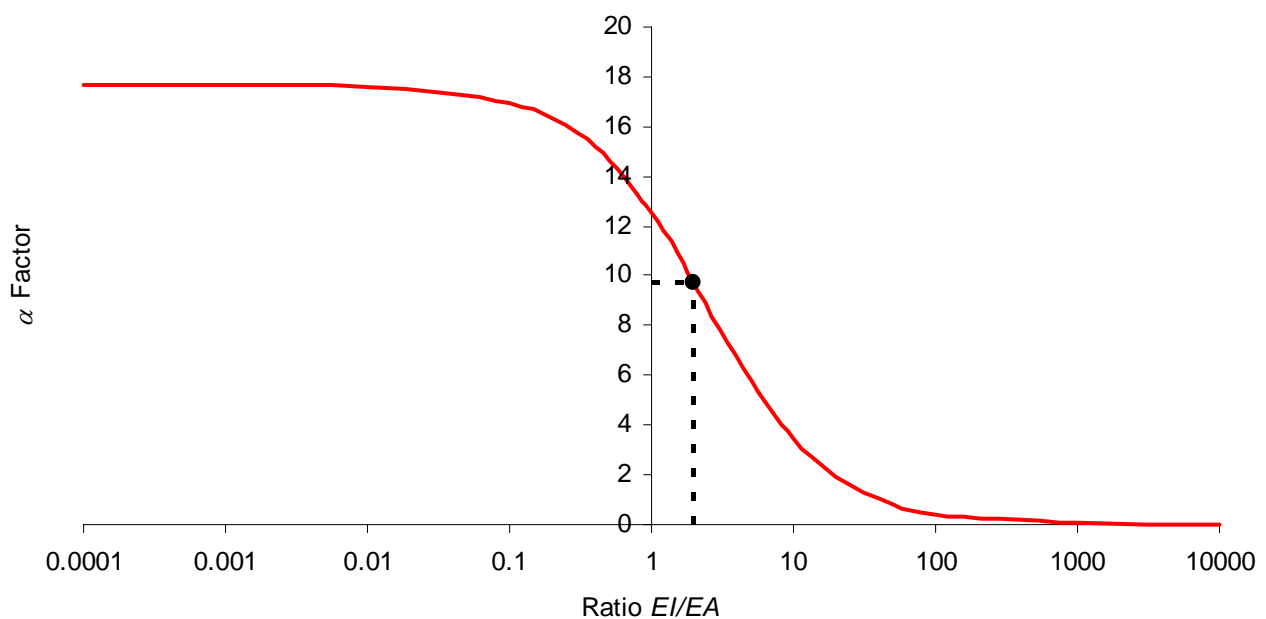

As can be seen, by choosing a stiffer frame member (increasing EI) or by reducing the area of the cable, we can reduce the force in the cable (which is just $1 \cdot \alpha$). However this will have the effect of increasing the moment at A, for example:

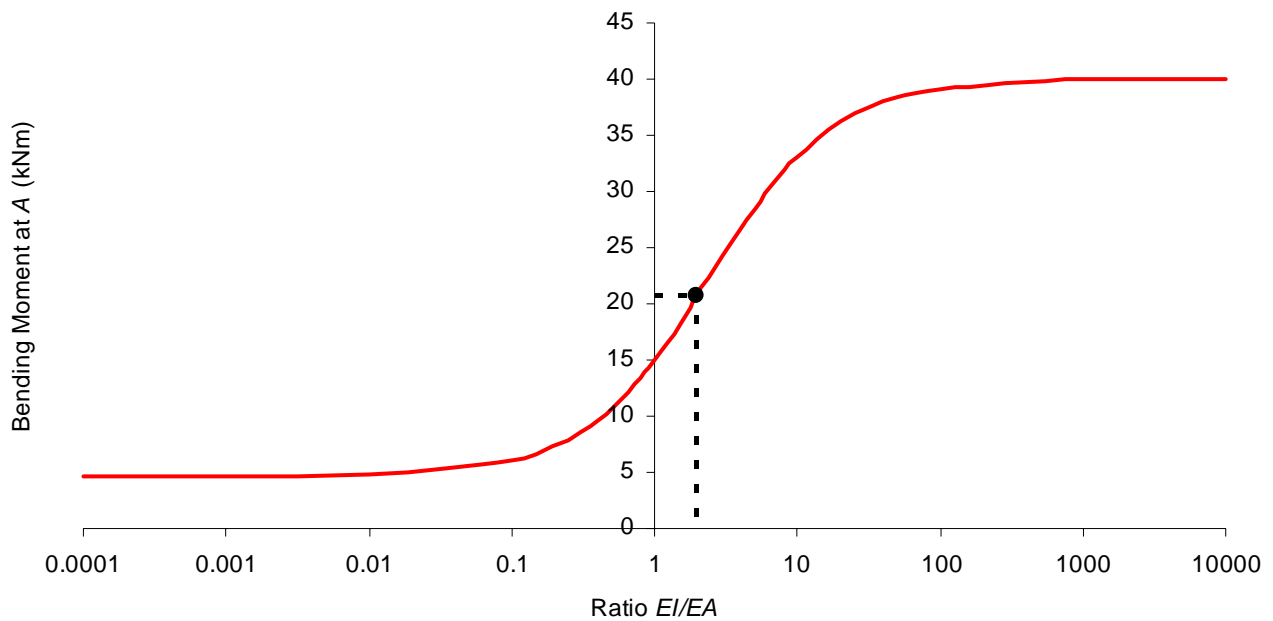

Deflections and shear would also be affected.

Draw the final BMD and determine the deflection at D .

3.5 Further Examples

To be done in class or given out in handout.

4. Exercises

4.1 Problems

Problem 1

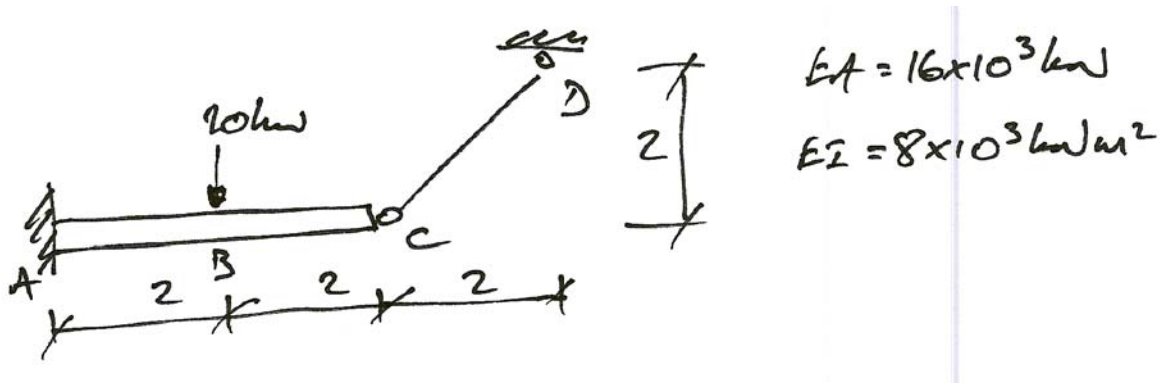

Find the BMD and the vertical deflection at C.

(Ans. $\alpha = 7.8$ for CD , $\delta_{Cv} = 1.93 \text{ mm} \downarrow$)

Problem 2

Problem 3

Problem 4

4.2 Past Exam Questions

Sample Paper 2007

3. For the rigidly jointed frame shown in Fig. Q3, using Virtual Work:
- (i) Determine the bending moment moments due to the loads as shown; (15 marks)
 - (ii) Draw the bending moment diagram, showing all important values; (4 marks)
 - (iii) Determine the reactions at *A* and *E*; (3 marks)
 - (iv) Draw the deflected shape of the frame. (3 marks)

Neglect axial effects in the flexural members.
 Take the following values:
 I for the frame = $150 \times 10^6 \text{ mm}^4$;
 Area of the stay $EB = 100 \text{ mm}^2$;
 Take $E = 200 \text{ kN/mm}^2$ for all members.

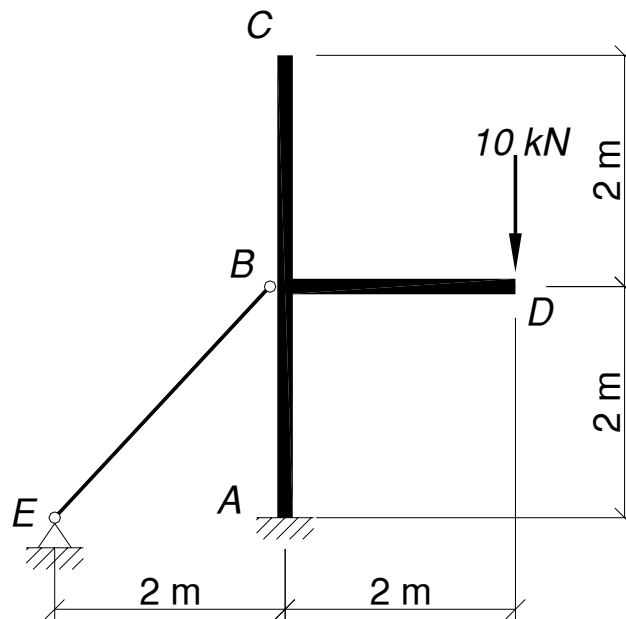

FIG. Q3

Semester 1 Exam 2007

3. For the rigidly jointed frame shown in Fig. Q3, using Virtual Work:

- (i) Determine the bending moment moments due to the loads as shown; (15 marks)
- (ii) Draw the bending moment diagram, showing all important values; (4 marks)
- (iii) Determine the reactions at A and E; (3 marks)
- (iv) Draw the deflected shape of the frame. (3 marks)

Neglect axial effects in the flexural members.
 Take the following values:
 I for the frame = $150 \times 10^6 \text{ mm}^4$;
 Area of the stay $EF = 200 \text{ mm}^2$;
 Take $E = 200 \text{ kN/mm}^2$ for all members.

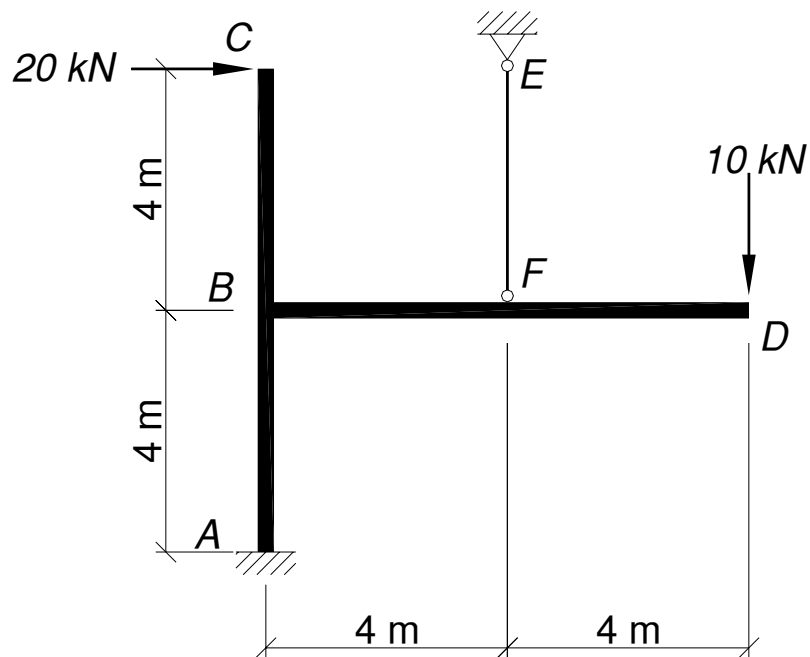

FIG. Q3

Ans. $\alpha = 35.0$.

Semester 1 Exam 2008

QUESTION 3

For the frame shown in Fig. Q3, using Virtual Work:

- (i) Determine the force in the tie;
- (ii) Draw the bending moment diagram, showing all important values;
- (iii) Determine the deflection at *C*;
- (iv) Determine an area of the tie such that the bending moments in the beam are minimized;
- (v) For this new area of tie, determine the deflection at *C*;
- (vi) Draw the deflected shape of the structure.

(25 marks)

Note:

Neglect axial effects in the flexural members and take the following values:

- For the frame, $I = 600 \times 10^6 \text{ mm}^4$;
- For the tie, $A = 300 \text{ mm}^2$;
- For all members, $E = 200 \text{ kN/mm}^2$.

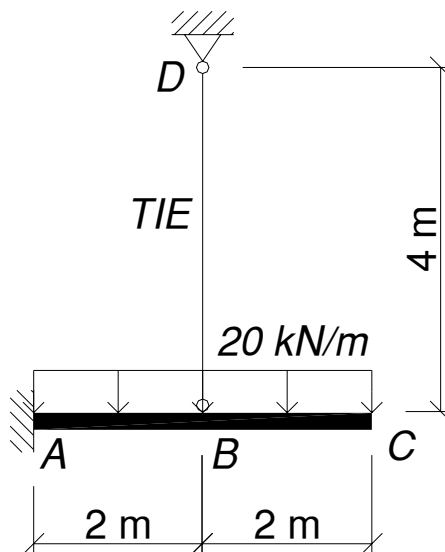

FIG. Q3

Ans. $\alpha = 21.24$; $\delta_{Cy} = 4.1 \text{ mm} \downarrow$; $A = 2160 \text{ mm}^2$; $\delta_{Cy} = 2.0 \text{ mm} \downarrow$

Semester 1 Exam 2009

QUESTION 3

For the frame shown in Fig. Q3, using Virtual Work:

- (i) Determine the axial forces in the members;
- (ii) Draw the bending moment diagram, showing all important values;
- (iii) Determine the reactions;
- (iv) Determine the vertical deflection at D ;
- (v) Draw the deflected shape of the structure.

(25 marks)

Note:

Neglect axial effects in the flexural members and take the following values:

- For the beam $ABCD$, $I = 600 \times 10^6 \text{ mm}^4$;
- For members BF and CE , $A = 300 \text{ mm}^2$;
- For all members, $E = 200 \text{ kN/mm}^2$.

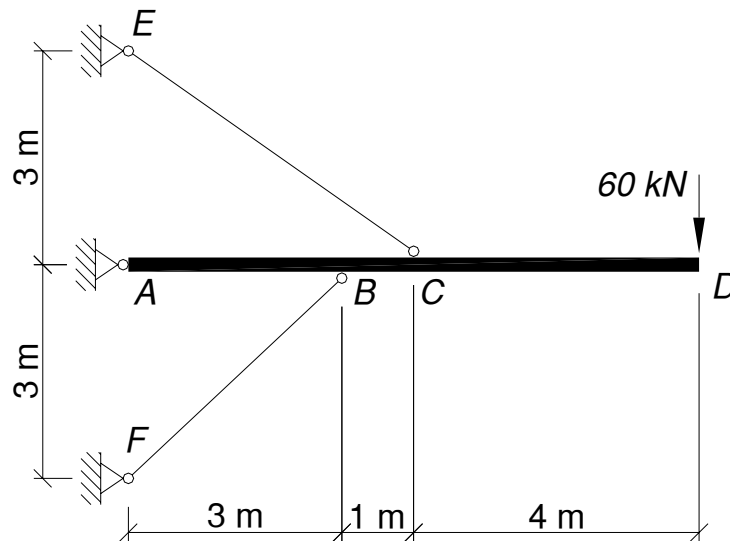

FIG. Q3

Ans. $\alpha = 113.7$ (for CE); $\delta_{Dy} = 55 \text{ mm} \downarrow$

5. Appendix – Trigonometric Integrals

5.1 Useful Identities

In the following derivations, use is made of the trigonometric identities:

$$\cos \theta \sin \theta = \frac{1}{2} \sin 2\theta \quad (1.1)$$

$$\cos^2 \theta = \frac{1}{2}(1 + \cos 2\theta) \quad (1.2)$$

$$\sin^2 \theta = \frac{1}{2}(1 - \cos 2\theta) \quad (1.3)$$

Integration by parts is also used:

$$\int u \, dx = ux - \int x \, du + C \quad (1.4)$$

5.2 Basic Results

Neglecting the constant of integration, some useful results are:

$$\int \cos \theta d\theta = \sin \theta \quad (2.1)$$

$$\int \sin \theta d\theta = -\cos \theta \quad (2.2)$$

$$\int \sin a\theta d\theta = -\frac{1}{a} \cos a\theta \quad (2.3)$$

$$\int \cos a\theta d\theta = \frac{1}{a} \sin a\theta \quad (2.4)$$

5.3 Common Integrals

The more involved integrals commonly appearing in structural analysis problems are:

$$\int \cos \theta \sin \theta d\theta$$

Using identity (1.1) gives:

$$\int \cos \theta \sin \theta d\theta = \frac{1}{2} \int \sin 2\theta d\theta$$

Next using (2.3), we have:

$$\begin{aligned} \frac{1}{2} \int \sin 2\theta d\theta &= \frac{1}{2} \left[-\frac{1}{2} \cos 2\theta \right] \\ &= -\frac{1}{4} \cos 2\theta \end{aligned}$$

And so:

$$\int \cos \theta \sin \theta d\theta = -\frac{1}{4} \cos 2\theta \quad (3.1)$$

$$\int \cos^2 \theta d\theta$$

Using (1.2), we have:

$$\begin{aligned}\int \cos^2 \theta d\theta &= \frac{1}{2} \int (1 + \cos 2\theta) d\theta \\ &= \frac{1}{2} \left[\int 1 d\theta + \int \cos 2\theta d\theta \right]\end{aligned}$$

Next using (2.4):

$$\begin{aligned}\frac{1}{2} \left[\int 1 d\theta + \int \cos 2\theta d\theta \right] &= \frac{1}{2} \left[\theta + \frac{1}{2} \sin 2\theta \right] \\ &= \frac{\theta}{2} + \frac{1}{4} \sin 2\theta\end{aligned}$$

And so:

$$\int \cos^2 \theta d\theta = \frac{\theta}{2} + \frac{1}{4} \sin 2\theta \quad (3.2)$$

$$\int \sin^2 \theta d\theta$$

Using (1.3), we have:

$$\begin{aligned}\int \sin^2 \theta d\theta &= \frac{1}{2} \int (1 - \cos 2\theta) d\theta \\ &= \frac{1}{2} \left[\int 1 d\theta - \int \cos 2\theta d\theta \right]\end{aligned}$$

Next using (2.4):

$$\begin{aligned}\frac{1}{2} \left[\int 1 d\theta - \int \cos 2\theta d\theta \right] &= \frac{1}{2} \left[\theta - \frac{1}{2} \sin 2\theta \right] \\ &= \frac{\theta}{2} - \frac{1}{4} \sin 2\theta\end{aligned}$$

And so:

$$\int \sin^2 \theta d\theta = \frac{\theta}{2} - \frac{1}{4} \sin 2\theta \quad (3.3)$$

$$\int \theta \cos \theta d\theta$$

Using integration by parts write:

$$\int \theta \cos \theta d\theta = \int u dx$$

Where:

$$u = \theta \quad dx = \cos \theta d\theta$$

To give:

$$du = d\theta$$

And

$$\int dx = \int \cos \theta d\theta$$
$$x = \sin \theta$$

Which uses (2.1). Thus, from (1.4), we have:

$$\int u dx = ux - \int x du$$
$$\int \theta \cos \theta d\theta = \theta \sin \theta - \int \sin \theta d\theta$$

And so, using (2.2) we have:

$$\int \theta \cos \theta d\theta = \theta \sin \theta + \cos \theta \quad (3.4)$$

$$\int \theta \sin \theta d\theta$$

Using integration by parts write:

$$\int \theta \sin \theta d\theta = \int u dx$$

Where:

$$u = \theta \quad dx = \sin \theta d\theta$$

To give:

$$du = d\theta$$

And

$$\int dx = \int \sin \theta d\theta$$
$$x = -\cos \theta$$

Which uses (2.2). Thus, from (1.4), we have:

$$\int u dx = ux - \int x du$$
$$\int \theta \sin \theta d\theta = \theta(-\cos \theta) - \int (-\cos \theta) d\theta$$

And so, using (2.1) we have:

$$\int \theta \sin \theta d\theta = -\theta \cos \theta + \sin \theta \quad (3.5)$$

$$\int \cos(A - \theta) d\theta$$

Using integration by substitution, we write $u = A - \theta$ to give:

$$\begin{aligned}\frac{du}{d\theta} &= -1 \\ du &= -d\theta\end{aligned}$$

Thus:

$$\int \cos(A - \theta) d\theta = \int \cos u (-du)$$

And since, using (2.1):

$$-\int \cos u du = -\sin u$$

We have:

$$\int \cos(A - \theta) d\theta = -\sin(A - \theta) \quad (3.6)$$

$$\int \sin(A - \theta) d\theta$$

Using integration by substitution, we write $u = A - \theta$ to give:

$$\begin{aligned}\frac{du}{d\theta} &= -1 \\ du &= -d\theta\end{aligned}$$

Thus:

$$\int \sin(A - \theta) d\theta = \int \sin u (-du)$$



And since, using (2.2):

$$-\int \sin u du = -(-\cos u)$$

We have:

$$\int \sin(A - \theta) d\theta = \cos(A - \theta) \tag{3.7}$$

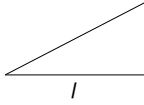
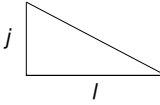
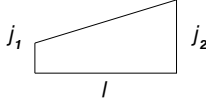
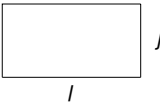
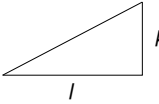
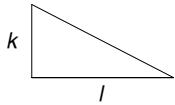
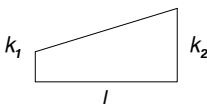
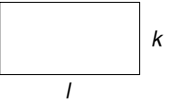
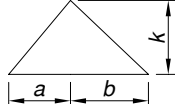
6. Appendix – Volume Integrals

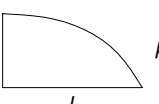
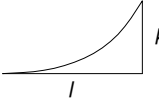
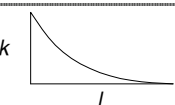
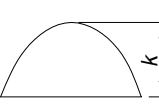
				
	$\frac{1}{3} jkl$	$\frac{1}{6} jkl$	$\frac{1}{6} (j_1 + 2j_2) kl$	$\frac{1}{2} jkl$
	$\frac{1}{6} jkl$	$\frac{1}{3} jkl$	$\frac{1}{6} (2j_1 + j_2) kl$	$\frac{1}{2} jkl$
	$\frac{1}{6} j(k_1 + 2k_2) l$	$\frac{1}{6} j(2k_1 + k_2) l$	$\frac{1}{6} [j_1(2k_1 + k_2) + j_2(k_1 + 2k_2)] l$	$\frac{1}{2} j(k_1 + k_2) l$
	$\frac{1}{2} jkl$	$\frac{1}{2} jkl$	$\frac{1}{2} (j_1 + j_2) kl$	jkl
	$\frac{1}{6} jk(l+a)$	$\frac{1}{6} jk(l+b)$	$\frac{1}{6} [j_1(l+b) + j_2(l+a)] k$	$\frac{1}{2} jkl$
	$\frac{5}{12} jkl$	$\frac{1}{4} jkl$	$\frac{1}{12} (3j_1 + 5j_2) kl$	$\frac{2}{3} jkl$
	$\frac{1}{4} jkl$	$\frac{5}{12} jkl$	$\frac{1}{12} (5j_1 + 3j_2) kl$	$\frac{2}{3} jkl$
	$\frac{1}{4} jkl$	$\frac{1}{12} jkl$	$\frac{1}{12} (j_1 + 3j_2) kl$	$\frac{1}{3} jkl$
	$\frac{1}{12} jkl$	$\frac{1}{4} jkl$	$\frac{1}{12} (3j_1 + j_2) kl$	$\frac{1}{3} jkl$
	$\frac{1}{3} jkl$	$\frac{1}{3} jkl$	$\frac{1}{3} (j_1 + j_2) kl$	$\frac{2}{3} jkl$

7. Ring Beam Examples (Advanced)

7.1 Example 1

Problem

For the quarter-circle beam shown, which has flexural and torsional rigidities of EI and GJ respectively, show that the deflection at A due to the point load, P , at A is:

$$\delta_{Ay} = \frac{PR^3}{EI} \cdot \frac{\pi}{4} + \frac{PR^3}{GJ} \left(\frac{3\pi - 8}{4} \right)$$

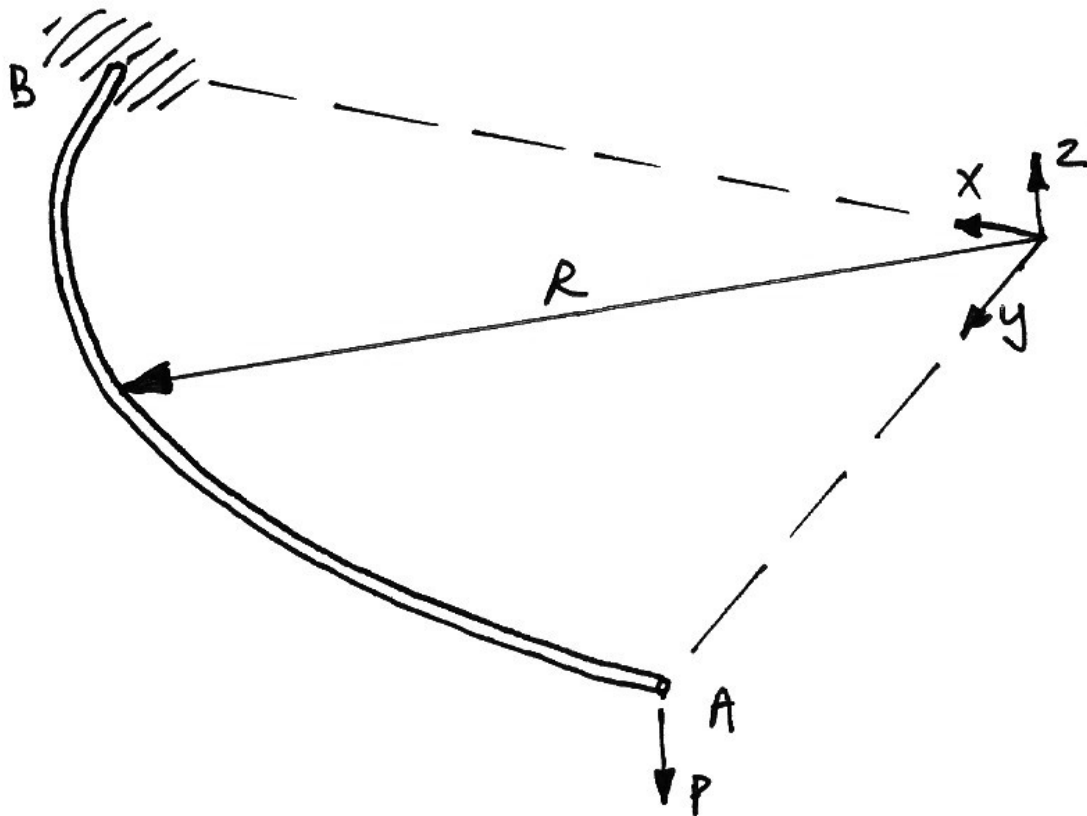

Solution

The point load will cause both bending and torsion in the beam member. Therefore both effects must be accounted for in the deflection calculations. Shear effects are ignored.

Drawing a plan view of the structure, we can identify the perpendicular distance of the force, P , from the section of consideration, which we locate by the angle θ from the y -axis:

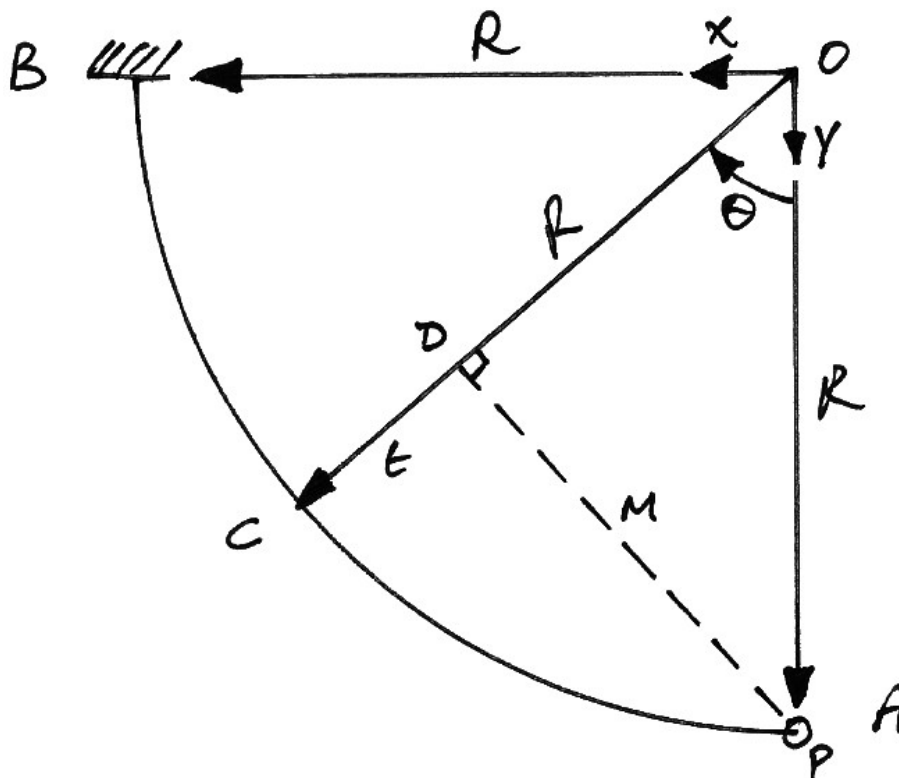

The bending moment at C is P times the perpendicular distance $|AC|$, called m . The torsion at C is the force times the transverse perpendicular distance $|CD|$, called t . Using the triangle ODA , we have:

$$\sin \theta = \frac{m}{R} \quad \therefore m = R \sin \theta$$

$$\cos \theta = \frac{|OD|}{R} \quad \therefore |OD| = R \cos \theta$$

The distance $|CD|$, or t , is $R - |OD|$, thus:

$$\begin{aligned} t &= R - |OD| \\ &= R - R \cos \theta \\ &= R(1 - \cos \theta) \end{aligned}$$

Thus the bending moment at point C is:

$$\begin{aligned} M(\theta) &= Pm \\ &= PR \sin \theta \end{aligned} \quad (1.1)$$

The torsion at C is:

$$\begin{aligned} T(\theta) &= Pt \\ &= PR(1 - \cos \theta) \end{aligned} \quad (1.2)$$

Using virtual work, we have:

$$\begin{aligned} \delta W &= 0 \\ \delta W_E &= \delta W_I \\ \delta_{A_y} \cdot \delta F &= \int \frac{M}{EI} \cdot \delta M \, ds + \int \frac{T}{GJ} \cdot \delta T \, ds \end{aligned} \quad (1.3)$$

This equation represents the virtual work done by the application of a virtual force, δF , in the vertical direction at A , with its internal equilibrium virtual moments and torques, δM and δT and so is the equilibrium system. The compatible displacements system is that of the actual deformations of the structure, externally at A , and internally by the curvatures and twists, M/EI and T/GJ .

Taking the virtual force, $\delta F = 1$, and since it is applied at the same location and direction as the actual force P , we have, from equations (1.1) and (1.2):

$$\delta M(\theta) = R \sin \theta \quad (1.4)$$

$$\delta T(\theta) = R(1 - \cos \theta) \quad (1.5)$$

Thus, the virtual work equation, (1.3), becomes:

$$\begin{aligned} \delta_{Ay} \cdot 1 &= \frac{1}{EI} \int M \cdot \delta M \, ds + \frac{1}{GJ} \int T \cdot \delta T \, ds \\ &= \frac{1}{EI} \int_0^{\pi/2} [PR \sin \theta][R \sin \theta] R d\theta + \frac{1}{GJ} \int_0^{\pi/2} [PR(1 - \cos \theta)][R(1 - \cos \theta)] R d\theta \end{aligned} \quad (1.6)$$

In which we have related the curve distance, ds , to the arc distance, $ds = R d\theta$, which allows us to integrate round the angle rather than along the curve. Multiplying out:

$$\delta_{Ay} = \frac{PR^3}{EI} \int_0^{\pi/2} \sin^2 \theta \, d\theta + \frac{PR^3}{GJ} \int_0^{\pi/2} (1 - \cos \theta)^2 \, d\theta \quad (1.7)$$

Considering the first term, from the integrals' appendix, we have:

$$\begin{aligned}
 \int_0^{\pi/2} \sin^2 \theta \, d\theta &= \left[\frac{\theta}{2} - \frac{1}{4} \sin 2\theta \right]_0^{\pi/2} \\
 &= \left[\left(\frac{\pi}{4} - \frac{1}{4} \cdot 0 \right) - (0 - 0) \right] \\
 &= \frac{\pi}{4}
 \end{aligned} \tag{1.8}$$

The second term is:

$$\begin{aligned}
 \int_0^{\pi/2} (1 - \cos \theta)^2 \, d\theta &= \int_0^{\pi/2} (1 - 2\cos \theta + \cos^2 \theta) \, d\theta \\
 &= \int_0^{\pi/2} 1 \, d\theta - 2 \int_0^{\pi/2} \cos \theta \, d\theta + \int_0^{\pi/2} \cos^2 \theta \, d\theta
 \end{aligned} \tag{1.9}$$

Thus, from the integrals in the appendix:

$$\begin{aligned}
 \int_0^{\pi/2} (1 - \cos \theta)^2 \, d\theta &= [\theta]_0^{\pi/2} - 2[\sin \theta]_0^{\pi/2} + \left[\frac{\theta}{2} + \frac{1}{4} \sin 2\theta \right]_0^{\pi/2} \\
 &= \left[\left(\frac{\pi}{2} \right) - (0) \right] - 2[(1) - (0)] + \left[\left(\frac{\pi}{4} + \frac{1}{4} \cdot 0 \right) - (0 + 0) \right] \\
 &= \frac{\pi}{2} - 2 + \frac{\pi}{4} \\
 &= \frac{3\pi - 8}{4}
 \end{aligned} \tag{1.10}$$

Substituting these results back into equation (1.7) gives the desired result:

$$\delta_{Ay} = \frac{PR^3}{EI} \frac{\pi}{4} + \frac{PR^3}{GJ} \left(\frac{3\pi - 8}{4} \right) \tag{1.11}$$

7.2 Example 2**Problem**

For the quarter-circle beam shown, which has flexural and torsional rigidities of EI and GJ respectively, show that the deflection at A due to the uniformly distributed load, w , shown is:

$$\delta_{Ay} = \frac{wR^4}{EI} \cdot \frac{1}{2} + \frac{wR^4}{GJ} \cdot \frac{(\pi - 2)^2}{8}$$

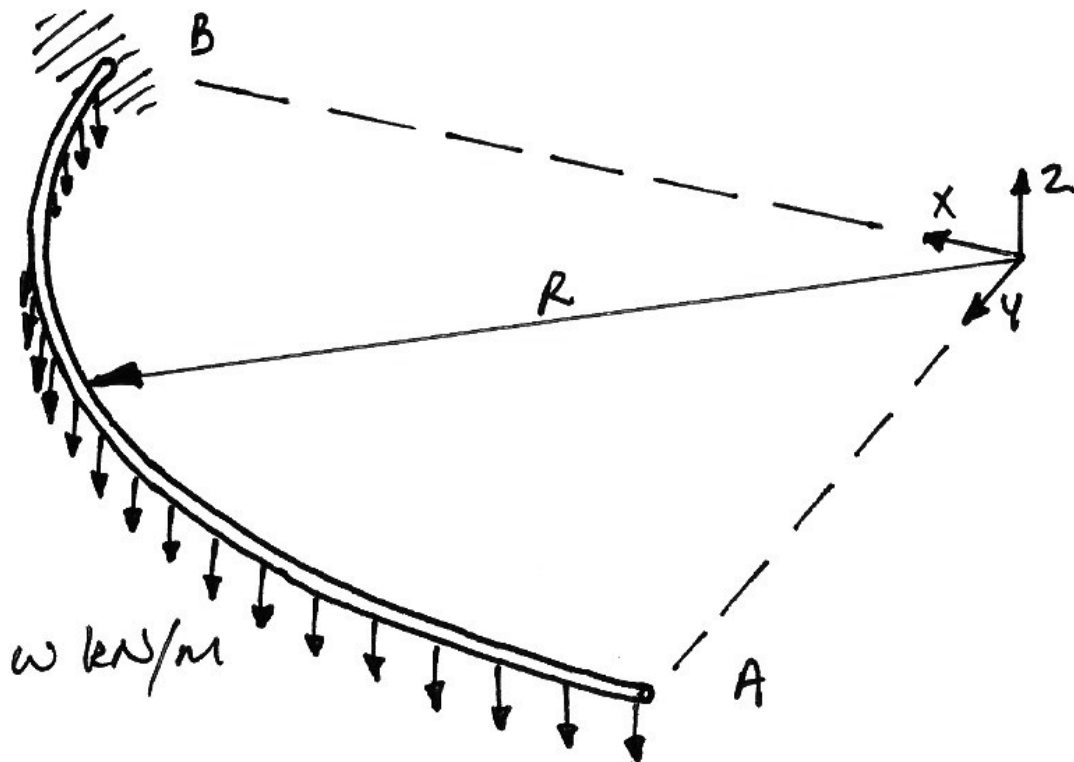

Solution

The UDL will cause both bending and torsion in the beam member and both effects must be accounted for. Again, shear effects are ignored.

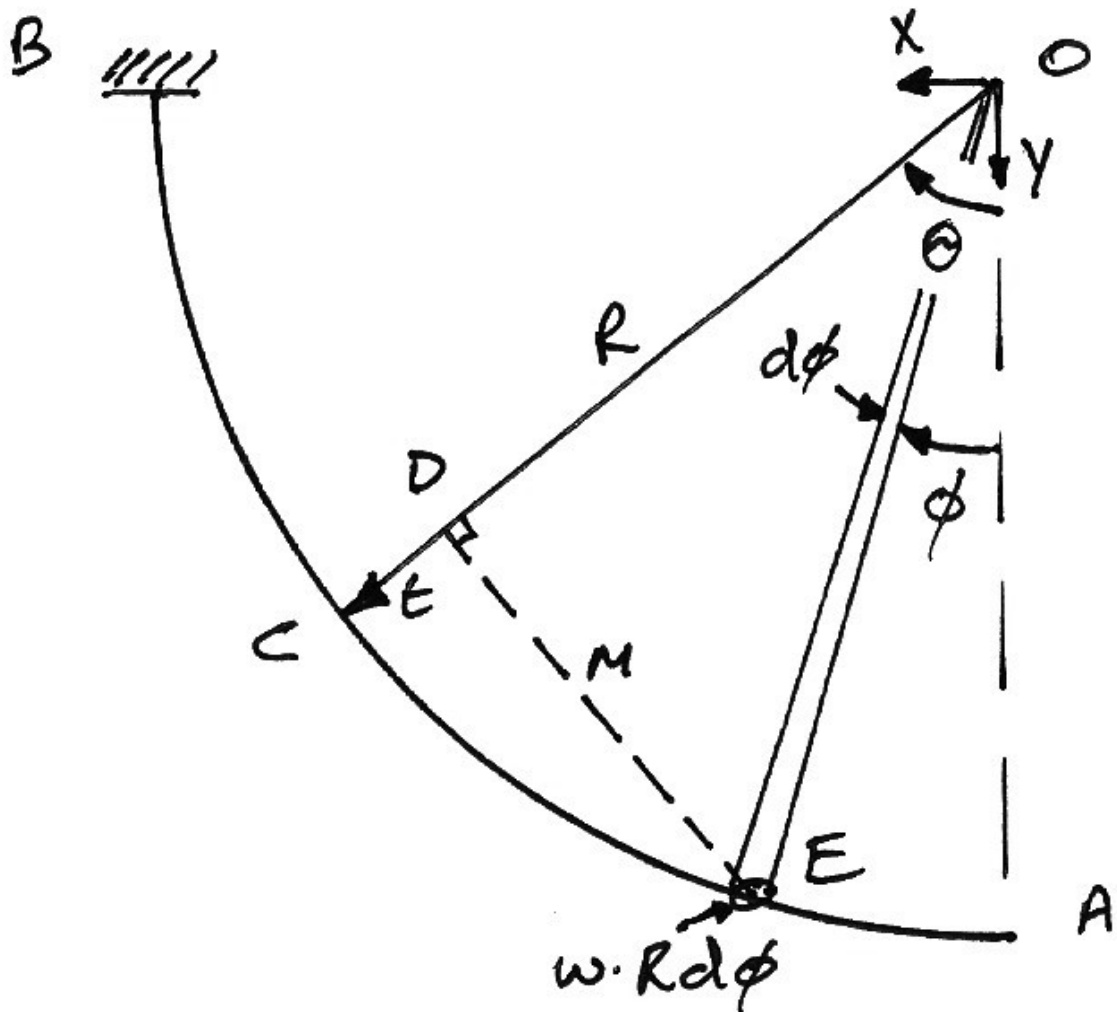

Drawing a plan view of the structure, we must identify the moment and torsion at some point C , as defined by the angle θ from the y -axis, caused by the elemental load at E , located at ϕ from the y -axis. The load is given by:

$$\begin{aligned}
 \text{Force} &= \text{UDL} \times \text{length} \\
 &= w \cdot ds \\
 &= w \cdot R d\phi
 \end{aligned}
 \tag{2.1}$$

The bending moment at C is the load at E times the perpendicular distance $|DE|$, labelled m . The torsion at C is the force times the transverse perpendicular distance $|CD|$, labelled t . Using the triangle ODE , we have:

$$\begin{aligned}\sin(\theta - \phi) &= \frac{m}{R} & \therefore m &= R \sin(\theta - \phi) \\ \cos(\theta - \phi) &= \frac{|OD|}{R} & \therefore |OD| &= R \cos(\theta - \phi)\end{aligned}$$

The distance t is thus:

$$\begin{aligned}t &= R - |OD| \\ &= R - R \cos(\theta - \phi) \\ &= R[1 - \cos(\theta - \phi)]\end{aligned}$$

The differential bending moment at point C , caused by the elemental load at E is thus:

$$\begin{aligned}dM(\theta) &= \text{Force} \times \text{Distance} \\ &= [wRd\phi] \times m \\ &= [wRd\phi][R \sin(\theta - \phi)] \\ &= wR^2 \sin(\theta - \phi) d\phi\end{aligned}$$

Integrating to find the total moment at C caused by the UDL from A to C around the angle 0 to θ gives:

$$\begin{aligned}
 M(\theta) &= \int dM(\theta) \\
 &= \int_{\phi=0}^{\phi=\theta} wR^2 \sin(\theta - \phi) d\phi \\
 &= wR^2 \int_{\phi=0}^{\phi=\theta} \sin(\theta - \phi) d\phi
 \end{aligned}$$

In this integral θ is a constant and only ϕ is considered a variable. Using the identity from the integral table gives:

$$\begin{aligned}
 M(\theta) &= wR^2 \left[\cos(\theta - \phi) \right]_{\phi=0}^{\phi=\theta} \\
 &= wR^2 \left[(\cos 0) - \cos \theta \right]
 \end{aligned}$$

And so:

$$M(\theta) = wR^2(1 - \cos \theta) \quad (2.2)$$

Along similar lines, the torsion at C caused by the load at E is:

$$\begin{aligned}
 dT(\theta) &= [wRd\phi] \times t \\
 &= [wRd\phi] \{ R[1 - \cos(\theta - \phi)] \} \\
 &= wR^2 [1 - \cos(\theta - \phi)] d\phi
 \end{aligned}$$

And integrating for the total torsion at C :

$$\begin{aligned}
 T(\theta) &= \int dT(\theta) \\
 &= \int_{\phi=0}^{\phi=\theta} wR^2 [1 - \cos(\theta - \phi)] d\phi \\
 &= wR^2 \int_{\phi=0}^{\phi=\theta} [1 - \cos(\theta - \phi)] d\phi \\
 &= wR^2 \left\{ \int_{\phi=0}^{\phi=\theta} 1 d\phi - \int_{\phi=0}^{\phi=\theta} \cos(\theta - \phi) d\phi \right\}
 \end{aligned}$$

Using the integral identity for $\cos(\theta - \phi)$ gives:

$$\begin{aligned}
 T(\theta) &= wR^2 \left\{ [\phi]_{\phi=0}^{\phi=\theta} - [-\sin(\theta - \phi)]_{\phi=0}^{\phi=\theta} \right\} \\
 &= wR^2 \left\{ \theta + [\sin 0 - \sin \theta] \right\}
 \end{aligned}$$

And so the total torsion at C is:

$$T(\theta) = wR^2 (\theta - \sin \theta) \quad (2.3)$$

To determine the deflection at A , we apply a virtual force, δF , in the vertical direction at A . Along with its internal equilibrium virtual moments and torques, δM and δT and this set forms the equilibrium system. The compatible displacements system is that of the actual deformations of the structure, externally at A , and internally by the curvatures and twists, M/EI and T/GJ . Therefore, using virtual work, we have:

$$\begin{aligned}
 \delta W &= 0 \\
 \delta W_E &= \delta W_I \quad (2.4) \\
 \delta_{Ay} \cdot \delta F &= \int \frac{M}{EI} \cdot \delta M ds + \int \frac{T}{GJ} \cdot \delta T ds
 \end{aligned}$$

Taking the virtual force, $\delta F = 1$, and using the equation for moment and torque at any angle θ from Example 1, we have:

$$\delta M(\theta) = R \sin \theta \quad (2.5)$$

$$\delta T(\theta) = R(1 - \cos \theta) \quad (2.6)$$

Thus, the virtual work equation, (2.4), using equations (2.2) and (2.3), becomes:

$$\begin{aligned} \delta_{Ay} \cdot 1 &= \frac{1}{EI} \int M \cdot \delta M \, ds + \frac{1}{GJ} \int T \cdot \delta T \, ds \\ &= \frac{1}{EI} \int_0^{\pi/2} [wR^2(1 - \cos \theta)] [R \sin \theta] R d\theta \\ &\quad + \frac{1}{GJ} \int_0^{\pi/2} [wR^2(\theta - \sin \theta)] [R(1 - \cos \theta)] R d\theta \end{aligned} \quad (2.7)$$

In which we have related the curve distance, ds , to the arc distance, $ds = R d\theta$ allowing us to integrate round the angle rather than along the curve. Multiplying out:

$$\begin{aligned} \delta_{Ay} &= \frac{wR^4}{EI} \int_0^{\pi/2} (\sin \theta - \sin \theta \cos \theta) d\theta \\ &\quad + \frac{wR^4}{GJ} \int_0^{\pi/2} (\theta - \sin \theta - \theta \cos \theta + \cos \theta \sin \theta) d\theta \end{aligned} \quad (2.8)$$

Using the respective integrals from the appendix yields:

$$\begin{aligned}
 \delta_{Ay} &= \frac{wR^4}{EI} \left[-\cos \theta + \frac{1}{4} \cos 2\theta \right]_0^{\pi/2} \\
 &\quad + \frac{wR^4}{GJ} \left[\frac{\theta^2}{2} + \cos \theta - (\theta \sin \theta + \cos \theta) - \frac{1}{4} \cos 2\theta \right]_0^{\pi/2} \\
 &= \frac{wR^4}{EI} \left[\left(-0 - \frac{1}{4} \right) - \left(-1 + \frac{1}{4} \right) \right] \\
 &\quad + \frac{wR^4}{GJ} \left[\left(\frac{\pi^2}{8} + 0 - \left(\frac{\pi}{2} \cdot 1 + 0 \right) - \frac{1}{4}(-1) \right) - \left(0 + 1 - (0 + 1) - \frac{1}{4} \right) \right] \\
 &= \frac{wR^4}{EI} \left[\frac{1}{2} \right] \\
 &\quad + \frac{wR^4}{GJ} \left[\frac{\pi^2}{8} - \frac{\pi}{2} + \frac{1}{4} + \frac{1}{4} \right]
 \end{aligned}$$

Writing the second term as a common fraction:

$$\delta_{Ay} = \frac{wR^4}{EI} \cdot \frac{1}{2} + \frac{wR^4}{GJ} \left(\frac{\pi^2 - 4\pi + 4}{8} \right)$$

And then factorising, gives the required deflection at A:

$$\delta_{Ay} = \frac{wR^4}{EI} \cdot \frac{1}{2} + \frac{wR^4}{GJ} \cdot \frac{(\pi^2 - 2)^2}{8} \tag{2.9}$$

7.3 Example 3

Problem

For the quarter-circle beam shown, which has flexural and torsional rigidities of EI and GJ respectively, show that the vertical reaction at A due to the uniformly distributed load, w , shown is:

$$V_A = wR \left[\frac{4\beta + (\pi - 2)^2}{2\beta\pi + 2(3\pi - 8)} \right]$$

where $\beta = \frac{GJ}{EI}$.

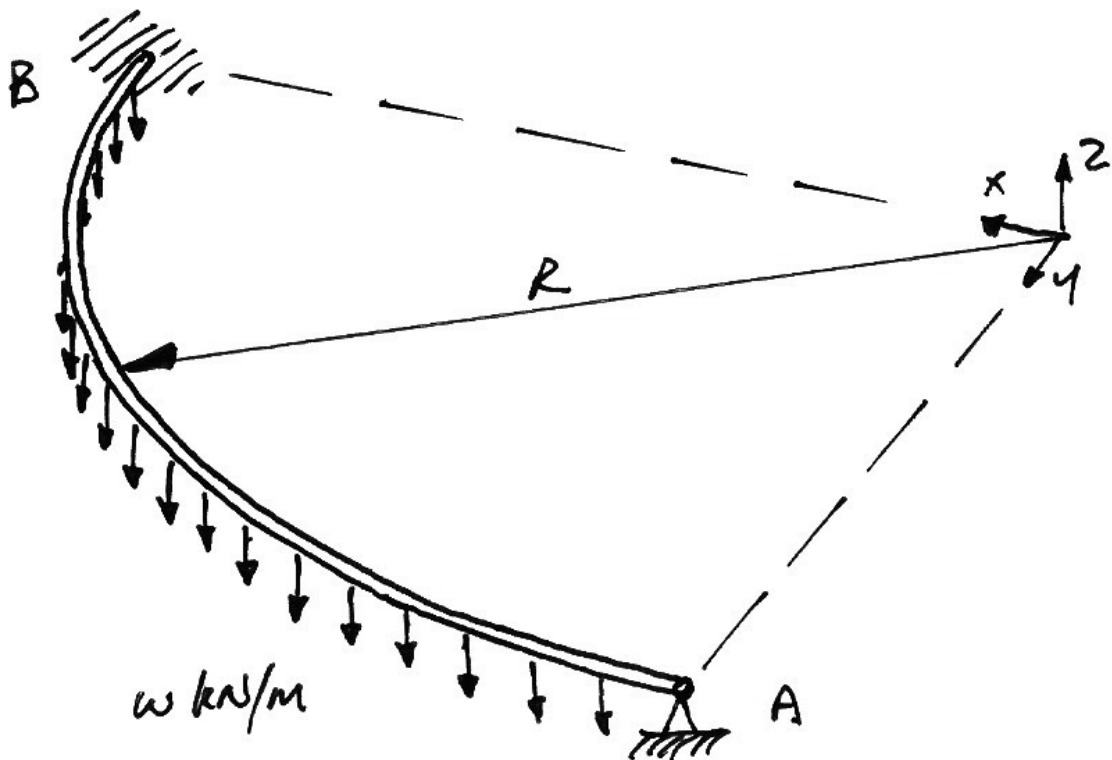

Solution

This problem can be solved using two apparently different methods, but which are equivalent. Indeed, examining how they are equivalent leads to insights that make more difficult problems easier, as we shall see in subsequent problems. For both approaches we will make use of the results obtained thus far:

- Deflection at A due to UDL:

$$\delta_{Ay} = \frac{wR^4}{EI} \cdot \frac{1}{2} + \frac{wR^4}{GJ} \cdot \frac{(\pi - 2)^2}{8} \quad (3.1)$$

- Deflection at A due to point load at A:

$$\delta_{Ay} = \frac{PR^3}{EI} \cdot \frac{\pi}{4} + \frac{PR^3}{GJ} \left(\frac{3\pi - 8}{4} \right) \quad (3.2)$$

Using Compatibility of Displacement

The basic approach, which does not require virtual work, is to use compatibility of displacement in conjunction with superposition. If we imagine the support at A removed, we will have a downwards deflection at A caused by the UDL, which equation (3.1) gives us as:

$$\delta_{Ay}^0 = \frac{wR^4}{EI} \cdot \frac{1}{2} + \frac{wR^4}{GJ} \cdot \frac{(\pi - 2)^2}{8} \quad (3.3)$$

As illustrated in the following diagram.

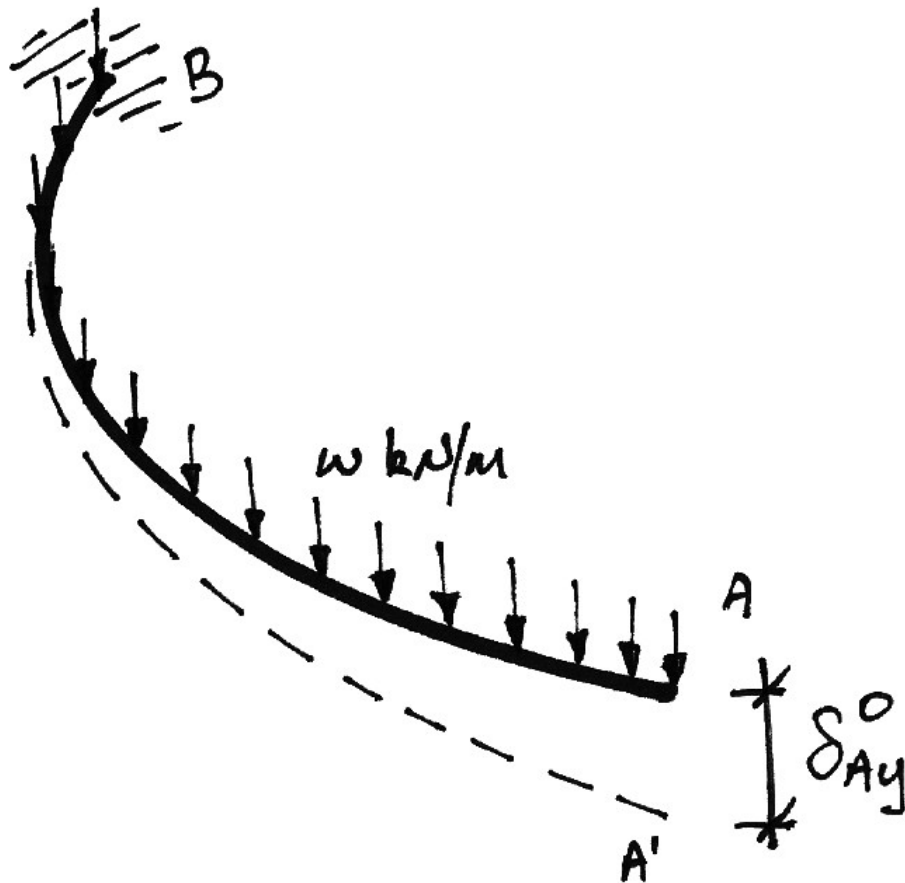

Since in the original structure we will have a support at A we know there is actually no displacement at A. The vertical reaction associated with the support at A, called V, must therefore be such that it causes an exactly equal and opposite deflection, δ_{Ay}^V , to that of the UDL, δ_{Ay}^0 , so that we are left with no deflection at A:

$$\delta_{Ay}^0 + \delta_{Ay}^V = 0 \tag{3.4}$$

Of course we don't yet know the value of V, but from equation (3.2), we know the deflection caused by a unit load placed in lieu of V:

$$\delta_{Ay}^1 = \frac{1 \cdot R^3}{EI} \cdot \frac{\pi}{4} + \frac{1 \cdot R^3}{GJ} \left(\frac{3\pi - 8}{4} \right) \tag{3.5}$$

This is shown in the following diagram:

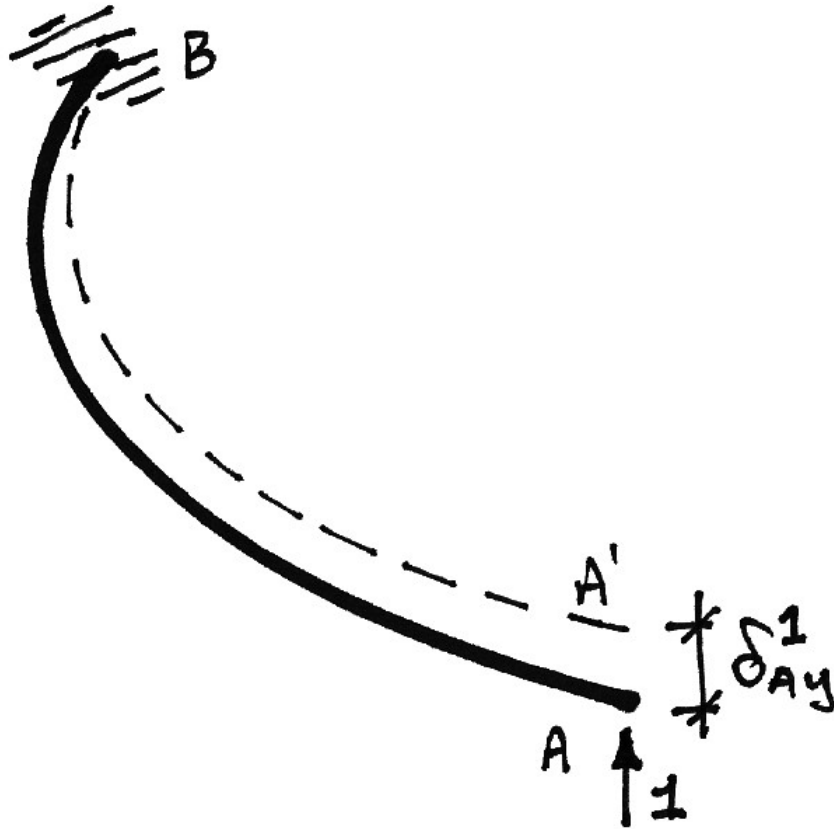

Using superposition, we know that the deflection caused by the reaction, V , is V times the deflection caused by a unit load:

$$\delta_{Ay}^V = V \cdot \delta_{Ay}^1 \quad (3.6)$$

Thus equation (3.4) becomes:

$$\delta_{Ay}^0 + V \cdot \delta_{Ay}^1 = 0 \quad (3.7)$$

Which we can solve for V :

$$V = -\frac{\delta_{Ay}^0}{\delta_{Ay}^1} \quad (3.8)$$

If we take downwards deflections to be positive, we then have, from equations(3.3), (3.5), and (3.8):

$$V = -\frac{\left(\frac{wR^4}{EI} \cdot \frac{1}{2} + \frac{wR^4}{GJ} \cdot \frac{(\pi-2)^2}{8}\right)}{-\left[\frac{1 \cdot R^3}{EI} \cdot \frac{\pi}{4} + \frac{1 \cdot R^3}{GJ} \left(\frac{3\pi-8}{4}\right)\right]} \quad (3.9)$$

The two negative signs cancel, leaving us with a positive value for V indicating that it is in the same direction as the unit load, and so is upwards as expected. Introducing

$\beta = \frac{GJ}{EI}$ and doing some algebra on equation (3.9) gives:

$$\begin{aligned} V &= wR \left(\frac{1}{EI} \cdot \frac{1}{2} + \frac{1}{\beta EI} \cdot \frac{(\pi-2)^2}{8} \right) \times \left[\frac{1}{EI} \cdot \frac{\pi}{4} + \frac{1}{\beta EI} \left(\frac{3\pi-8}{4} \right) \right]^{-1} \\ &= wR \left(\frac{1}{2} + \frac{1}{\beta} \cdot \frac{(\pi-2)^2}{8} \right) \times \left[\frac{\pi}{4} + \frac{1}{\beta} \left(\frac{3\pi-8}{4} \right) \right]^{-1} \\ &= wR \left(\frac{4\beta + (\pi-2)^2}{8\beta} \right) \times \left[\frac{\beta\pi + (3\pi-8)}{4\beta} \right]^{-1} \\ &= wR \left(\frac{4\beta + (\pi-2)^2}{8\beta} \right) \times \left[\frac{8\beta}{2\beta\pi + 2(3\pi-8)} \right] \end{aligned}$$

And so we finally have the required reaction at A as:

$$V_A = wR \left(\frac{4\beta + (\pi - 2)^2}{2\beta\pi + 2(3\pi - 8)} \right) \quad (3.10)$$

Using Virtual Work

To calculate the reaction at A using virtual work, we use the following:

- Equilibrium system: the external and internal virtual forces corresponding to a unit virtual force applied in lieu of the required reaction;
- Compatible system: the real external and internal displacements of the original structure subject to the real applied loads.

Thus the virtual work equations are:

$$\begin{aligned} \delta W &= 0 \\ \delta W_E &= \delta W_I \\ \delta_{A_y} \cdot \delta F &= \int \kappa \cdot \delta M \, ds + \int \phi \cdot \delta T \, ds \end{aligned} \quad (3.11)$$

At this point we introduce some points:

- The real external deflection at A is zero: $\delta_{A_y} = 0$;
- The virtual force, $\delta F = 1$;
- The real curvatures can be expressed using the real bending moments, $\kappa = \frac{M}{EI}$;
- The real twists are expressed from the torque, $\phi = \frac{T}{GJ}$.

These combine to give, from equation (3.11):

$$0 \cdot 1 = \int_0^L \left[\frac{M}{EI} \right] \cdot \delta M \, ds + \int_0^L \left[\frac{T}{GJ} \right] \cdot \delta T \, ds \quad (3.12)$$

Next, we use superposition to express the real internal ‘forces’ as those due to the real loading applied to the primary structure plus a multiplier times those due to the unit virtual load applied in lieu of the reaction:

$$M = M^0 + \alpha M^1 \quad T = T^0 + \alpha T^1 \quad (3.13)$$

Notice that $\delta M = M^1$ and $\delta T = T^1$, but they are still written with separate notation to keep the ideas clear. Thus equation (3.12) becomes:

$$\begin{aligned} 0 &= \int_0^L \left[\frac{(M^0 + \alpha M^1)}{EI} \right] \cdot \delta M \, ds + \int_0^L \left[\frac{(T^0 + \alpha T^1)}{GJ} \right] \cdot \delta T \, ds \\ 0 &= \int_0^L \frac{M^0}{EI} \cdot \delta M \, ds + \alpha \cdot \int_0^L \frac{M^1}{EI} \cdot \delta M \, ds + \int_0^L \frac{T^0}{GJ} \cdot \delta T \, ds + \alpha \cdot \int_0^L \frac{T^1}{GJ} \cdot \delta T \, ds \end{aligned} \quad (3.14)$$

And so finally:

$$\alpha = - \frac{\left[\int_0^L \frac{M^0}{EI} \cdot \delta M \, ds + \int_0^L \frac{T^0}{GJ} \cdot \delta T \, ds \right]}{\left[\int_0^L \frac{M^1}{EI} \cdot \delta M \, ds + \int_0^L \frac{T^1}{GJ} \cdot \delta T \, ds \right]} \quad (3.15)$$

At this point we must note the similarity between equations (3.15) and (3.8). From equation (1.3), it is clear that the numerator in equation (3.15) is the deflection at A of the primary structure subject to the real loads. Further, from equation (2.4), the denominator in equation (3.15) is the deflection at A due to a unit (virtual) load at A.

Neglecting signs, and generalizing somewhat, we can arrive at an ‘empirical’ equation for the calculation of redundants:

$$\alpha = \frac{\delta \text{ due to actual loads}}{\delta \text{ due to unit redundant}} \left. \vphantom{\alpha} \right\} \begin{array}{l} \text{of primary structure along} \\ \text{line of action of redundant} \end{array} \quad (3.16)$$

Using this form we will quickly be able to determine the solutions to further ring-beam problems.

The solution for α follows directly from the previous examples:

- The numerator is determined as per Example 1;
- The denominator is determined as per Example 2, with $P = 1$.

Of course, these two steps give the results of equations (3.3) and (3.5) which were used in equation (3.8) to obtain equation (3.9), and leading to the solution, equation (3.10).

From this it can be seen that compatibility of displacement and virtual work are equivalent ways of looking at the problem. Also it is apparent that the virtual work framework inherently calculates the displacements required in a compatibility analysis. Lastly, equation (3.16) provides a means for quickly calculating the redundant for other arrangements of the structure from the existing solutions, as will be seen in the next example.

7.4 Example 4

Problem

For the structure shown, the quarter-circle beam has flexural and torsional rigidities of EI and GJ respectively and the cable has axial rigidity EA , show that the tension in the cable due to the uniformly distributed load, w , shown is:

$$T = wR \left[4\beta + (\pi - 2)^2 \right] \left[2\pi\beta + 2(3\pi - 8) + 8 \frac{\beta}{\gamma} \cdot \frac{L}{R^3} \right]^{-1}$$

where $\beta = \frac{GJ}{EI}$ and $\gamma = \frac{EA}{EI}$.

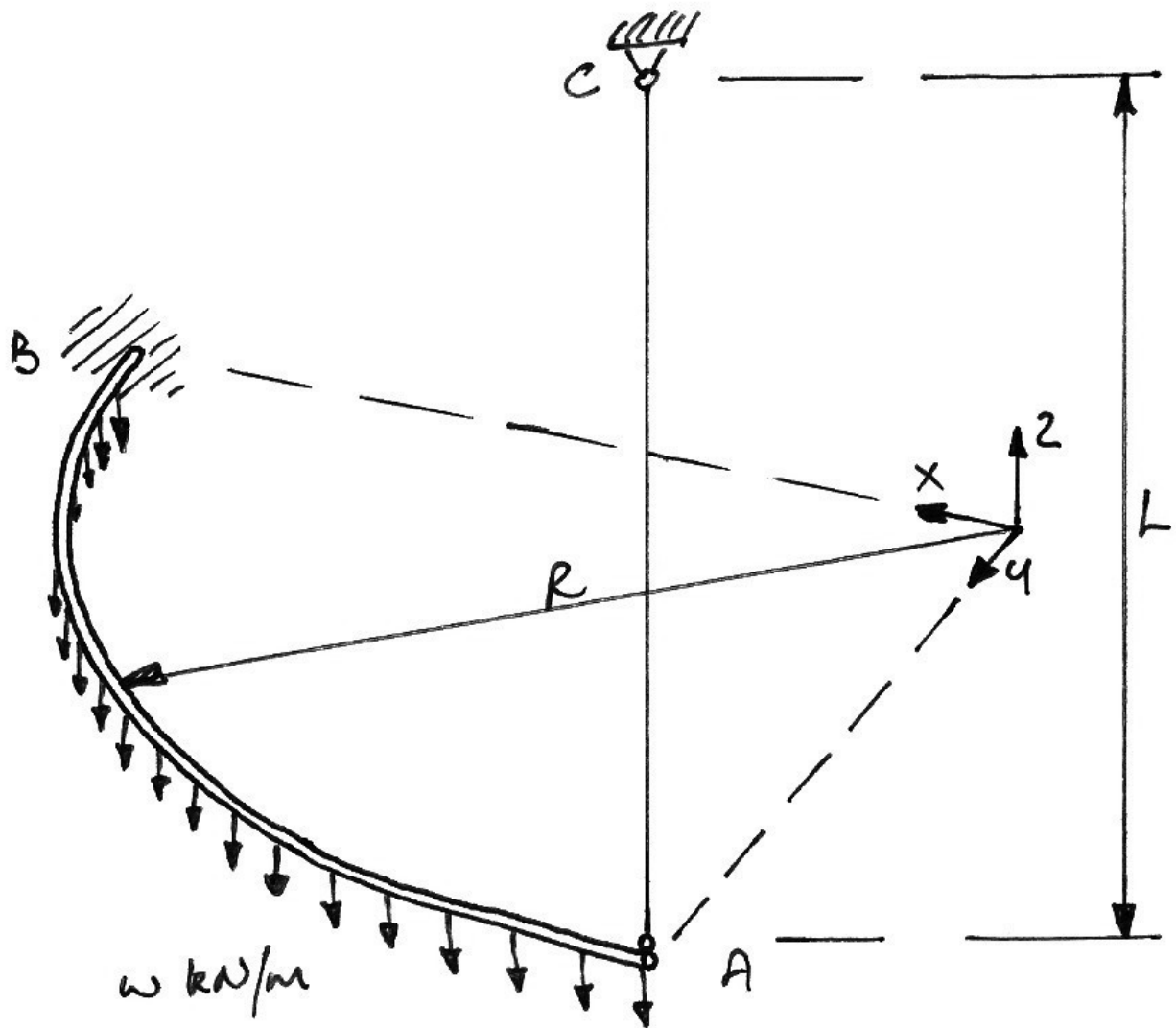

Solution

For this solution, we will use the insights gained from Example 3, in particular equation (3.16). We will then verify this approach using the usual application of virtual work. We will be choosing the cable as the redundant throughout.

Empirical Form

Repeating our ‘empirical’ equation here:

$$\alpha = \frac{\delta \text{ due to actual loads}}{\delta \text{ due to unit redundant}} \left. \vphantom{\alpha} \right\} \begin{array}{l} \text{of primary structure along} \\ \text{line of action of redundant} \end{array} \quad (4.1)$$

We see that we already know the numerator: the deflection at A in the primary structure, along the line of the redundant (vertical, since the cable is vertical), due to the actual loads on the structure is just the deflection of Example 1:

$$\delta_{Ay}^0 = \frac{wR^4}{EI} \cdot \frac{1}{2} + \frac{wR^4}{GJ} \cdot \frac{(\pi - 2)^2}{8} \quad (4.2)$$

This is shown below:

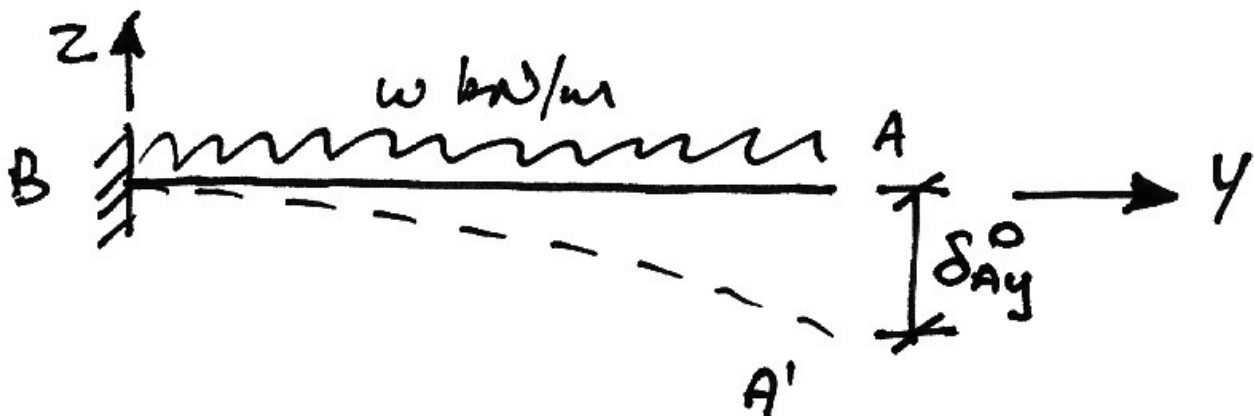

Next we need to identify the deflection of the primary structure due to a unit redundant, as shown below:

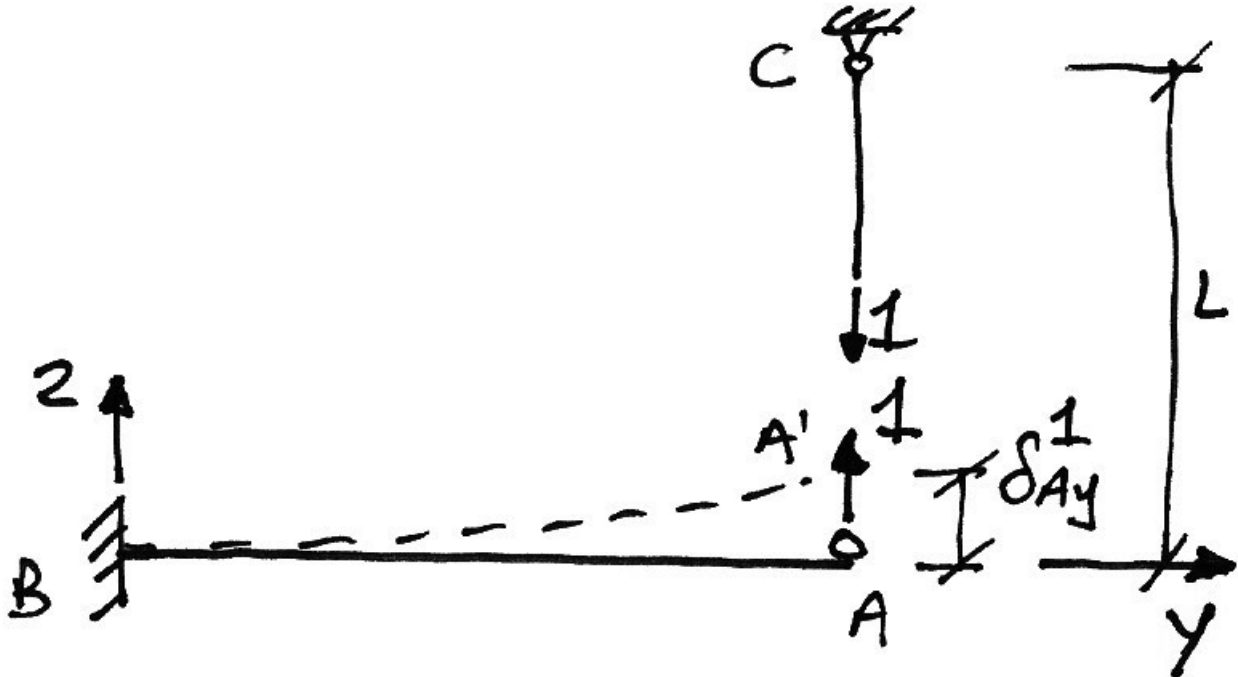

The components that make up this deflection are:

- Deflection of curved beam caused by unit load (bending and torsion);
- Deflection of the cable AC caused by the unit tension.

The first of these is simply the unit deflection of Example 3, equation (3.5):

$$\delta_{Ay}^1(\text{beam}) = \frac{1 \cdot R^3}{EI} \cdot \frac{\pi}{4} + \frac{1 \cdot R^3}{GJ} \left(\frac{3\pi - 8}{4} \right) \quad (4.3)$$

The second of these is not intuitive, but does feature in the virtual work equations, as we shall see. The elongation of the cable due to a unit tension is:

$$\delta_{Ay}^1 (\text{cable}) = \frac{1 \cdot L}{EA} \quad (4.4)$$

Thus the total deflection along the line of the redundant, of the primary structure, due to a unit redundant is:

$$\begin{aligned} \delta_{Ay}^1 &= \delta_{Ay}^1 (\text{beam}) + \delta_{Ay}^1 (\text{cable}) \\ &= \frac{1 \cdot R^3}{EI} \cdot \frac{\pi}{4} + \frac{1 \cdot R^3}{GJ} \left(\frac{3\pi - 8}{4} \right) + \frac{1 \cdot L}{EA} \end{aligned} \quad (4.5)$$

Both sets of deflections (equations (4.3) and (4.5)) are figuratively summarized as:

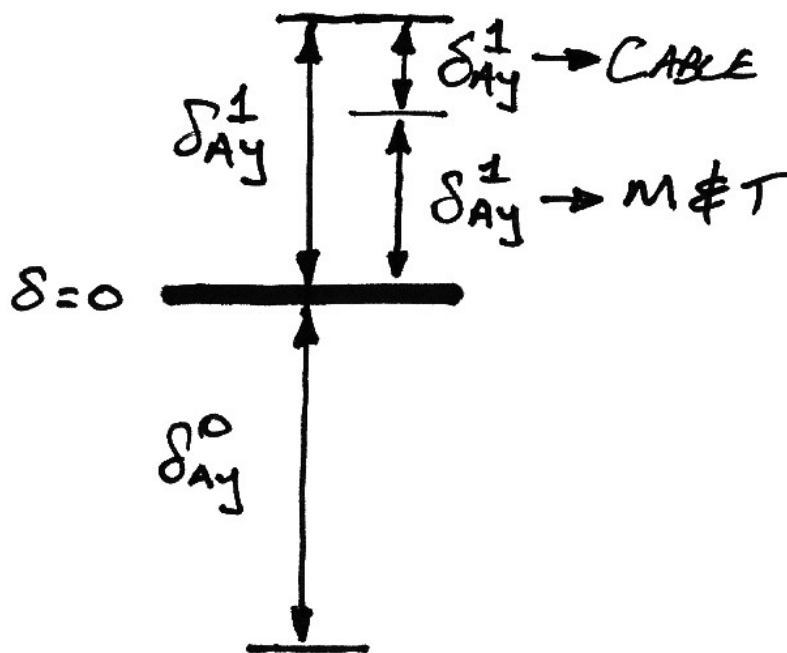

And by making $\delta_{Ay}^0 = T \delta_{Ay}^1$, where T is the tension in the cable, we obtain our compatibility equation for the redundant. Thus, from equations (4.1), (4.2) and (4.5) we have:

$$T = \frac{\left[\frac{wR^4}{EI} \cdot \frac{1}{2} + \frac{wR^4}{GJ} \cdot \frac{(\pi - 2)^2}{8} \right]}{\left[\frac{1 \cdot R^3}{EI} \cdot \frac{\pi}{4} + \frac{1 \cdot R^3}{GJ} \left(\frac{3\pi - 8}{4} \right) + \frac{1 \cdot L}{EA} \right]} \quad (4.6)$$

Setting $\beta = \frac{GJ}{EI}$ and $\gamma = \frac{EA}{EI}$, and performing some algebra gives:

$$\begin{aligned} T &= wR \left[\frac{1}{EI} \cdot \frac{1}{2} + \frac{1}{\beta EI} \cdot \frac{(\pi - 2)^2}{8} \right] \left[\frac{1}{EI} \cdot \frac{\pi}{4} + \frac{1}{\beta EI} \left(\frac{3\pi - 8}{4} \right) + \frac{L}{\gamma R^3 EI} \right]^{-1} \\ &= wR \left[\frac{4\beta + (\pi - 2)^2}{8\beta} \right] \left[\frac{\beta\pi + (3\pi - 8)}{4\beta} + \frac{L}{\gamma R^3} \right]^{-1} \\ &= wR \left[\frac{4\beta + (\pi - 2)^2}{8\beta} \right] \left[\frac{2\beta\pi + 2(3\pi - 8) + \frac{8\beta L}{\gamma R^3}}{8\beta} \right]^{-1} \end{aligned} \quad (4.7)$$

Which finally gives the required tension as:

$$T = wR \left[4\beta + (\pi - 2)^2 \right] \left[2\pi\beta + 2(3\pi - 8) + 8 \frac{\beta}{\gamma} \cdot \frac{L}{R^3} \right]^{-1} \quad (4.8)$$

Comparing this result to the previous result, equation (3.10), for a pinned support at A, we can see that the only difference is the term related to the cable: $8 \frac{\beta}{\gamma} \cdot \frac{L}{R^3}$. Thus

the ‘reaction’ (or tension in the cable) at A depends on the relative stiffnesses of the beam and cable (through the $\frac{R^3}{EI}$, $\frac{R^3}{GJ}$ and $\frac{L}{EA}$ terms inherent through γ and β).

This dependence on relative stiffness is to be expected.

Formal Virtual Work Approach

Without the use of the insight that equation (4.1) gives, the more formal application of virtual work will, of course, yield the same result. To calculate the tension in the cable using virtual work, we use the following:

- Equilibrium system: the external and internal virtual forces corresponding to a unit virtual force applied in lieu of the redundant;
- Compatible system: the real external and internal displacements of the original structure subject to the real applied loads.

Thus the virtual work equations are:

$$\begin{aligned} \delta W &= 0 \\ \delta W_E &= \delta W_I \\ \delta_{A_y} \cdot \delta F &= \int \kappa \cdot \delta M \, ds + \int \phi \cdot \delta T \, ds + \sum e \cdot \delta P \end{aligned} \quad (4.9)$$

In this equation we have accounted for all the major sources of displacement (and thus virtual work). At this point we acknowledge:

- There is no external virtual force applied, only an internal tension, thus $\delta F = 0$;
- The real curvatures and twists are expressed using the real bending moments and torques as $\kappa = \frac{M}{EI}$ and $\phi = \frac{T}{GJ}$ respectively;
- The elongation of the cable is the only source of axial displacement and is written in terms of the real tension in the cable, P , as $e = \frac{PL}{EA}$.

These combine to give, from equation (4.9):

$$\delta_{A_y} \cdot 0 = \int_0^L \left[\frac{M}{EI} \right] \cdot \delta M \, ds + \int_0^L \left[\frac{T}{GJ} \right] \cdot \delta T \, ds + \frac{PL}{EA} \cdot \delta P \quad (4.10)$$

As was done in Example 3, using superposition, we write:

$$M = M^0 + \alpha M^1 \quad T = T^0 + \alpha T^1 \quad P = P^0 + \alpha P^1 \quad (4.11)$$

However, we know that there is no tension in the cable in the primary structure, since it is the cable that is the redundant and is thus removed, hence $P^0 = 0$. Using this and equation (4.11) in equation (4.10) gives:

$$0 = \int_0^L \left[\frac{(M^0 + \alpha M^1)}{EI} \right] \cdot \delta M \, ds + \int_0^L \left[\frac{(T^0 + \alpha T^1)}{GJ} \right] \cdot \delta T \, ds + \frac{(\alpha P^1)L}{EA} \cdot \delta P \quad (4.12)$$

Hence:

$$\begin{aligned} 0 = & \int_0^L \frac{M^0}{EI} \cdot \delta M \, ds + \alpha \cdot \int_0^L \frac{M^1}{EI} \cdot \delta M \, ds \\ & + \int_0^L \frac{T^0}{GJ} \cdot \delta T \, ds + \alpha \cdot \int_0^L \frac{T^1}{GJ} \cdot \delta T \, ds \\ & + \alpha \cdot \frac{P^1 L}{EA} \cdot \delta P \end{aligned} \quad (4.13)$$

And so finally:

$$\alpha = - \frac{\left[\int_0^L \frac{M^0}{EI} \cdot \delta M \, ds + \int_0^L \frac{T^0}{GJ} \cdot \delta T \, ds \right]}{\left[\int_0^L \frac{M^1}{EI} \cdot \delta M \, ds + \int_0^L \frac{T^1}{GJ} \cdot \delta T \, ds + \frac{P^1 L}{EA} \cdot \delta P \right]} \quad (4.14)$$

Equation (4.14) matches equation (3.15) except for the term relating to the cable. Thus the other four terms are evaluated exactly as per Example 3. The cable term,

$\frac{P^1 L}{EA} \cdot \delta P$, is easily found once it is recognized that $P^1 = \delta P = 1$ as was the case for the moment and torsion in Example 3. With all the terms thus evaluated, equation (4.14) becomes the same as equation (4.6) and the solution progresses as before.

The virtual work approach yields the same solution, but without the added insight of the source of each of the terms in equation (4.14) represented by equation (4.1).

7.5 Example 5

Problem

For the structure shown, the quarter-circle beam has the properties:

- torsional rigidity of GJ ;
- flexural rigidity about the local y - y axis EI_y ;
- flexural rigidity about the local z - z axis EI_z .

The cable has axial rigidity EA . Show that the tension in the cable due to the uniformly distributed load, w , shown is:

$$T = wR \left[\frac{4\beta + (\pi - 2)^2}{\beta\sqrt{2}} \right] \left[\pi \left(1 + \frac{1}{\lambda} \right) + \frac{1}{\beta} (3\pi - 8) + \frac{8\sqrt{2}}{\gamma R^2} \right]^{-1}$$

where $\beta = \frac{GJ}{EI_y}$, $\gamma = \frac{EA}{EI_y}$ and $\lambda = \frac{EI_z}{EI_y}$.

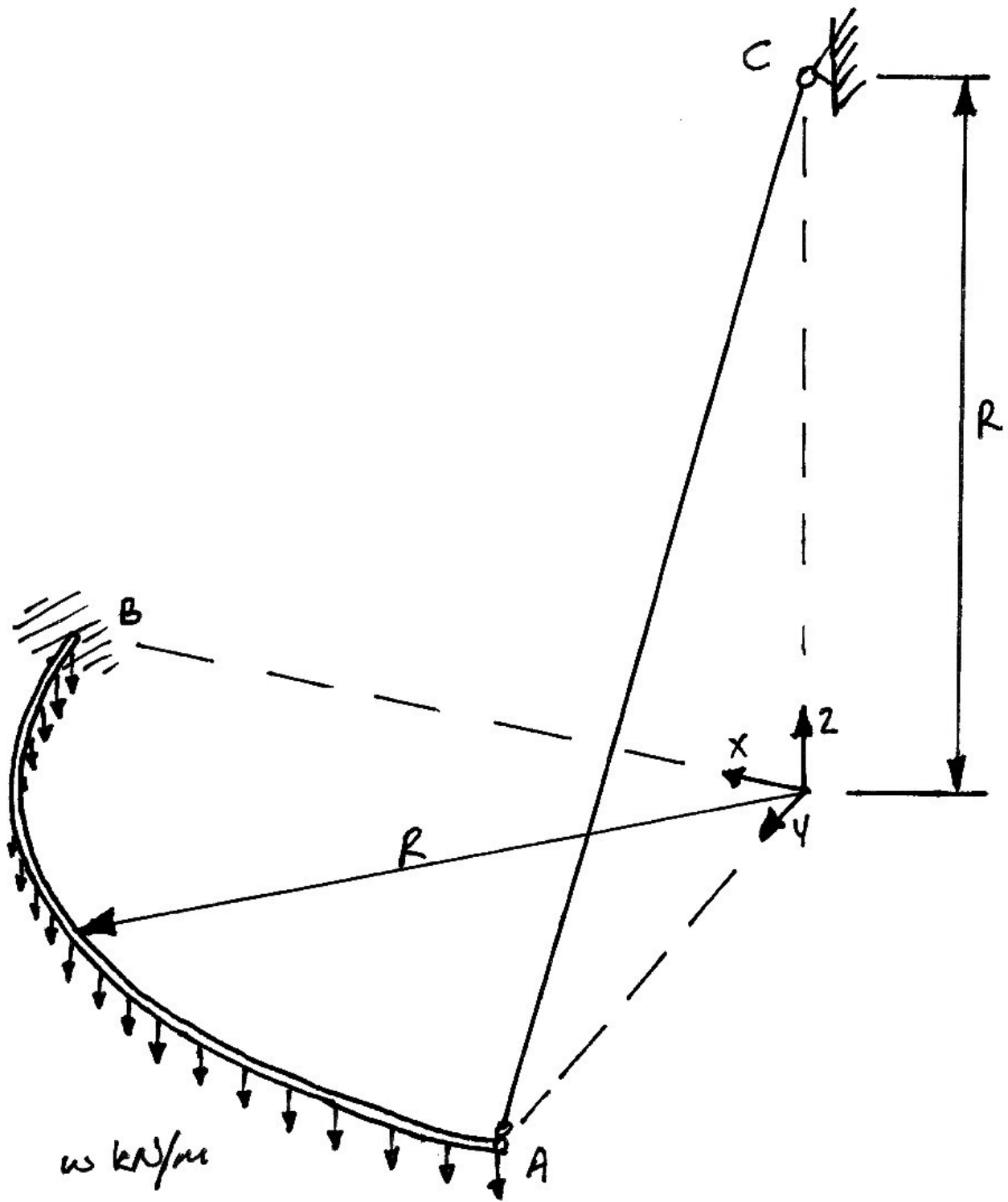

Solution

We will carry out this solution using both the empirical and virtual work approaches as was done for Example 4. However, it is in this example that the empirical approach will lead to savings in effort over the virtual work approach, as will be seen.

Empirical Form

Repeating our empirical equation:

$$\alpha = \frac{\delta \text{ due to actual loads}}{\delta \text{ due to unit redundant}} \left. \vphantom{\frac{\delta \text{ due to actual loads}}{\delta \text{ due to unit redundant}}} \right\} \begin{array}{l} \text{of primary structure along} \\ \text{line of action of redundant} \end{array} \quad (5.1)$$

We first examine the numerator with the following y-z axis elevation of the primary structure loaded with the actual loads:

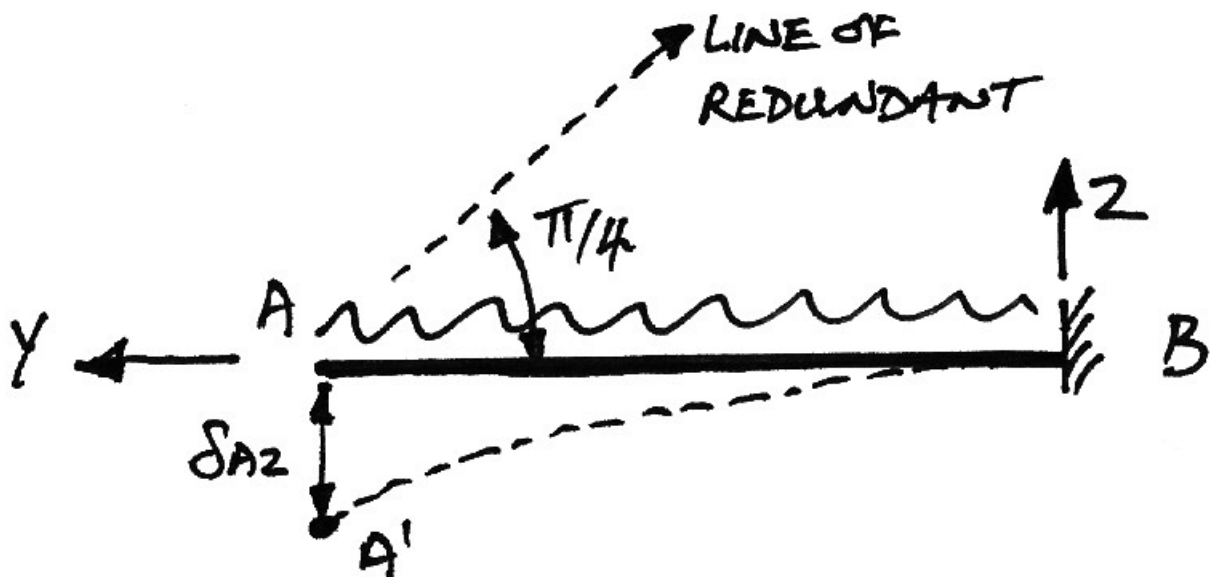

Noting that it is the deflection along the line of the redundant that is of interest, we can draw the following:

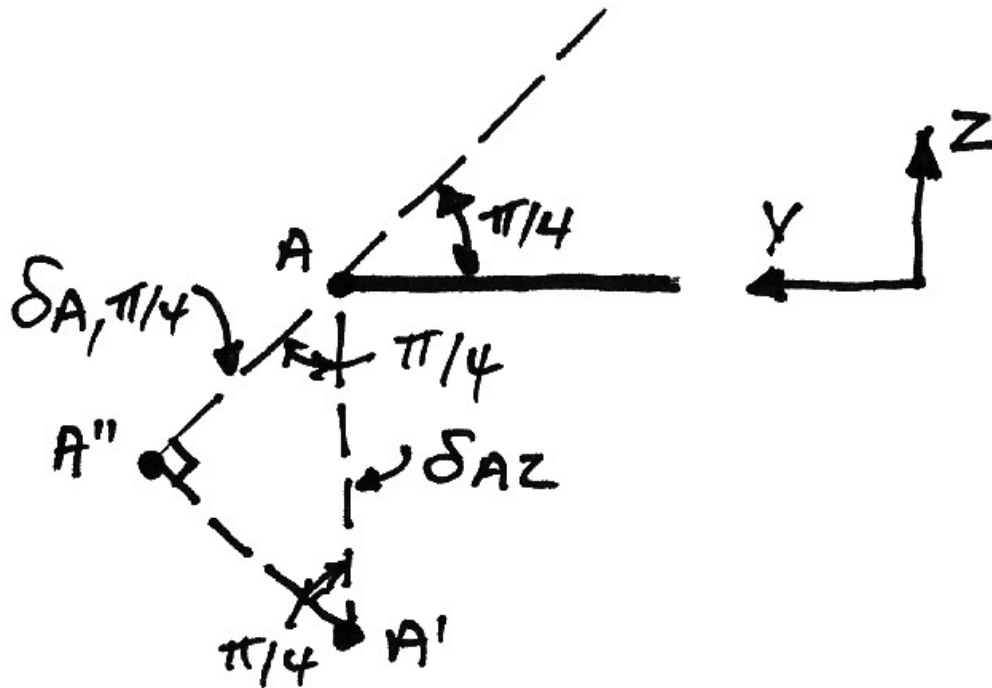

The deflection δ_{Az} , which is the distance $|AA''|$ is known from Example 2 to be:

$$\delta_{Az} = \frac{wR^4}{EI} \cdot \frac{1}{2} + \frac{wR^4}{GJ} \cdot \frac{(\pi - 2)^2}{8} \quad (5.2)$$

It is the deflection $|AA''|$ that is of interest here. Since the triangle $A-A'-A''$ is a 1-1- $\sqrt{2}$ triangle, we have:

$$\delta_{A, \pi/4} = \frac{\delta_{Az}}{\sqrt{2}} \quad (5.3)$$

And so the numerator is thus:

$$\delta_A^0 = \frac{wR^4}{2\sqrt{2}EI} + \frac{wR^4}{GJ} \cdot \frac{(\pi - 2)^2}{8\sqrt{2}} \quad (5.4)$$

To determine the denominator of equation (5.1) we must apply a unit load in lieu of the redundant (the cable) and determine the deflection in the direction of the cable.

Firstly we will consider the beam. We can determine the deflection in the z - and y -axes separately and combine, by examining the deflections that the components of the unit load cause:

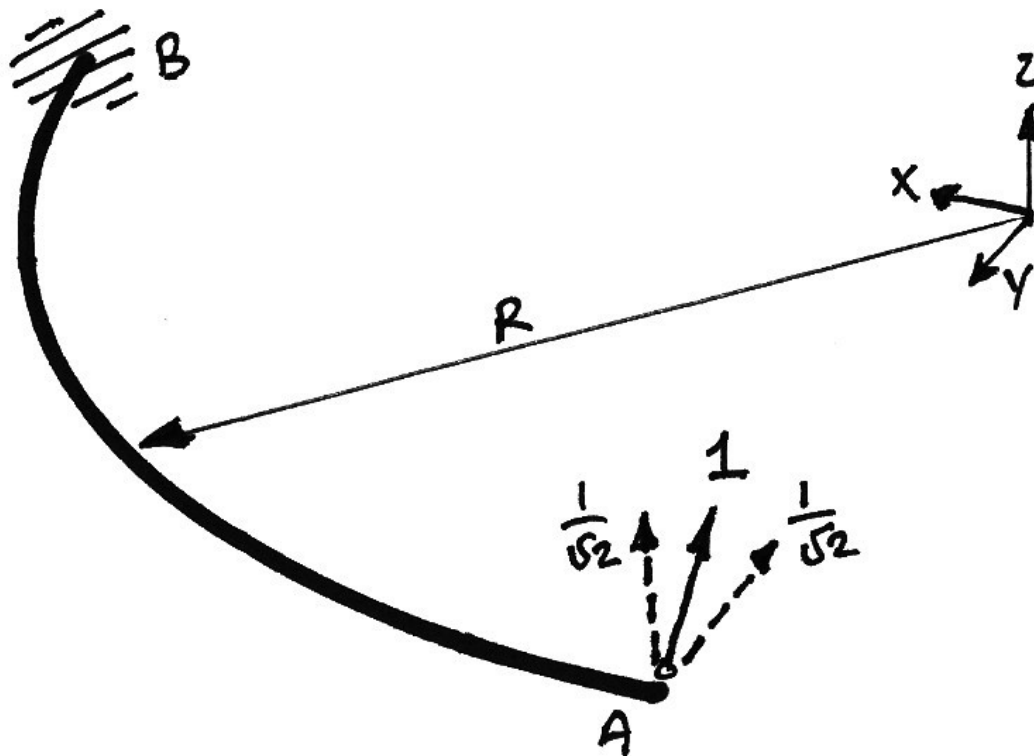

To find the deflection that a force of $\frac{1}{\sqrt{2}}$ causes in the z - and y -axes directions, we will instead find the deflections that unit loads cause in these directions, and then divide by $\sqrt{2}$.

Since we are now calculating deflections in two orthogonal planes of bending, we must consider the different flexural rigidities the beam will have in these two

directions: EI_y for the horizontal plane of bending (vertical loads), and EI_z for loads in the x - y plane, as shown in the figure:

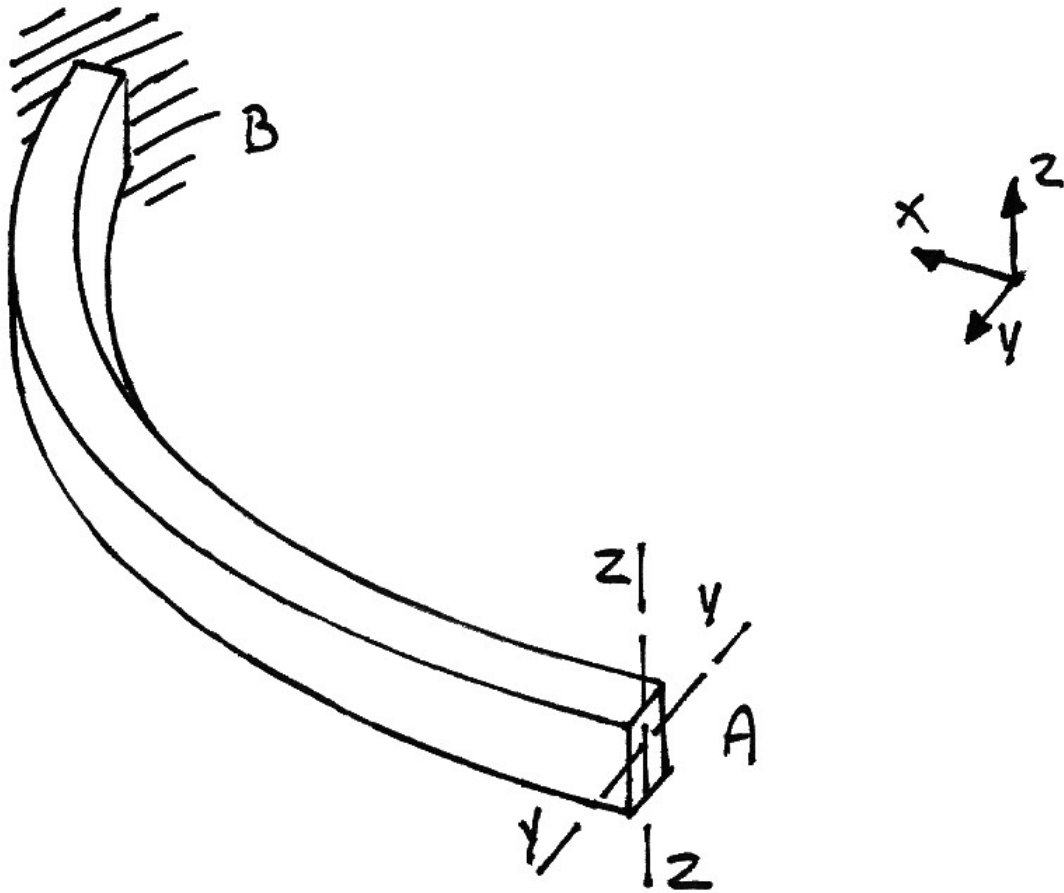

First, consider the deflection at A in the z -direction, caused by a unit load in the z -direction, as shown in the following diagram. This is the same as the deflection calculated in Example 1 and used in later examples:

$$\delta_{Az}^1 = \frac{1 \cdot R^3}{EI_y} \cdot \frac{\pi}{4} + \frac{1 \cdot R^3}{GJ} \left(\frac{3\pi - 8}{4} \right) \quad (5.5)$$

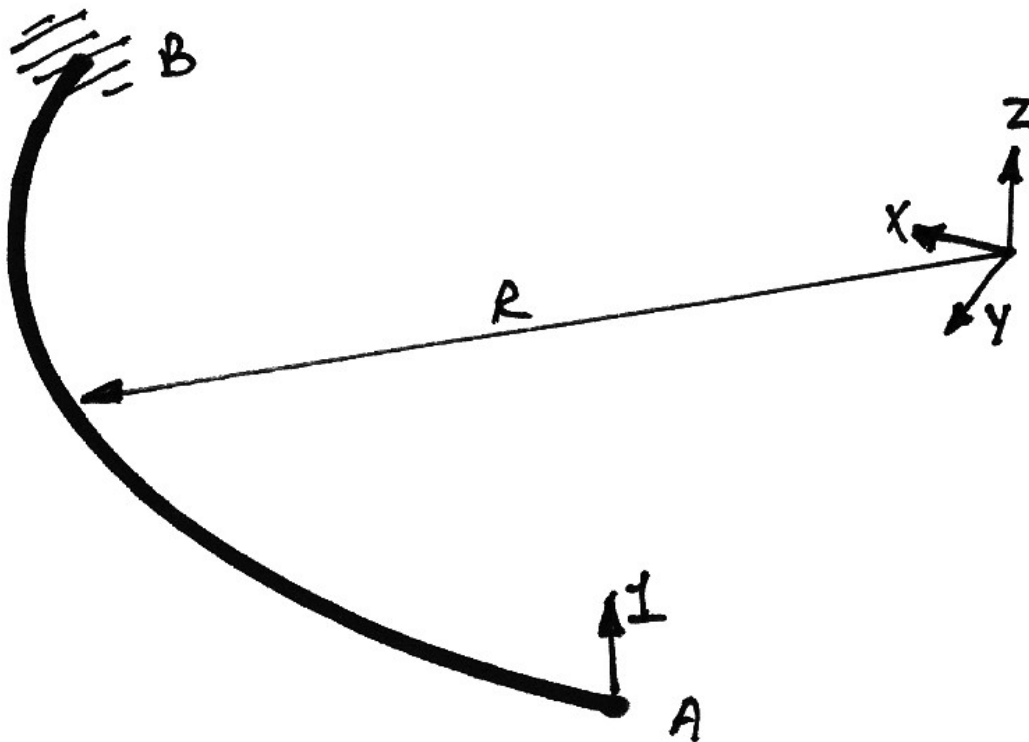

Considering the deflection at A in the y -direction next, we see from the following diagram that we do not have this result to hand, and so must calculate it:

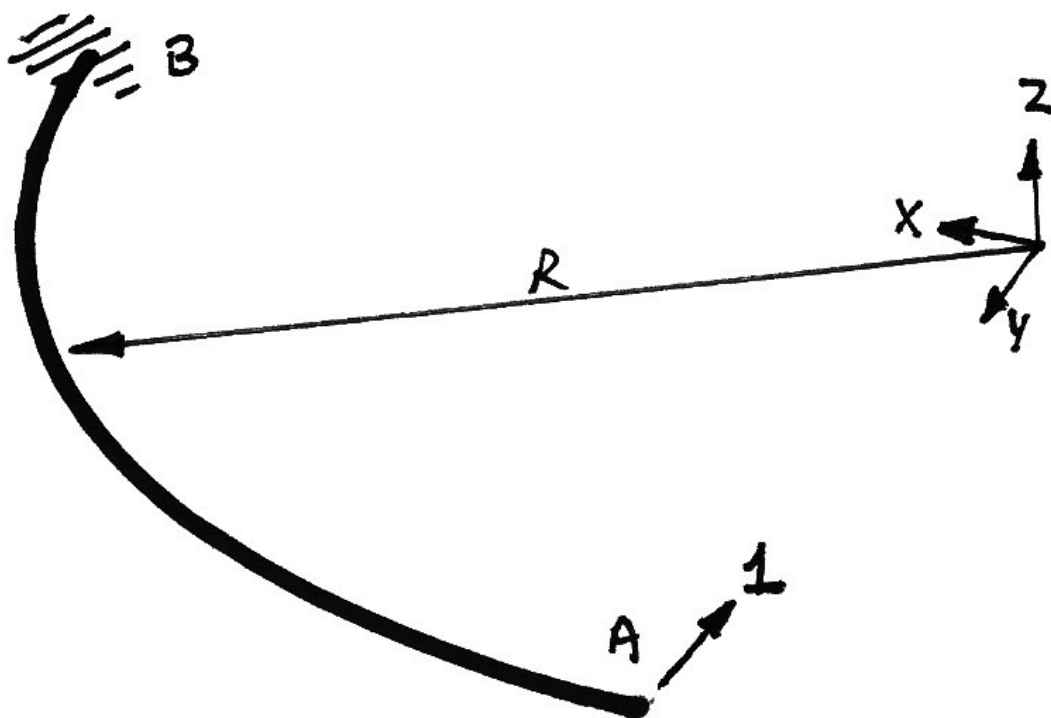

Looking at the elevation of the x - y plane, we have:

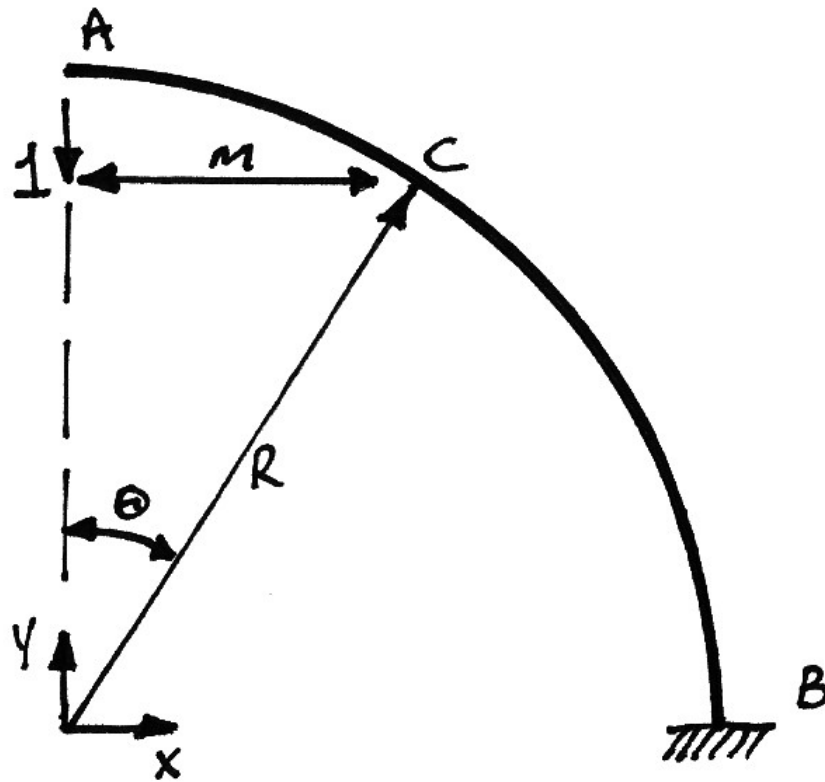

The lever arm, m , is:

$$m = R \sin \theta \quad (5.6)$$

Thus the moment at point C is:

$$M(\theta) = 1 \cdot m = 1 \cdot R \sin \theta \quad (5.7)$$

Using virtual work:

$$\begin{aligned}\delta W &= 0 \\ \delta W_E &= \delta W_I \\ 1 \cdot \delta_{Ay} &= \int \kappa \cdot \delta M \, ds\end{aligned}\tag{5.8}$$

In which we note that there is no torsion term, as the unit load in the x - y plane does not cause torsion in the structure. Using $\kappa = M/EI_z$ and $ds = R d\theta$:

$$1 \cdot \delta_{Ay} = \int_0^{\pi/2} \frac{M}{EI_z} \delta M R d\theta\tag{5.9}$$

Since $M = \delta M = R \sin \theta$, and assuming the beam is prismatic, we have:

$$1 \cdot \delta_{Ay} = \frac{R^3}{EI_z} \int_0^{\pi/2} \sin^2 \theta \, d\theta\tag{5.10}$$

This is the same as the first term in equation (1.7) and so immediately we obtain the solution as that of the first term of equation (1.11):

$$\delta_{Ay}^1 = \frac{R^3}{EI_z} \cdot \frac{\pi}{4}\tag{5.11}$$

In other words, the bending deflection at A in the x - y plane is the same as that in the z - y plane. This is apparent given that the lever arm is the same in both cases. However, the overall deflections are not the same due to the presence of torsion in the z - y plane.

Now that we have the deflections in the two orthogonal planes due to the units loads, we can determine the deflections in these planes due to the load $\frac{1}{\sqrt{2}}$:

$$\delta_{Az}^{1/\sqrt{2}} = \frac{R^3}{\sqrt{2}} \left[\frac{1}{EI_y} \cdot \frac{\pi}{4} + \frac{1}{GJ} \left(\frac{3\pi - 8}{4} \right) \right] \quad (5.12)$$

$$\delta_{Ay}^{1/\sqrt{2}} = \frac{R^3}{\sqrt{2}} \left[\frac{1}{EI_z} \cdot \frac{\pi}{4} \right] \quad (5.13)$$

The deflection along the line of action of the redundant is what is of interest:

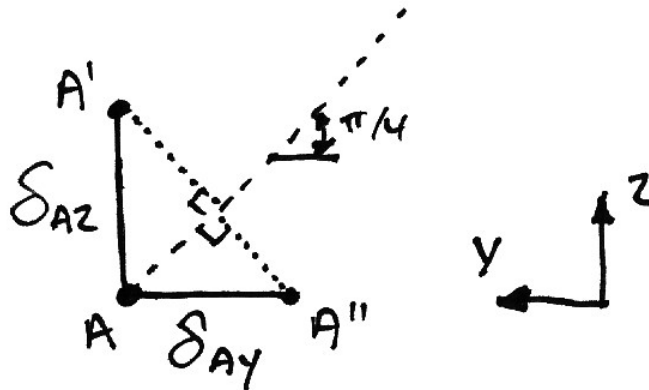

Looking at the contributions of each of these deflections along the line of action of the redundant:

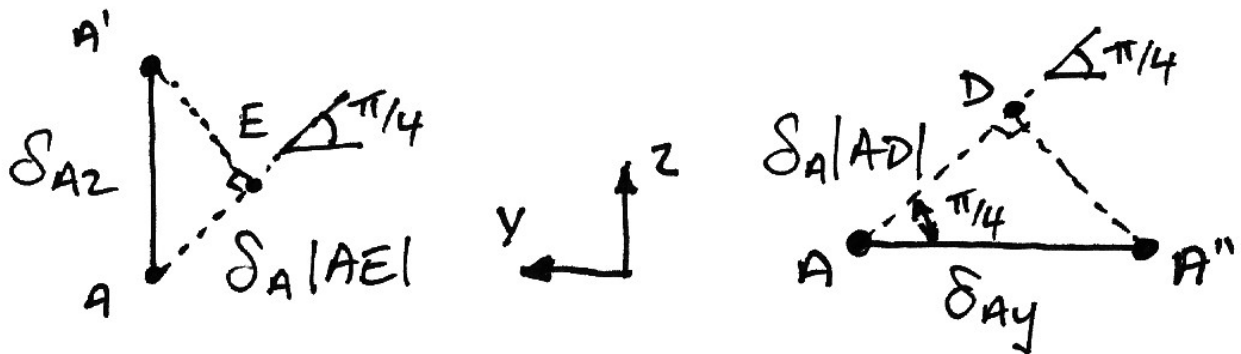

From this we have:

$$\begin{aligned}
 \delta_{Az} |AE| &= \frac{1}{\sqrt{2}} \cdot \delta_{Az}^{1/\sqrt{2}} \\
 &= \frac{1}{\sqrt{2}} \cdot \frac{R^3}{\sqrt{2}} \left[\frac{1}{EI_y} \cdot \frac{\pi}{4} + \frac{1}{GJ} \left(\frac{3\pi - 8}{4} \right) \right] \\
 &= \frac{R^3}{2} \left[\frac{1}{EI_y} \cdot \frac{\pi}{4} + \frac{1}{GJ} \left(\frac{3\pi - 8}{4} \right) \right]
 \end{aligned} \tag{5.14}$$

$$\begin{aligned}
 \delta_{Ay} |AD| &= \frac{1}{\sqrt{2}} \delta_{Ay}^{1/\sqrt{2}} \\
 &= \frac{1}{\sqrt{2}} \cdot \frac{R^3}{\sqrt{2}} \left[\frac{1}{EI_z} \cdot \frac{\pi}{4} \right] \\
 &= \frac{R^3}{2} \left[\frac{1}{EI_z} \cdot \frac{\pi}{4} \right]
 \end{aligned} \tag{5.15}$$

Thus the total deflection along the line of action of the redundant is:

$$\begin{aligned}
 \delta_{A,\pi/4}^1 &= \delta_{Az} |AE| + \delta_{Ay} |AD| \\
 &= \frac{R^3}{2} \left[\frac{1}{EI_y} \cdot \frac{\pi}{4} + \frac{1}{GJ} \left(\frac{3\pi - 8}{4} \right) \right] + \frac{R^3}{2} \left[\frac{1}{EI_z} \cdot \frac{\pi}{4} \right]
 \end{aligned} \tag{5.16}$$

This gives, finally:

$$\delta_{A,\pi/4}^1 = \frac{R^3}{2} \left[\frac{\pi}{4} \left(\frac{1}{EI_y} + \frac{1}{EI_z} \right) + \frac{1}{GJ} \left(\frac{3\pi - 8}{4} \right) \right] \tag{5.17}$$

To complete the denominator of equation (5.1), we must include the deflection that the cable undergoes due to the unit tension that is the redundant:

$$\begin{aligned}
 e &= \frac{1 \cdot L}{EA} \\
 &= \frac{R\sqrt{2}}{EA}
 \end{aligned}
 \tag{5.18}$$

The relationship between R and L is due to the geometry of the problem – the cable is at an angle of 45° .

Thus the denominator of equation (5.1) is finally:

$$\delta_{A,\pi/4}^1 = \frac{R^3}{2} \left[\frac{\pi}{4} \left(\frac{1}{EI_y} + \frac{1}{EI_z} \right) + \frac{1}{GJ} \left(\frac{3\pi - 8}{4} \right) + \frac{2\sqrt{2}}{R^2 EA} \right]
 \tag{5.19}$$

The solution for the tension in the cable becomes, from equations (5.1), (5.4) and (5.19):

$$T = \frac{wR^4 \left[\frac{1}{2\sqrt{2}EI} + \frac{1}{GJ} \cdot \frac{(\pi - 2)^2}{8\sqrt{2}} \right]}{\frac{R^3}{2} \left[\frac{\pi}{4} \left(\frac{1}{EI_y} + \frac{1}{EI_z} \right) + \frac{1}{GJ} \left(\frac{3\pi - 8}{4} \right) + \frac{2\sqrt{2}}{R^2 EA} \right]}
 \tag{5.20}$$

Using $\beta = \frac{GJ}{EI_y}$, $\gamma = \frac{EA}{EI_y}$ and $\lambda = \frac{EI_z}{EI_y}$, we have:

$$\begin{aligned}
 T &= wR \left[\frac{1}{2\sqrt{2}EI_y} + \frac{1}{\beta EI_y} \cdot \frac{(\pi - 2)^2}{8\sqrt{2}} \right] \\
 &\quad \times \left[\frac{\pi}{8} \left(\frac{1}{EI_y} + \frac{1}{\lambda EI_y} \right) + \frac{1}{\beta EI_y} \left(\frac{3\pi - 8}{8} \right) + \frac{\sqrt{2}}{R^2 \gamma EI_y} \right]^{-1}
 \end{aligned}
 \tag{5.21}$$

Continuing the algebra:

$$\begin{aligned}
 T &= wR \left[\frac{1}{2\sqrt{2}} + \frac{1}{\beta} \cdot \frac{(\pi-2)^2}{8\sqrt{2}} \right] \left[\frac{\pi}{8} \left(1 + \frac{1}{\lambda} \right) + \frac{1}{\beta} \left(\frac{3\pi-8}{8} \right) + \frac{\sqrt{2}}{\gamma R^2} \right]^{-1} \\
 &= wR \left[\frac{4\beta + (\pi-2)^2}{8\beta\sqrt{2}} \right] \left[\frac{\pi}{8} \left(1 + \frac{1}{\lambda} \right) + \frac{1}{8\beta} (3\pi-8) + \frac{8\sqrt{2}}{8\gamma R^2} \right]^{-1}
 \end{aligned} \tag{5.22}$$

Which finally gives the desired result:

$$T = wR \left[\frac{4\beta + (\pi-2)^2}{\beta\sqrt{2}} \right] \left[\pi \left(1 + \frac{1}{\lambda} \right) + \frac{1}{\beta} (3\pi-8) + \frac{8\sqrt{2}}{\gamma R^2} \right]^{-1} \tag{5.23}$$

Formal Virtual Work Approach

In the empirical approach carried out above there were some steps that are not obvious. Within a formal application of virtual work we will see how the results of the empirical approach are obtained ‘naturally’.

Following the methodology of the formal virtual work approach of Example 4, we can immediately jump to equation (4.10):

$$\delta_{Ay} \cdot 0 = \int_0^L \left[\frac{M}{EI} \right] \cdot \delta M \, ds + \int_0^L \left[\frac{T}{GJ} \right] \cdot \delta T \, ds + \frac{PL}{EA} \cdot \delta P \tag{5.24}$$

For the next step we need to recognize that the unit redundant causes bending about both axes of bending and so the first term in equation (5.24) must become:

$$\int_0^L \left[\frac{M}{EI} \right] \cdot \delta M \, ds = \int_0^L \left[\frac{M_Y}{EI_Y} \right] \cdot \delta M_Y \, ds + \int_0^L \left[\frac{M_Z}{EI_Z} \right] \cdot \delta M_Z \, ds \tag{5.25}$$

In which the notation M_Y and M_Z indicate the final bending moments of the actual structure about the Y - Y and Z - Z axes of bending respectively. Again we use superposition for the moments, torques and axial forces:

$$\begin{aligned}
 M_Y &= M_Y^0 + \alpha M_Y^1 \\
 M_Z &= M_Z^0 + \alpha M_Z^1 \\
 T &= T^0 + \alpha T^1 \\
 P &= P^0 + \alpha P^1
 \end{aligned}
 \tag{5.26}$$

We do not require more torsion terms since there is only torsion in the z - y plane. With equations (5.25) and (5.26), equation (5.24) becomes:

$$\begin{aligned}
 0 = \int_0^L \left[\frac{(M_Y^0 + \alpha M_Y^1)}{EI_Y} \right] \cdot \delta M_Y ds + \int_0^L \left[\frac{(M_Z^0 + \alpha M_Z^1)}{EI_Z} \right] \cdot \delta M_Z ds \\
 + \int_0^L \left[\frac{(T^0 + \alpha T^1)}{GJ} \right] \cdot \delta T ds + \frac{(P^0 + \alpha P^1)L}{EA} \cdot \delta P
 \end{aligned}
 \tag{5.27}$$

Multiplying out gives:

$$\begin{aligned}
 0 = \int_0^L \frac{M_Y^0}{EI_Y} \cdot \delta M_Y ds + \alpha \cdot \int_0^L \frac{M_Y^1}{EI_Y} \cdot \delta M_Y ds \\
 + \int_0^L \frac{M_Z^0}{EI_Z} \cdot \delta M_Z ds + \alpha \cdot \int_0^L \frac{M_Z^1}{EI_Z} \cdot \delta M_Z ds \\
 + \int_0^L \frac{T^0}{GJ} \cdot \delta T ds + \alpha \cdot \int_0^L \frac{T^1}{GJ} \cdot \delta T ds \\
 + \frac{P^0 L}{EA} \cdot \delta P + \alpha \cdot \frac{P^1 L}{EA} \cdot \delta P
 \end{aligned}
 \tag{5.28}$$

At this point we recognize that some of the terms are zero:

- There is no axial force in the primary structure since the cable is ‘cut’, and so $P^0 = 0$;
- There is no bending in the x - y plane (about the z - z axis of the beam) in the primary structure as the loading is purely vertical, thus $M_z^0 = 0$.

Including these points, and solving for α gives:

$$\alpha = - \frac{\left[\int_0^L \frac{M_Y^0}{EI_Y} \cdot \delta M_Y ds + \int_0^L \frac{T^0}{GJ} \cdot \delta T ds \right]}{\left[\int_0^L \frac{M_Y^1}{EI_Y} \cdot \delta M_Y ds + \int_0^L \frac{M_Z^1}{EI_Z} \cdot \delta M_Z ds + \int_0^L \frac{T^1}{GJ} \cdot \delta T ds + \frac{P^1 L}{EA} \cdot \delta P \right]} \quad (5.29)$$

We will next examine this expression term-by-term.

$$\frac{\int_0^L \frac{M_Y^0}{EI_Y} \cdot \delta M_Y ds}{}$$

For this term, M_Y^0 are the moments caused by the UDL about the y - y axis of bending, as per equation (2.2):

$$M_Y^0(\theta) = wR^2(1 - \cos\theta) \quad (5.30)$$

δM_Y are the moments about the same axis caused by the unit redundant. Since this redundant acts at an angle of 45° to the plane of interest, these moments are caused by its vertical component of $\frac{1}{\sqrt{2}}$. From equation (1.4), we thus have:

$$\delta M_Y(\theta) = -\frac{1}{\sqrt{2}} R \sin\theta \quad (5.31)$$

Notice that we have taken it that downwards loading causes positive bending moments. Thus we have:

$$\begin{aligned} \int_0^L \frac{M_Y^0}{EI_Y} \cdot \delta M_Y ds &= \frac{1}{EI_Y} \int_0^L [wR^2(1 - \cos \theta)] \left[-\frac{1}{\sqrt{2}} R \sin \theta \right] ds \\ &= -\frac{wR^3}{\sqrt{2}EI_Y} \int_0^{\pi/2} (\sin \theta - \sin \theta \cos \theta) R d\theta \end{aligned} \quad (5.32)$$

In which we have used the relation $ds = R d\theta$. From the integral appendix we thus have:

$$\begin{aligned} \int_0^L \frac{M_Y^0}{EI_Y} \cdot \delta M_Y ds &= -\frac{wR^4}{\sqrt{2}EI_Y} \left\{ [-\cos \theta]_0^{\pi/2} - \left[-\frac{1}{4} \cos 2\theta \right]_0^{\pi/2} \right\} \\ &= -\frac{wR^3}{\sqrt{2}EI_Y} \left\{ -[(0) - (1)] + \frac{1}{4} [(-1) - (1)] \right\} \end{aligned} \quad (5.33)$$

And so finally:

$$\int_0^L \frac{M_Y^0}{EI_Y} \cdot \delta M_Y ds = -\frac{wR^4}{2\sqrt{2}EI_Y} \quad (5.34)$$

$$\underline{\int_0^L \frac{T^0}{GJ} \cdot \delta T ds}$$

The torsion caused by the UDL in the primary structure is the same as that from equation (2.3):

$$T^0(\theta) = wR^2(\theta - \sin \theta) \quad (5.35)$$

Similarly to the bending term, the torsion caused by the unit redundant is $\frac{1}{\sqrt{2}}$ that of the unit load of equation (2.6):

$$\delta T(\theta) = -\frac{1}{\sqrt{2}}R(1 - \cos\theta) \quad (5.36)$$

Again note that we take the downwards loads as causing positive torsion. Noting $ds = Rd\theta$ we thus have:

$$\begin{aligned} \int_0^L \frac{T^0}{GJ} \cdot \delta T ds &= \frac{1}{GJ} \int_0^{\pi/2} [wR^2(\theta - \sin\theta)] \left[-\frac{1}{\sqrt{2}}R(1 - \cos\theta) \right] Rd\theta \\ &= -\frac{wR^4}{\sqrt{2}GJ} \int_0^{\pi/2} (\theta - \sin\theta)(1 - \cos\theta) d\theta \end{aligned} \quad (5.37)$$

This integral is exactly that of the second term in equation (2.8). Hence we can take its result from equation (2.9) to give:

$$\int_0^L \frac{T^0}{GJ} \cdot \delta T ds = -\frac{wR^4}{\sqrt{2}GJ} \cdot \frac{(\pi^2 - 2)^2}{8} \quad (5.38)$$

$$\underline{\int_0^L \frac{M_Y^1}{EI_Y} \cdot \delta M_Y ds}$$

For this term we recognize that $M_Y^1 = \delta M_Y$ and are the moments caused by the $\frac{1}{\sqrt{2}}$ component of the unit redundant in the vertical direction and are thus given by equation (1.1):

$$\delta M_Y = M_Y^1(\theta) = \frac{1}{\sqrt{2}} R \sin \theta \quad (5.39)$$

Hence this term becomes:

$$\begin{aligned} \int_0^L \frac{M_Y^1}{EI_Y} \cdot \delta M_Y ds &= \frac{1}{EI_Y} \int_0^{\pi/2} \left[\frac{1}{\sqrt{2}} R \sin \theta \right] \left[\frac{1}{\sqrt{2}} R \sin \theta \right] R d\theta \\ &= \frac{R^3}{2EI_Y} \int_0^{\pi/2} \sin^2 \theta d\theta \end{aligned} \quad (5.40)$$

From the integral tables we thus have:

$$\begin{aligned} \int_0^L \frac{M_Y^1}{EI_Y} \cdot \delta M_Y ds &= \frac{R^3}{2EI_Y} \left[\frac{\theta}{2} - \frac{1}{4} \sin 2\theta \right]_0^{\pi/2} \\ &= \frac{R^3}{2EI_Y} \left[\left(\frac{\pi}{4} - \frac{1}{4} \cdot 0 \right) - (0 - 0) \right] \end{aligned} \quad (5.41)$$

And so we finally have:

$$\int_0^L \frac{M_Y^1}{EI_Y} \cdot \delta M_Y ds = \frac{R^3}{EI_Y} \cdot \frac{\pi}{8} \quad (5.42)$$

$$\int_0^L \frac{M_Z^1}{EI_Z} \cdot \delta M_Z ds$$

Again we recognize that $M_z^1 = \delta M_z$ and are the moments caused by the $\frac{1}{\sqrt{2}}$ component of the unit redundant in the x - y plane and are thus given by equation (5.7). Hence this term becomes:

$$\int_0^L \frac{M_y^1}{EI_y} \cdot \delta M_y ds = \frac{1}{EI_y} \int_0^{\pi/2} \left[\frac{1}{\sqrt{2}} R \sin \theta \right] \left[\frac{1}{\sqrt{2}} R \sin \theta \right] R d\theta \quad (5.43)$$

This is the same as equation (5.40) except for the different flexural rigidity, and so the solution is got from equation (5.42) to be:

$$\int_0^L \frac{M_z^1}{EI_z} \cdot \delta M_z ds = \frac{R^3}{EI_z} \cdot \frac{\pi}{8} \quad (5.44)$$

$$\underline{\int_0^L \frac{T^1}{GJ} \cdot \delta T ds}$$

Once again note that $T^1 = \delta T$ and are the torques caused by the $\frac{1}{\sqrt{2}}$ vertical component of the unit redundant. From equation (1.2), then we have:

$$\delta T = T^1 = \frac{1}{\sqrt{2}} R(1 - \cos \theta) \quad (5.45)$$

Thus:

$$\begin{aligned} \int_0^L \frac{T^1}{GJ} \cdot \delta T ds &= \frac{1}{GJ} \int_0^{\pi/2} \left[\frac{1}{\sqrt{2}} R(1 - \cos \theta) \right] \left[\frac{1}{\sqrt{2}} R(1 - \cos \theta) \right] R d\theta \\ &= \frac{R^3}{2GJ} \int_0^{\pi/2} (1 - \cos \theta)^2 d\theta \end{aligned} \quad (5.46)$$

This integral is that of equation (1.9) and so the solution is:

$$\int_0^L \frac{T^1}{GJ} \cdot \delta T \, ds = \frac{R^3}{GJ} \left(\frac{3\pi - 8}{8} \right) \quad (5.47)$$

$$\frac{P^1 L}{EA} \cdot \delta P$$

Lastly then, since $P^1 = \delta P = 1$ and $L = R\sqrt{2}$, this term is easily calculated to be:

$$\frac{P^1 L}{EA} \cdot \delta P = \frac{R\sqrt{2}}{EA} \quad (5.48)$$

With the values for all terms now worked out, we substitute these values into equation (5.29) to determine the cable tension:

$$\alpha = - \frac{\left[-\frac{wR^4}{2\sqrt{2}EI_y} - \frac{wR^4}{\sqrt{2}GJ} \cdot \frac{(\pi^2 - 2)^2}{8} \right]}{\left[\frac{R^3}{EI_y} \cdot \frac{\pi}{8} + \frac{R^3}{EI_z} \cdot \frac{\pi}{8} + \frac{R^3}{GJ} \left(\frac{3\pi - 8}{8} \right) + \frac{R\sqrt{2}}{EA} \right]} \quad (5.49)$$

Cancelling the negatives and re-arranging gives:

$$T = \frac{wR^4 \left[\frac{1}{2\sqrt{2}EI_y} + \frac{1}{GJ} \cdot \frac{(\pi - 2)^2}{8\sqrt{2}} \right]}{\frac{R^3}{2} \left[\frac{\pi}{4} \left(\frac{1}{EI_y} + \frac{1}{EI_z} \right) + \frac{1}{GJ} \left(\frac{3\pi - 8}{4} \right) + \frac{2\sqrt{2}}{R^2 EA} \right]} \quad (5.50)$$

And this is the same as equation (5.20) and so the solution can proceed as before to obtain the tension in the cable as per equation (5.23).

Comparison of the virtual work with the empirical form illustrates the interpretation of each of the terms in the virtual work equation that is inherent in the empirical view of such problems.

7.6 Review of Examples 1 – 5

Example 1

For a radius of 2 m and a point load of 10 kN, the bending and torsion moment diagrams are:

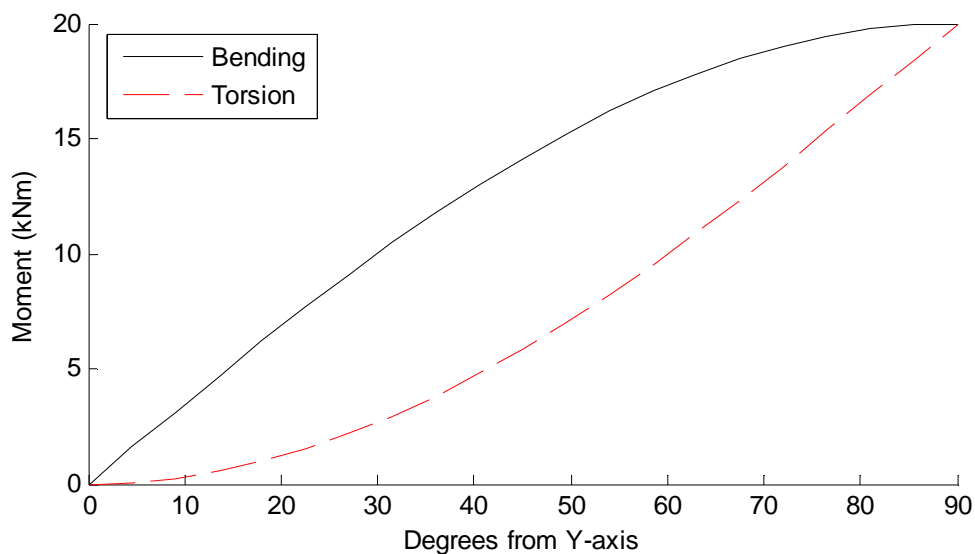

Using the equations derived in Example 1, the Matlab script for this is:

```
function RingBeam_Ex1
% Example 1
R = 2;      % m
P = 10;     % kN

theta = 0:(pi/2)/50:pi/2;
M = P*R*sin(theta);
T = P*R*(1-cos(theta));

hold on;
plot(theta.*180/pi,M,'k-');
plot(theta.*180/pi,T,'r--');
ylabel('Moment (kNm)');
xlabel('Degrees from Y-axis');
legend('Bending','Torsion','location','NW');
hold off;
```

Example 2

For a radius of 2 m and a UDL of 10 kN/m, the bending and torsion moment diagrams are:

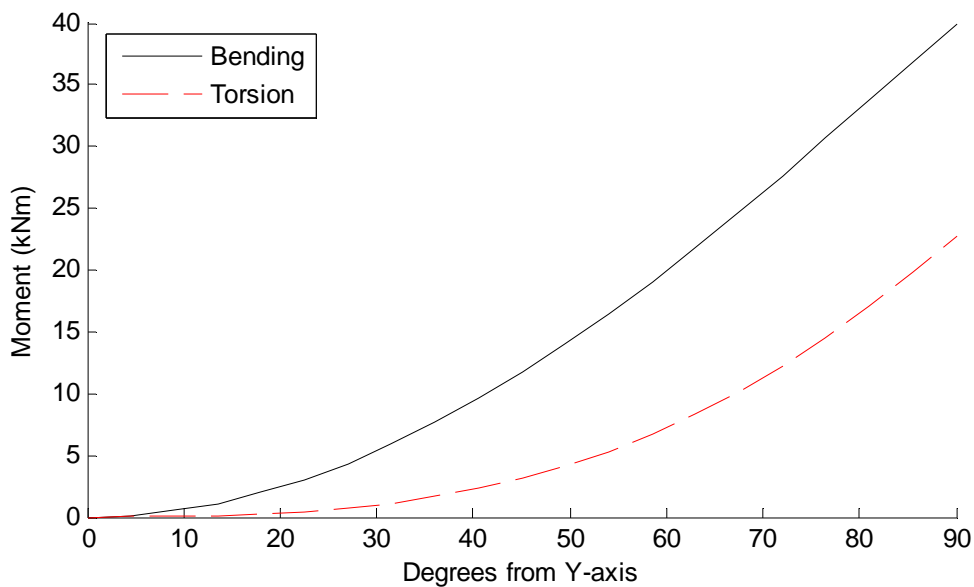

Using the equations derived in Example 2, the Matlab script for this is:

```
function RingBeam_Ex2
% Example 2
R = 2;      % m
w = 10;    % kN/m

theta = 0:(pi/2)/50:pi/2;
M = w*R^2*(1-cos(theta));
T = w*R^2*(theta-sin(theta));

hold on;
plot(theta.*180/pi,M,'k-');
plot(theta.*180/pi,T,'r--');
ylabel('Moment (kNm)');
xlabel('Degrees from Y-axis');
legend('Bending','Torsion','location','NW');
hold off;
```

Example 3

For the parameters given below, the bending and torsion moment diagrams are:

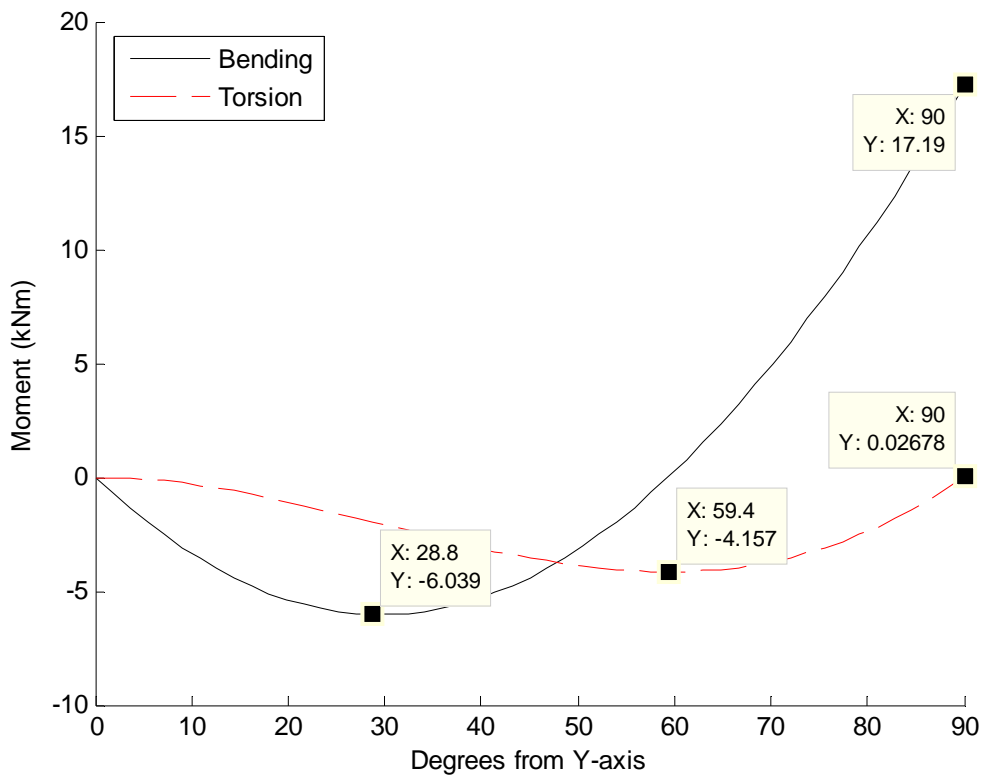

Using the equations derived in Example 3, the Matlab script for this is:

```
function [M T alpha] = RingBeam_Ex3(beta)
% Example 3
R = 2;           % m
w = 10;         % kN/m
I = 2.7e7;      % mm4
J = 5.4e7;      % mm4
E = 205;        % kN/mm2
v = 0.30;      % Poisson's Ratio
G = E/(2*(1+v)); % Shear modulus
EI = E*I/1e6;  % kNm2
GJ = G*J/1e6;  % kNm2
if nargin < 1
    beta = GJ/EI; % Torsion stiffness ratio
end
```

```
alpha = w*R*(4*beta+(pi-2)^2)/(2*beta*pi+2*(3*pi-8));

theta = 0:(pi/2)/50:pi/2;
M0 = w*R^2*(1-cos(theta));
T0 = w*R^2*(theta-sin(theta));
M1 = -R*sin(theta);
T1 = -R*(1-cos(theta));

M = M0 + alpha.*M1;
T = T0 + alpha.*T1;

if nargin < 1
    hold on;
    plot(theta.*180/pi,M,'k-');
    plot(theta.*180/pi,T,'r--');
    ylabel('Moment (kNm)');
    xlabel('Degrees from Y-axis');
    legend('Bending','Torsion','location','NW');
    hold off;
end
```

The vertical reaction at *A* is found to be 11.043 kN. Note that the torsion is (essentially) zero at support *B*. Other relevant values for bending moment and torsion are given in the graph.

By changing β , we can examine the effect of the relative stiffnesses on the vertical reaction at *A*, and consequently the bending moments and torsions. In the following plot, the reaction at *A* and the maximum and minimum bending and torsion moments are given for a range of β values.

Very small values of β reflect little torsional rigidity and so the structure movements will be dominated by bending solely. Conversely, large values of β reflect structures with small bending stiffness in comparison to torsional stiffness. At either extreme the variables converge to asymptotes of extreme behaviour. For $0.1 \leq \beta \leq 10$ the variables are sensitive to the relative stiffnesses. Of course, this reflects the normal range of values for β .

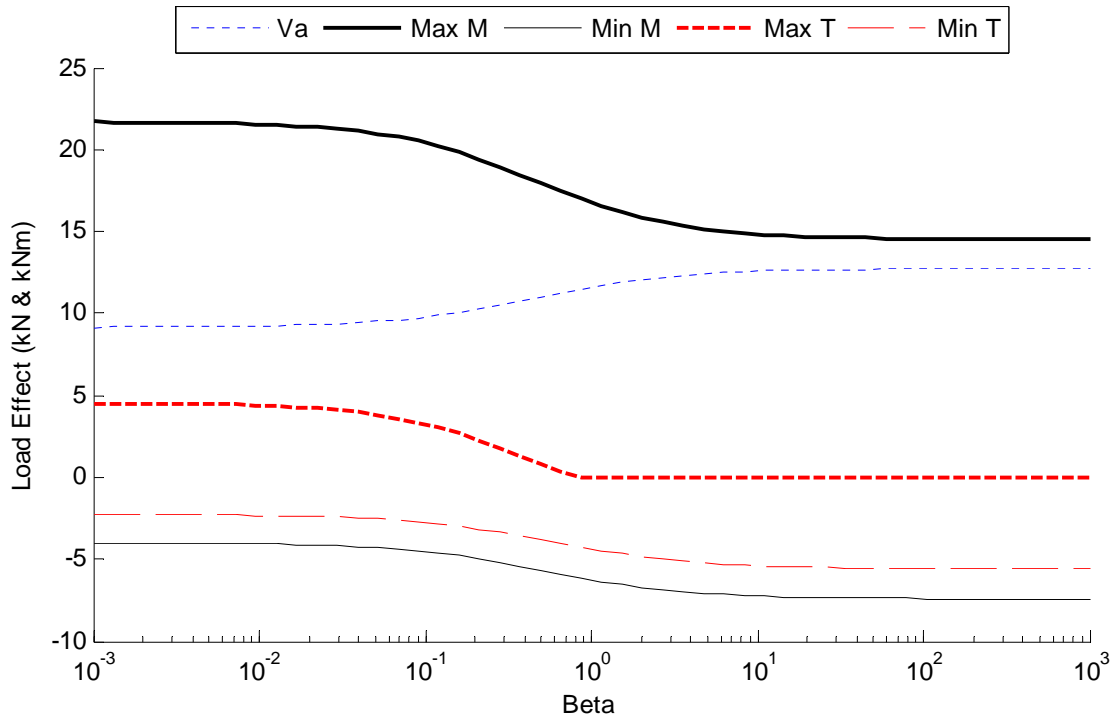

The Matlab code to produce this figure is:

```
% Variation with Beta
beta = logspace(-3,3);
n = length(beta);
for i = 1:n
    [M T alpha] = RingBeam_Ex3(beta(i));
    Eff(i,1) = alpha;
    Eff(i,2) = max(M);
    Eff(i,3) = min(M);
    Eff(i,4) = max(T);
    Eff(i,5) = min(T);
end

hold on;
plot(beta, Eff(:,1), 'b:');
plot(beta, Eff(:,2), 'k-', 'LineWidth', 2);
plot(beta, Eff(:,3), 'k-');
plot(beta, Eff(:,4), 'r--', 'LineWidth', 2);
plot(beta, Eff(:,5), 'r--');
hold off;
set(gca, 'xscale', 'log');
legend('Va', 'Max M', 'Min M', 'Max T', 'Min T', 'Location', 'NO', ...
    'Orientation', 'horizontal');
xlabel('Beta');
ylabel('Load Effect (kN & kNm)');
```

Example 4

For a 20 mm diameter cable, and for the other parameters given below, the bending and torsion moment diagrams are:

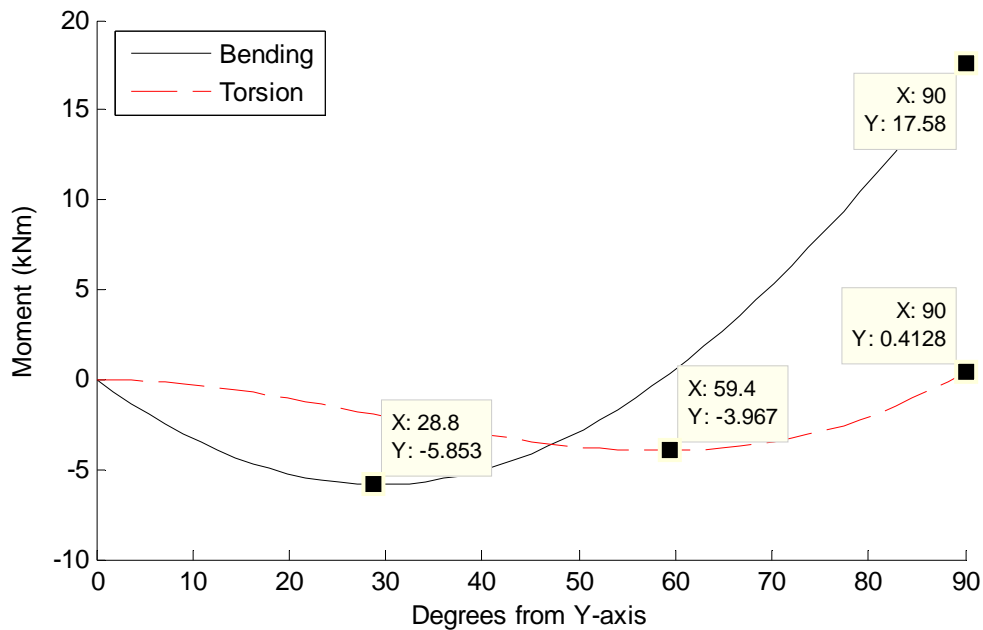

The values in the graph should be compared to those of Example 3, where the support was rigid. The Matlab script, using Example 4's equations, for this problem is:

```
function [M T alpha] = RingBeam_Ex4(gamma,beta)
% Example 4
R = 2;           % m - radius of beam
L = 2;           % m - length of cable
w = 10;          % kN/m - UDL
A = 314;         % mm2 - area of cable
I = 2.7e7;       % mm4
J = 5.4e7;       % mm4
E = 205;         % kN/mm2
v = 0.30;        % Poisson's Ratio
G = E/(2*(1+v)); % Shear modulus
EA = E*A;        % kN - axial stiffness
EI = E*I/1e6;    % kNm2
GJ = G*J/1e6;    % kNm2
if nargin < 2
    beta = GJ/EI; % Torsion stiffness ratio
```

```

end
if nargin < 1
    gamma = EA/EI;      % Axial stiffness ratio
end

alpha      =      w*R*(4*beta+(pi-2)^2)/(2*beta*pi+2*(3*pi-
8)+8*(beta/gamma)*(L/R^3));

theta = 0:(pi/2)/50:pi/2;
M0 = w*R^2*(1-cos(theta));
T0 = w*R^2*(theta-sin(theta));
M1 = -R*sin(theta);
T1 = -R*(1-cos(theta));

M = M0 + alpha.*M1;
T = T0 + alpha.*T1;

if nargin < 1
    hold on;
    plot(theta.*180/pi,M,'k-');
    plot(theta.*180/pi,T,'r--');
    ylabel('Moment (kNm)');
    xlabel('Degrees from Y-axis');
    legend('Bending','Torsion','location','NW');
    hold off;
end

```

Whilst keeping the β constant, we can examine the effect of varying the cable stiffness on the behaviour of the structure, by varying γ . Again we plot the reaction at A and the maximum and minimum bending and torsion moments for the range of γ values.

For small γ , the cable has little stiffness and so the primary behaviour will be that of Example 1, where the beam was a pure cantilever. Conversely for high γ , the cable is very stiff and so the beam behaves as in Example 3, where there was a pinned support at A. Compare the maximum (hogging) bending moments for these two cases with the graph. Lastly, for $0.01 \leq \gamma \leq 3$, the cable and beam interact and the variables are sensitive to the exact ratio of stiffness. Typical values in practice are towards the lower end of this region.

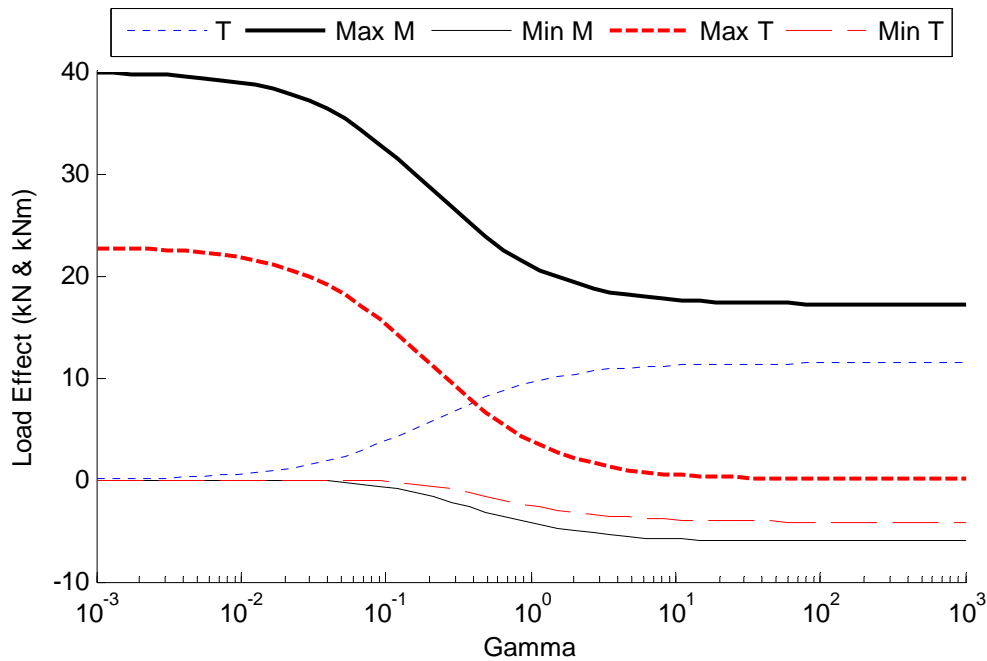

The Matlab code for this plot is:

```
% Variation with Gamma
gamma = logspace(-3,3);
n = length(gamma);
for i = 1:n
    [M T alpha] = RingBeam_Ex4(gamma(i));
    Eff(i,1) = alpha;
    Eff(i,2) = max(M);
    Eff(i,3) = min(M);
    Eff(i,4) = max(T);
    Eff(i,5) = min(T);
end

hold on;
plot(gamma, Eff(:,1), 'b:');
plot(gamma, Eff(:,2), 'k-', 'LineWidth', 2);
plot(gamma, Eff(:,3), 'k-');
plot(gamma, Eff(:,4), 'r--', 'LineWidth', 2);
plot(gamma, Eff(:,5), 'r--');
hold off;
set(gca, 'xscale', 'log');
legend('T', 'Max M', 'Min M', 'Max T', 'Min T', 'Location', 'NO', ...
    'Orientation', 'horizontal');
xlabel('Gamma');
ylabel('Load Effect (kN & kNm)');
```

Example 5

Again we consider a 20 mm diameter cable, and a doubly symmetric section, that is $EI_y = EI_z$. For the parameters below the bending and torsion moment diagrams are:

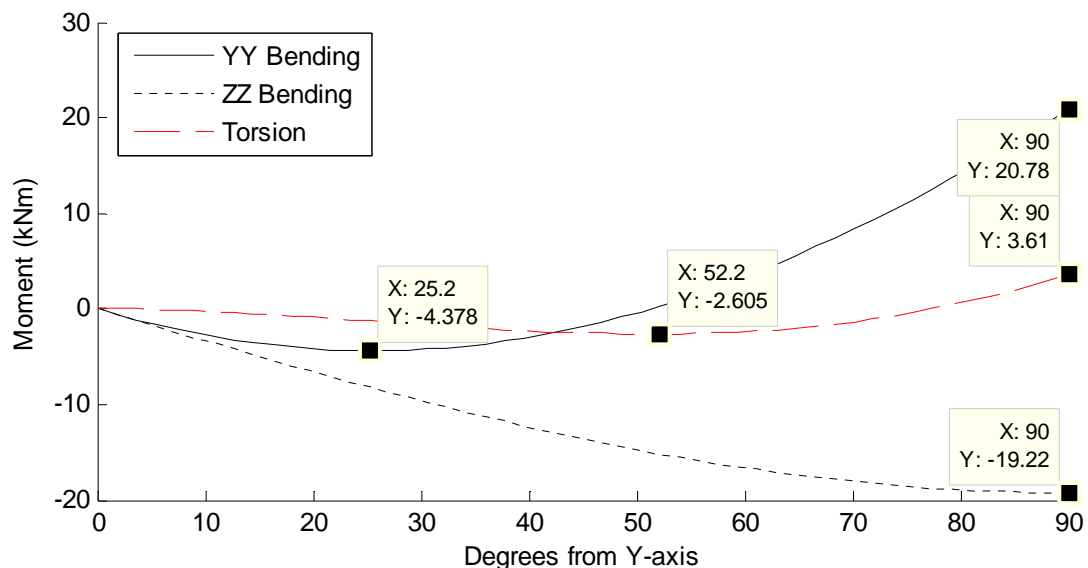

The values in the graph should be compared to those of Example 4, where the cable was vertical. The Matlab script, using Example 5's equations, for this problem is:

```
function [My T alpha] = RingBeam_Ex5(lamda, gamma, beta)
% Example 5
R = 2; % m - radius of beam
w = 10; % kN/m - UDL
A = 314; % mm2 - area of cable
Iy = 2.7e7; % mm4
Iz = 2.7e7; % mm4
J = 5.4e7; % mm4
E = 205; % kN/mm2
v = 0.30; % Poisson's Ratio
G = E/(2*(1+v)); % Shear modulus
EA = E*A; % kN - axial stiffness
EIy = E*Iy/1e6; % kNm2
EIz = E*Iz/1e6; % kNm2
GJ = G*J/1e6; % kNm2
if nargin < 3
    beta = GJ/EIy; % Torsion stiffness ratio
end
```



```

if nargin < 2
    gamma = EA/EIy;      % Axial stiffness ratio
end
if nargin < 1
    lamda = EIy/EIz;    % Bending stiffness ratio
end

numerator = (4*beta+(pi-2)^2)/(beta*sqrt(2));
denominator = (pi*(1+1/lamda)+(3*pi-8)/beta+8*sqrt(2))/(gamma*R^2);
alpha = w*R*numerator/denominator;

theta = 0:(pi/2)/50:pi/2;
M0y = w*R^2*(1-cos(theta));
M0z = 0;
T0 = w*R^2*(theta-sin(theta));
M1y = -R*sin(theta);
M1z = -R*sin(theta);
T1 = -R*(1-cos(theta));

My = M0y + alpha.*M1y;
Mz = M0z + alpha.*M1z;
T = T0 + alpha.*T1;

if nargin < 1
    hold on;
    plot(theta.*180/pi,My,'k');
    plot(theta.*180/pi,Mz,'k:');
    plot(theta.*180/pi,T,'r--');
    ylabel('Moment (kNm)');
    xlabel('Degrees from Y-axis');
    legend('YY Bending','ZZ Bending','Torsion','location','NW');
    hold off;
end

```

Keep all parameters constant, but varying the ratio of the bending rigidities by changing λ , the output variables are as shown below. For low λ (a tall slender beam) the beam behaves as a cantilever. Thus the cable requires some transverse bending stiffness to be mobilized. With high λ (a wide flat beam) the beam behaves as if supported at A with a vertical roller. Only vertical movement takes place, and the effect of the cable is solely its vertical stiffness at A. Usually $0.1 \leq \lambda \leq 2$ which means that the output variables are usually quite sensitive to the input parameters.

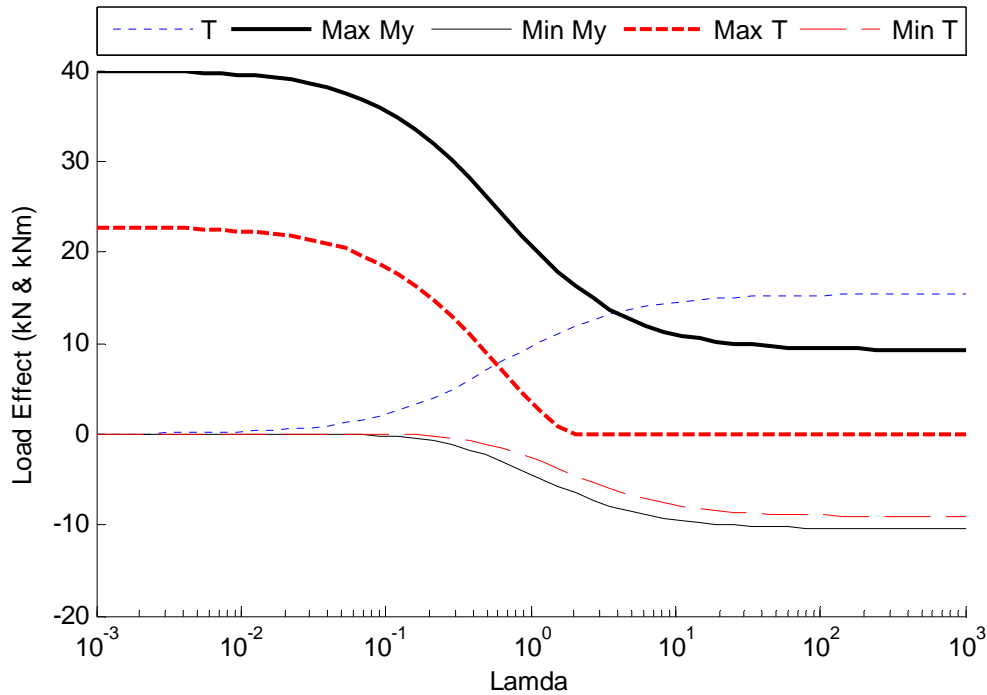

The Matlab code to produce this graph is:

```
% Variation with Lamda
lamda = logspace(-3,3);
n = length(lamda);
for i = 1:n
    [My T alpha] = RingBeam_Ex5(lamda(i));
    Eff(i,1) = alpha;
    Eff(i,2) = max(My);
    Eff(i,3) = min(My);
    Eff(i,4) = max(T);
    Eff(i,5) = min(T);
end

hold on;
plot(lamda, Eff(:,1), 'b:');
plot(lamda, Eff(:,2), 'k-', 'LineWidth', 2);
plot(lamda, Eff(:,3), 'k-');
plot(lamda, Eff(:,4), 'r--', 'LineWidth', 2);
plot(lamda, Eff(:,5), 'r--');
hold off;
set(gca, 'xscale', 'log');
legend('T', 'Max My', 'Min My', 'Max T', 'Min T', 'Location', 'NO', ...
    'Orientation', 'horizontal');
xlabel('Lamda');
ylabel('Load Effect (kN & kNm)');
```