

Structural Analysis III
The Moment Area Method –
Mohr's Theorems

2008/9

Dr. Colin Caprani,
Chartered Engineer

Contents

1. Introduction	3
1.1 Purpose	3
2. Theory.....	5
2.1 Basis.....	5
2.2 Mohr's First Theorem (Mohr I).....	7
2.3 Mohr's Second Theorem (Mohr II).....	10
2.4 Area Properties	13
3. Application to Determinate Structures	14
3.1 Basic Examples.....	14
3.2 Finding Deflections	17
3.3 Problems	24
4. Application to Indeterminate Structures.....	25
4.1 Basis of Approach	25
4.2 Example 6: Propped Cantilever.....	26
4.3 Example 7: 2-Span Beam	33
4.4 Example 8: Simple Frame	39
4.5 Example 9: Complex Frame.....	45
4.6 Problems	54

1. Introduction

1.1 Purpose

The moment-area method, developed by Otto Mohr in 1868, is a powerful tool for finding the deflections of structures primarily subjected to bending. Its ease of finding deflections of determinate structures makes it ideal for solving indeterminate structures, using compatibility of displacement.



Otto C. Mohr (1835-1918)

Mohr's Theorems also provide a relatively easy way to derive many of the classical methods of structural analysis. For example, we will use Mohr's Theorems later to derive the equations used in Moment Distribution. The derivation of Clayperon's Three Moment Theorem also follows readily from application of Mohr's Theorems.

Blank on purpose.

2. Theory

2.1 Basis

We consider a length of beam AB in its undeformed and deformed state, as shown on the next page. Studying this diagram *carefully*, we note:

1. AB is the original unloaded length of the beam and $A'B'$ is the deflected position of AB when loaded.
2. The angle subtended at the centre of the arc $A'OB'$ is θ and is the change in curvature from A' to B' .
3. PQ is a very short length of the beam, measured as ds along the curve and dx along the x -axis.
4. $d\theta$ is the angle subtended at the centre of the arc ds .
5. $d\theta$ is the change in curvature from P to Q .
6. M is the average bending moment over the portion dx between P and Q .
7. The distance Δ is known as the vertical intercept and is the distance from B' to the produced tangent to the curve at A' which crosses under B' at C . It is measured perpendicular to the undeformed neutral axis (i.e. the x -axis) and so is 'vertical'.

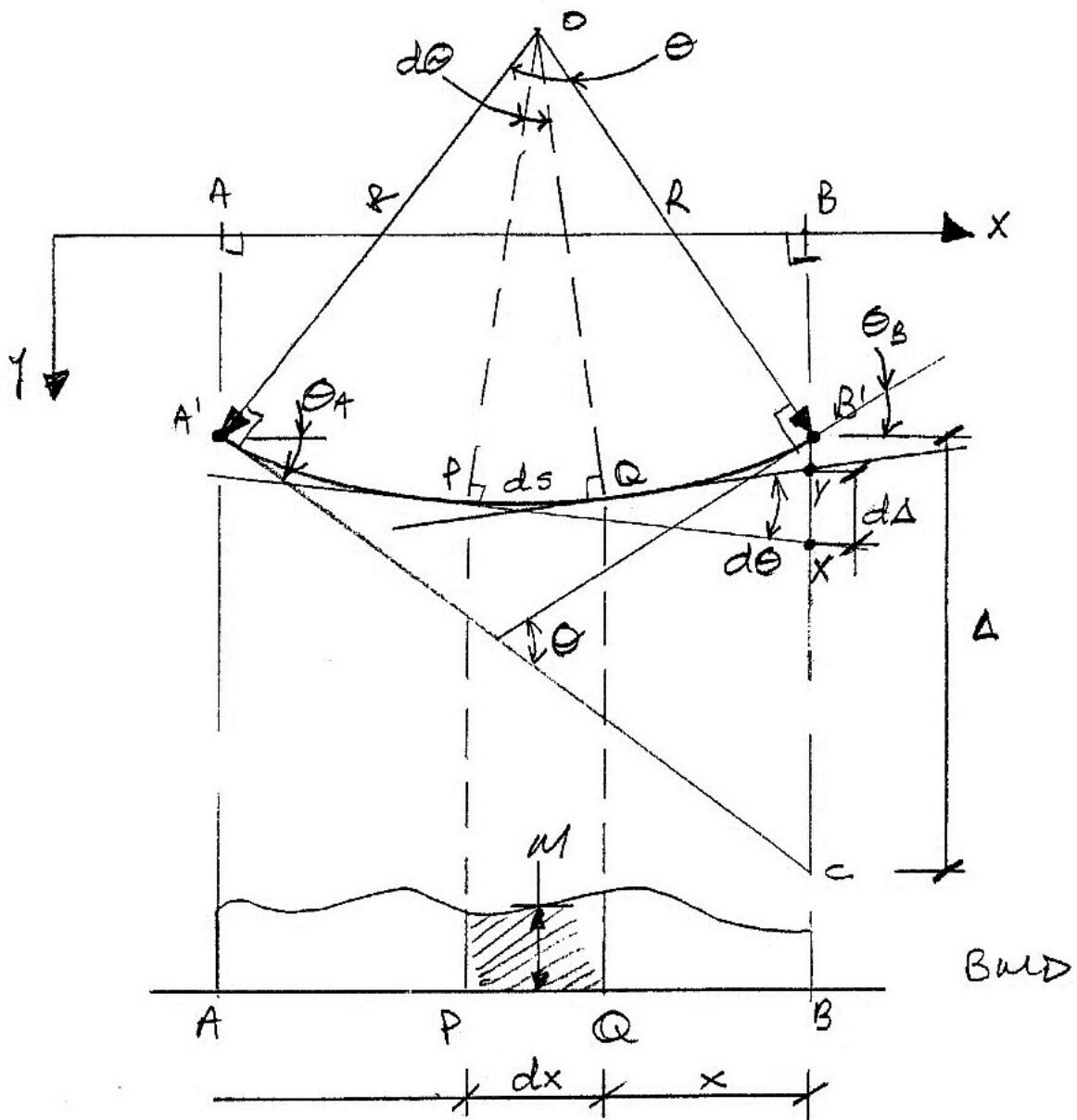
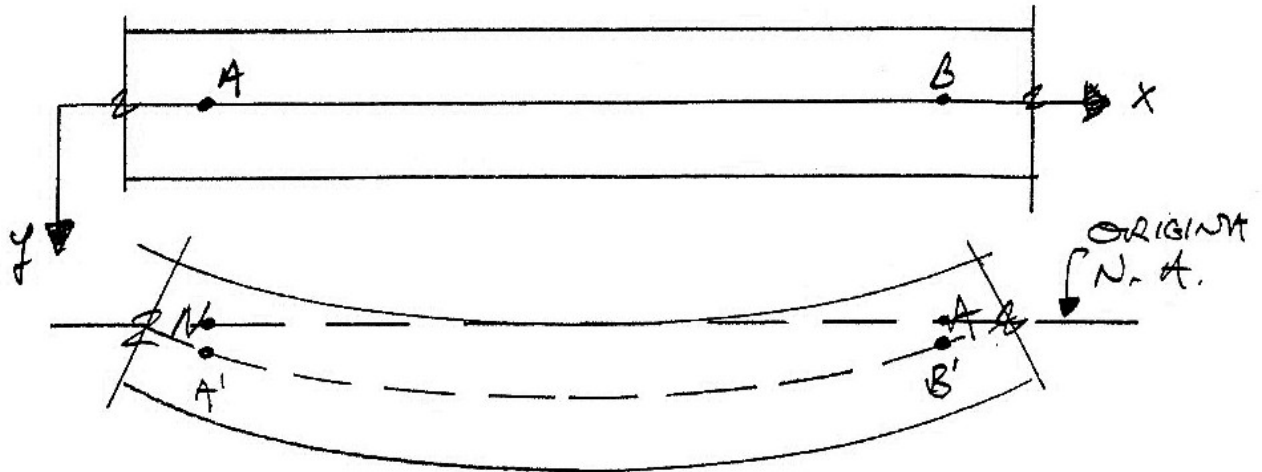

Basis of Theory

2.2 Mohr's First Theorem (Mohr I)

Development

Noting that the angles are always measured in radians, we have:

$$ds = R \cdot d\theta$$
$$\therefore R = \frac{ds}{d\theta}$$

From the Euler-Bernoulli Theory of Bending, we know:

$$\frac{1}{R} = \frac{M}{EI}$$

Hence:

$$d\theta = \frac{M}{EI} \cdot ds$$

But for small deflections, the chord and arc length are similar, i.e. $ds \approx dx$, giving:

$$d\theta = \frac{M}{EI} \cdot dx$$

The total change in rotation between A and B is thus:

$$\int_A^B d\theta = \int_A^B \frac{M}{EI} dx$$

The term M/EI is the curvature and the diagram of this term as it changes along a beam is the curvature diagram (or more simply the M/EI diagram). Thus we have:

$$d\theta_{BA} = \theta_B - \theta_A = \int_A^B \frac{M}{EI} dx$$

This is interpreted as:

$$\left[\text{Change in slope} \right]_{AB} = \left[\text{Area of } \frac{M}{EI} \text{ diagram} \right]_{AB}$$

This is Mohr's First Theorem (Mohr I):

The change in slope over any length of a member subjected to bending is equal to the area of the curvature diagram over that length.

Usually the beam is prismatic and so E and I do not change over the length AB , whereas the bending moment M will change. Thus:

$$\theta_{AB} = \frac{1}{EI} \int_A^B M dx$$
$$\left[\text{Change in slope} \right]_{AB} = \frac{\left[\text{Area of } M \text{ diagram} \right]_{AB}}{EI}$$

Example 1

For the cantilever beam shown, we can find the rotation at B easily:

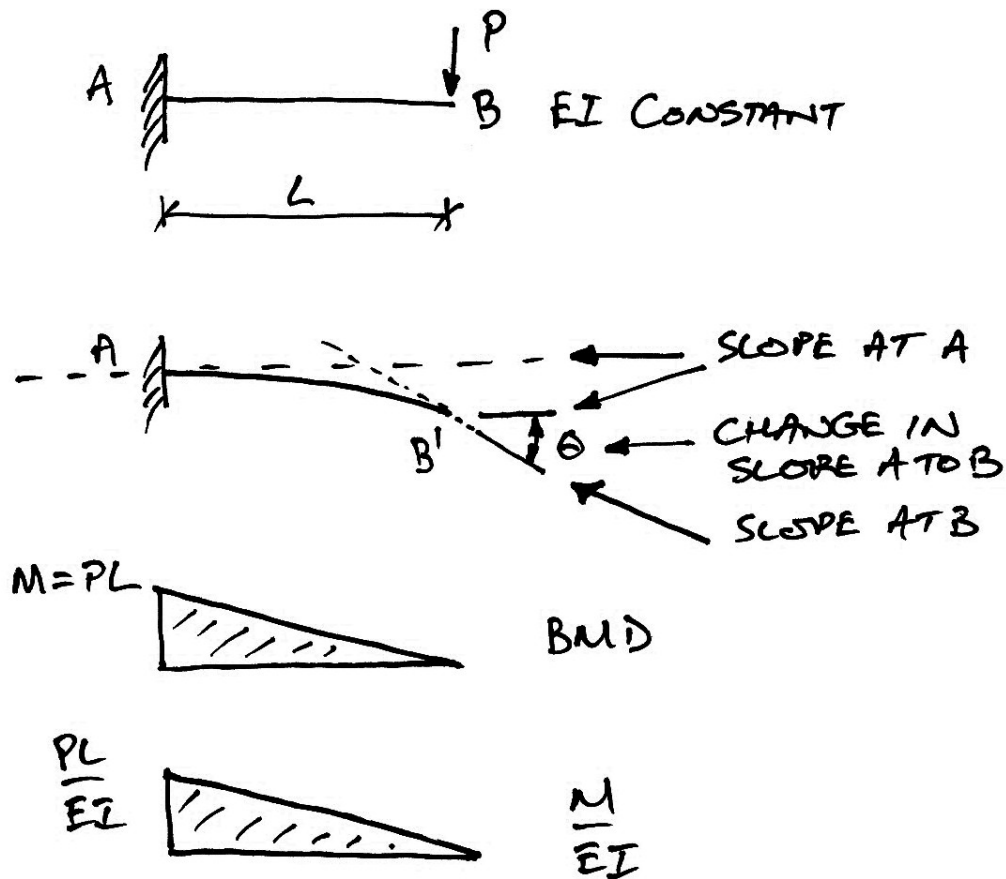

Thus, from Mohr I, we have:

$$[\text{Change in slope}]_{AB} = \left[\text{Area of } \frac{M}{EI} \text{ diagram} \right]_{AB}$$

$$\theta_B - \theta_A = \frac{1}{2} \cdot L \cdot \frac{PL}{EI}$$

Since the rotation at A is zero (it is a fixed support), i.e. $\theta_A = 0$, we have:

$$\theta_B = \frac{PL^2}{2EI}$$

2.3 Mohr's Second Theorem (Mohr II)

Development

From the main diagram, we can see that:

$$d\Delta = x \cdot d\theta$$

But, as we know from previous,

$$d\theta = \frac{M}{EI} \cdot dx$$

Thus:

$$d\Delta = \frac{M}{EI} \cdot x \cdot dx$$

And so for the portion AB , we have:

$$\begin{aligned} \int_A^B d\Delta &= \int_A^B \frac{M}{EI} \cdot x \cdot dx \\ \Delta_{BA} &= \left[\int_A^B \frac{M}{EI} \cdot dx \right] \bar{x} \\ &= \text{First moment of } \frac{M}{EI} \text{ diagram about } B \end{aligned}$$

This is easily interpreted as:

$$\left[\begin{array}{c} \text{Vertical} \\ \text{Intercept} \end{array} \right]_{BA} = \left[\begin{array}{c} \text{Area of} \\ \frac{M}{EI} \text{ diagram} \end{array} \right]_{BA} \times \left[\begin{array}{c} \text{Distance from } B \text{ to centroid} \\ \text{of } \left(\frac{M}{EI} \right)_{BA} \text{ diagram} \end{array} \right]$$

This is Mohr's Second Theorem (Mohr II):

For an originally straight beam, subject to bending moment, the vertical intercept between one terminal and the tangent to the curve of another terminal is the first moment of the curvature diagram about the terminal where the intercept is measured.

There are two crucial things to note from this definition:

- Vertical intercept is *not* deflection; look again at the fundamental diagram – it is the distance from the deformed position of the beam to the tangent of the deformed shape of the beam at another location. That is:

$$\Delta \neq \delta$$

- The moment of the curvature diagram must be taken about the point where the vertical intercept is required. That is:

$$\Delta_{BA} \neq \Delta_{AB}$$

Example 2

For the cantilever beam, we can find the deflection at B since the produced tangent at A is horizontal, i.e. $\theta_A = 0$. Thus it can be used to measure deflections from:

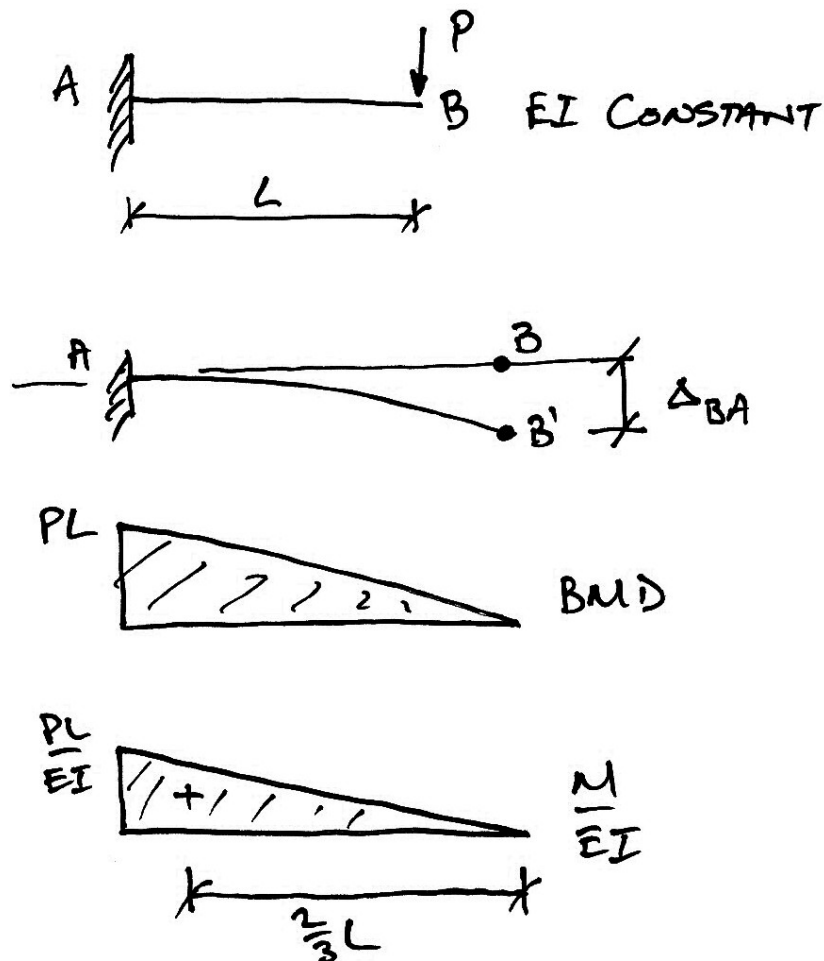

Thus, from Mohr II, we have:

$$\Delta_{BA} = \left[\frac{1}{2} \cdot L \cdot \frac{PL}{EI} \right] \left[\frac{2L}{3} \right]$$

And so the deflection at B is:

$$\delta_B = \frac{PL^3}{3EI}$$

2.4 Area Properties

These are well known for triangular and rectangular areas. For parabolic areas we have:

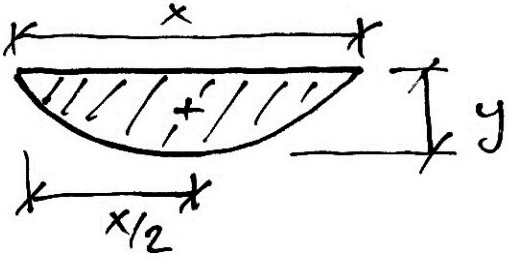
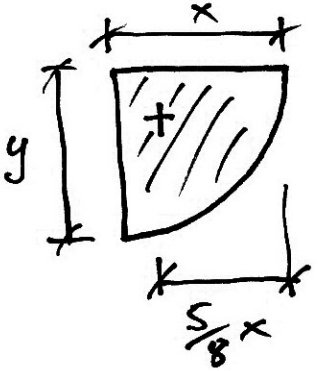
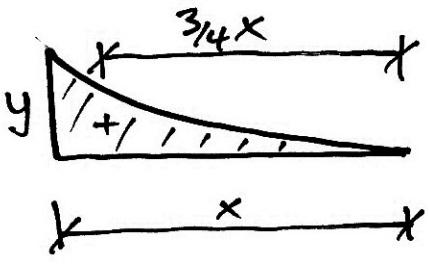
Shape	Area	Centroid
	$A = \frac{2}{3}xy$	$\bar{x} = \frac{1}{2}x$
	$A = \frac{2}{3}xy$	$\bar{x} = \frac{5}{8}x$
	$A = \frac{1}{3}xy$	$\bar{x} = \frac{3}{4}x$

3. Application to Determinate Structures

3.1 Basic Examples

Example 3

For the following beam, find δ_B , δ_C , θ_B and θ_C given the section dimensions shown and $E = 10 \text{ kN/mm}^2$.

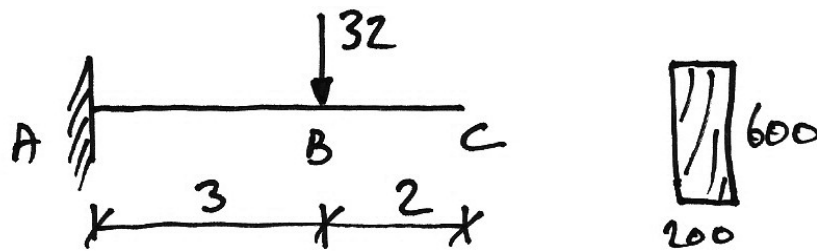

To be done in class.

Example 4

For the following simply-supported beam, we can find the rotation at A using Mohr's Second Theorem. The deflected shape diagram is used to identify relationships between vertical intercepts and rotations:

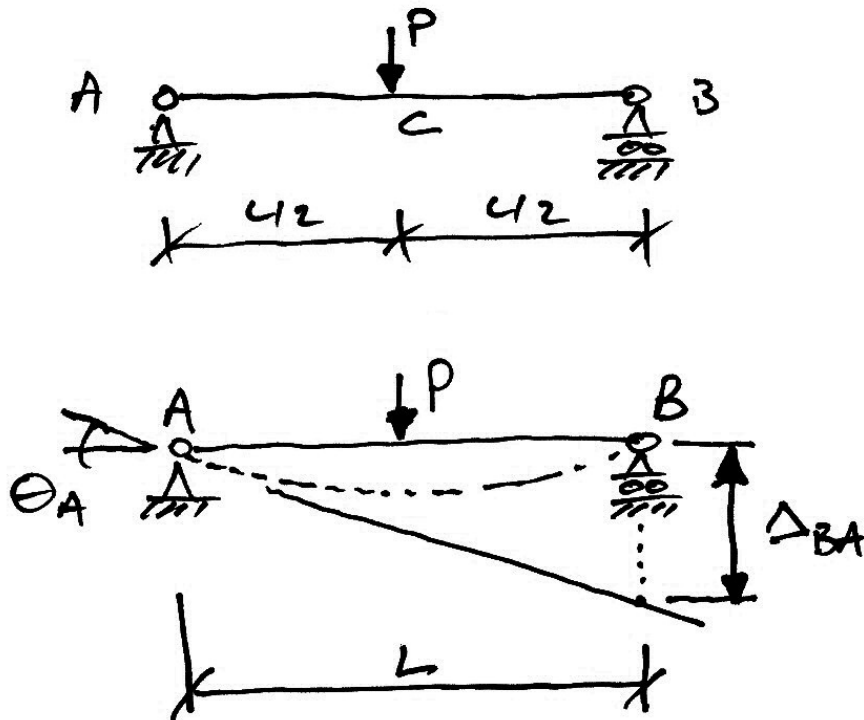

The key to the solution here is that we can calculate Δ_{BA} using Mohr II but from the diagram we can see that we can use the formula $S = R\theta$ for small angles:

$$\Delta_{BA} = L \cdot \theta_A$$

Therefore once we know Δ_{BA} using Mohr II, we can find $\theta_A = \Delta_{BA}/L$.

To calculate Δ_{BA} using Mohr II we need the bending moment and curvature diagrams:

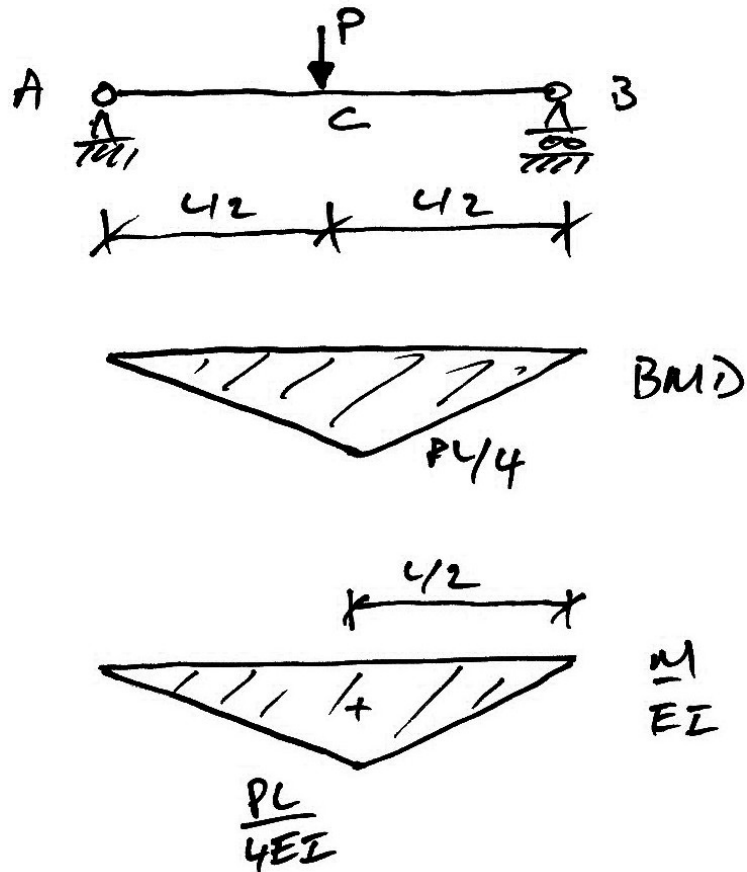

Thus, from Mohr II, we have:

$$\Delta_{BA} = \left[\frac{1}{2} \cdot L \cdot \frac{PL}{4EI} \right] \left[\frac{L}{2} \right]$$

$$= \frac{PL^3}{16EI}$$

But, $\Delta_{BA} = L \cdot \theta_A$ and so we have:

$$\theta_A = \frac{\Delta_{BA}}{L}$$

$$= \frac{PL^2}{16EI}$$

3.2 Finding Deflections

General Procedure

To find the deflection at any location x from a support use the following relationships between rotations and vertical intercepts:

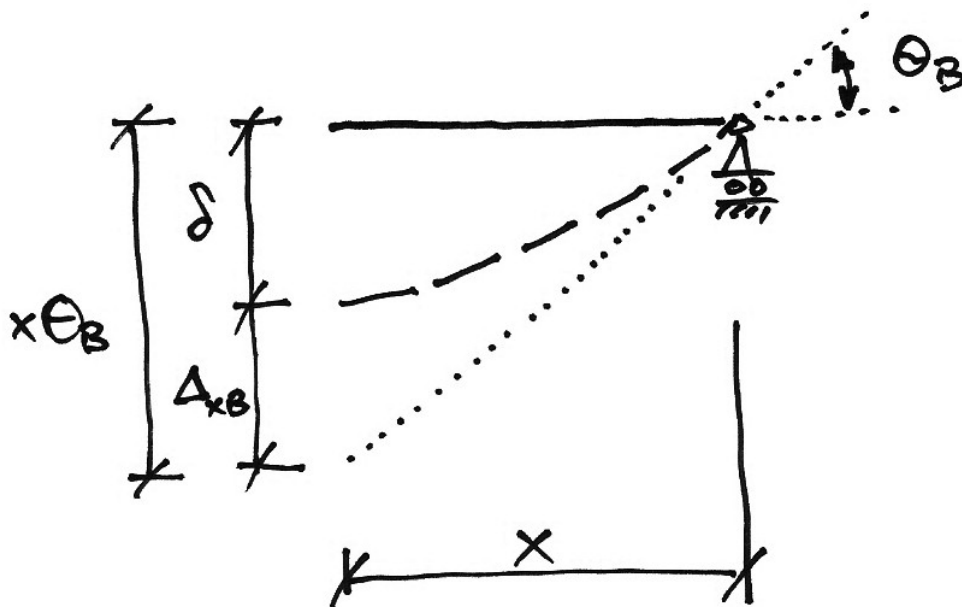

Thus we:

1. Find the rotation at the support using Mohr II as before;
2. For the location x , and from the diagram we have:

$$\delta_x = x \cdot \theta_B - \Delta_{xB}$$

Maximum Deflection

To find the maximum deflection we first need to find the location at which this occurs. We know from beam theory that:

$$\delta = \frac{d\theta}{dx}$$

Hence, from basic calculus, the maximum deflection occurs at a rotation, $\theta = 0$:

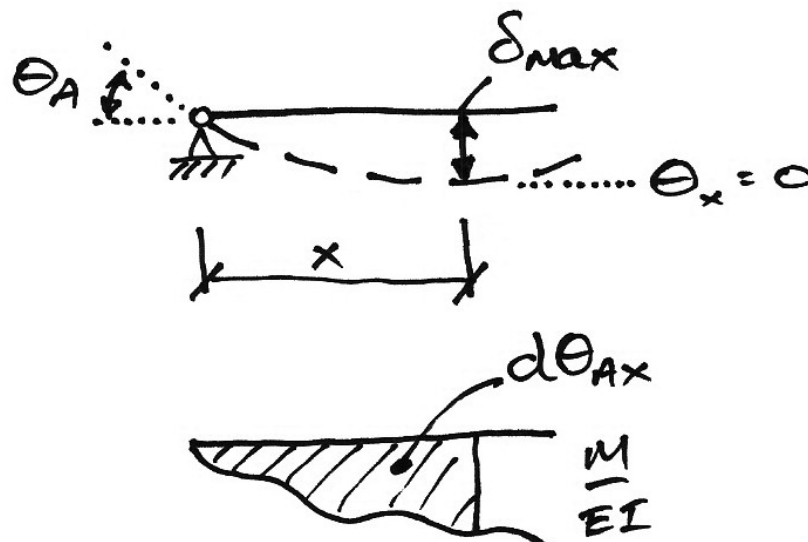

To find where the rotation is zero:

1. Calculate a rotation at some point, say support A, using Mohr II say;
2. Using Mohr I, determine at what distance from the point of known rotation (A) the change in rotation (Mohr I), $d\theta_{Ax}$ equals the known rotation (θ_A).
3. This is the point of maximum deflection since:

$$\theta_A - d\theta_{Ax} = \theta_A - \theta_A = 0$$

Example 5

For the following beam of constant EI :

- (a) Determine θ_A , θ_B and δ_C ;
- (b) What is the maximum deflection and where is it located?

Give your answers in terms of EI .

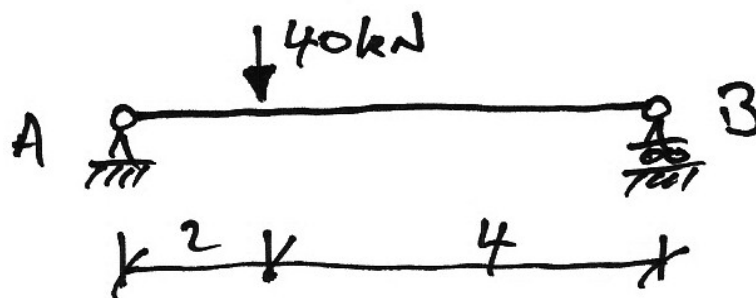

The first step is to determine the BMD and draw the deflected shape diagram with rotations and tangents indicated:

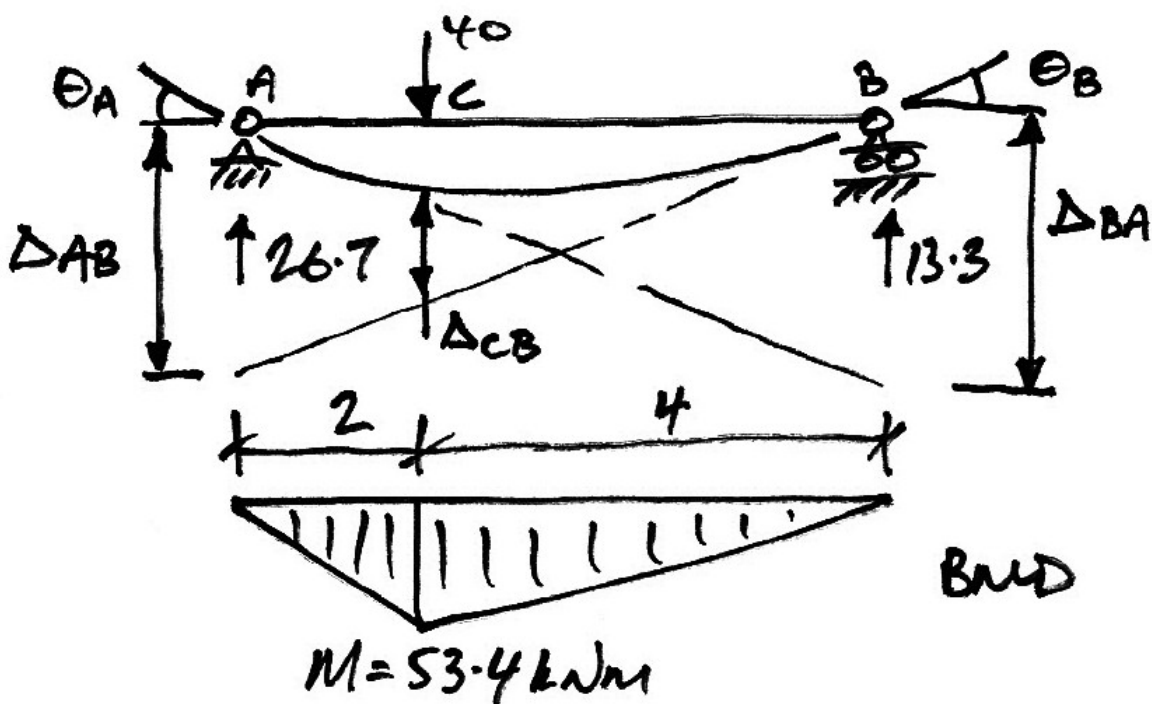

Rotations at A and B

To calculate the rotations, we need to calculate the vertical intercepts and use the fact that the intercept is length times rotation. Thus, for the rotation at B:

$$\begin{aligned}
 EI\Delta_{AB} &= \left(\frac{2}{3} \cdot 2\right) \left(\frac{1}{2} \cdot 2 \cdot M\right) + \left(2 + \frac{4}{3}\right) \left(\frac{1}{2} \cdot 4 \cdot M\right) \\
 &= M \left(\frac{4}{3} + \frac{20}{3}\right) \\
 &= 8M \\
 \therefore \Delta_{AB} &= \frac{8M}{EI}
 \end{aligned}$$

But, we also know that $\Delta_{AB} = 6\theta_B$. Hence:

$$\begin{aligned}
 6\theta_B &= \frac{8M}{EI} \\
 \therefore \theta_B &= \frac{4M}{3EI} = 1.33 \frac{M}{EI}
 \end{aligned}$$

Similarly for the rotation at A:

$$\begin{aligned}
 EI\Delta_{BA} &= \left(\frac{2}{3} \cdot 4\right) \left(\frac{1}{2} \cdot 4 \cdot M\right) + \left(4 + \frac{1}{3} \cdot 2\right) \left(\frac{1}{2} \cdot 2 \cdot M\right) \\
 &= M \left(\frac{16}{3} + \frac{14}{3}\right) \\
 &= 10M \\
 \therefore \Delta_{BA} &= \frac{10M}{EI}
 \end{aligned}$$

But, we also know that $\Delta_{BA} = 6\theta_A$ and so:

$$6\theta_A = \frac{10M}{EI}$$

$$\therefore \theta_A = \frac{5M}{3EI} = 1.67 \frac{M}{EI}$$

Deflection at C

To find the deflection at C, we use the vertical intercept Δ_{CB} and θ_B :

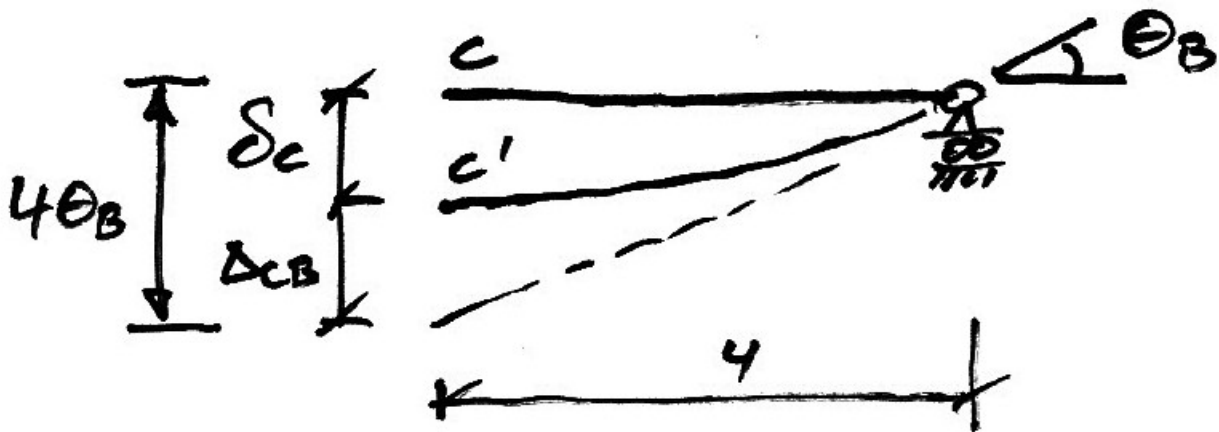

From the figure, we see:

$$\delta_c = 4\theta_B - \Delta_{CB}$$

And so from the BMD and rotation at B:

$$EI\delta_c = 4(1.33M) - \left(\frac{1}{2} \cdot 4 \cdot M\right) \left(\frac{4}{3}\right)$$

$$\therefore \delta_c = 2.665 \frac{M}{EI}$$

Maximum Deflection

The first step in finding the maximum deflection is to locate it. We know two things:

1. Maximum deflection occurs where there is zero rotation;
2. Maximum deflection is always close to the centre of the span.

Based on these facts, we work with Mohr I to find the point of zero rotation, which will be located between B and C , as follows:

$$\text{Change in rotation} = \theta_B - 0 = \theta_B$$

But since we know that the change in rotation is also the area of the M/EI diagram we need to find the point x where the area of the M/EI diagram is equal to θ_B :

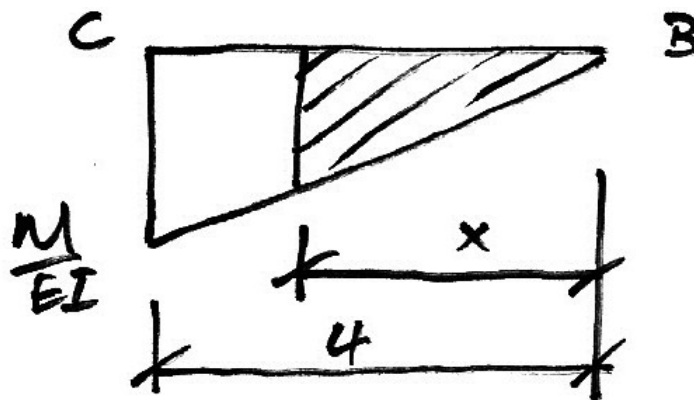

Thus:

$$EI(\theta_B - 0) = \left(M \cdot \frac{x}{4} \right) \cdot \frac{1}{2} \cdot x$$

$$EI\theta_B = M \frac{x^2}{8}$$

But we know that $\theta_B = 1.33 \frac{M}{EI}$, hence:

$$EI \left(1.33 \frac{M}{EI} \right) = M \frac{x^2}{8}$$

$$x^2 = 10.66$$

$$x = 3.265 \text{ m from } B \text{ or } 2.735 \text{ m from } A$$

So we can see that the maximum deflection is 265 mm shifted from the centre of the beam towards the load. Once we know where the maximum deflection is, we can calculate it based on the following diagram:

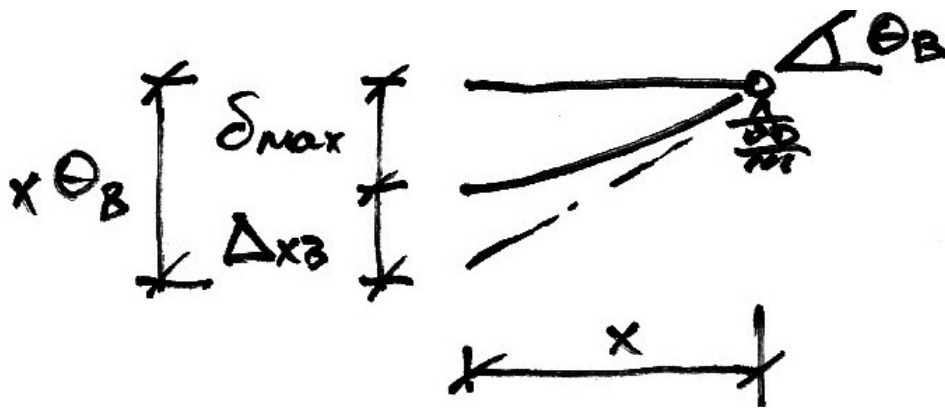

Thus:

$$\delta_{\max} = x\theta_B - \Delta_{xB}$$

$$EI\delta_{\max} = x(1.33M) - \left(M \frac{x^2}{8} \right) \left(\frac{x}{3} \right)$$

$$= M(4.342 - 1.450)$$

$$\delta_{\max} = 2.892 \frac{M}{EI}$$

And since $M = 53.4 \text{ kNm}$, $\delta_{\max} = \frac{154.4}{EI}$.

3.3 Problems

1. For the beam of Example 3, using only Mohr's First Theorem, show that the rotation at support B is equal in magnitude but not direction to that at A .
2. For the following beam, of dimensions $b=150$ mm and $d=225$ mm and $E=10$ kN/mm², show that $\theta_B = 7 \times 10^{-4}$ rads and $\delta_B = 9.36$ mm.

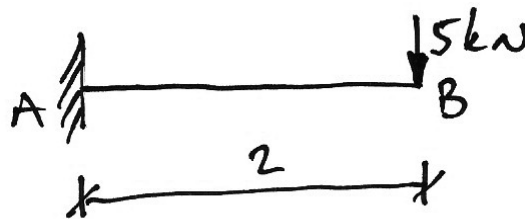

3. For a cantilever AB of length L and stiffness EI , subjected to a UDL, show that:

$$\theta_B = \frac{wL^3}{6EI}; \quad \delta_B = \frac{wL^4}{8EI}$$

4. For a simply-supported beam AB with a point load at mid span (C), show that:

$$\delta_C = \frac{PL^3}{48EI}$$

5. For a simply-supported beam AB of length L and stiffness EI , subjected to a UDL, show that:

$$\theta_A = \frac{wL^3}{24EI}; \quad \theta_B = -\frac{wL^3}{24EI}; \quad \delta_C = \frac{5wL^4}{384EI}$$

4. Application to Indeterminate Structures

4.1 *Basis of Approach*

Using the principle of superposition we will separate indeterminate structures into a primary and reactant structures.

For these structures we will calculate the deflections at a point for which the deflection is known in the original structure.

We will then use compatibility of displacement to equate the two calculated deflections to the known deflection in the original structure.

Doing so will yield the value of the redundant reaction chosen for the reactant structure.

Once this is known all other load effects (bending, shear, deflections, rotations) can be calculated.

See the handout on Compatibility of Displacement and the Principle of Superposition for more on this approach.

4.2 Example 6: Propped Cantilever

For the following prismatic beam, find the maximum deflection in span AB and the deflection at C in terms of EI .

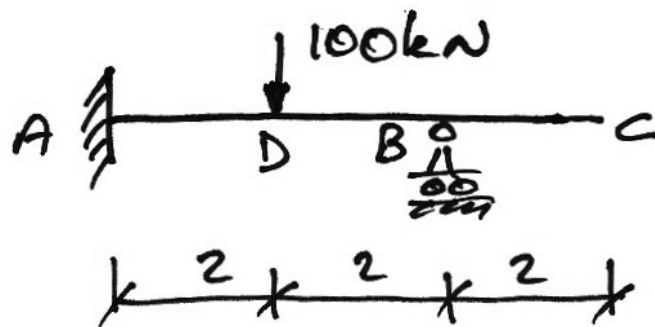

Find the reaction at B

Since this is an indeterminate structure, we first need to solve for one of the unknown reactions. Choosing V_B as our redundant reaction, using the principle of superposition, we can split the structure up as shown:

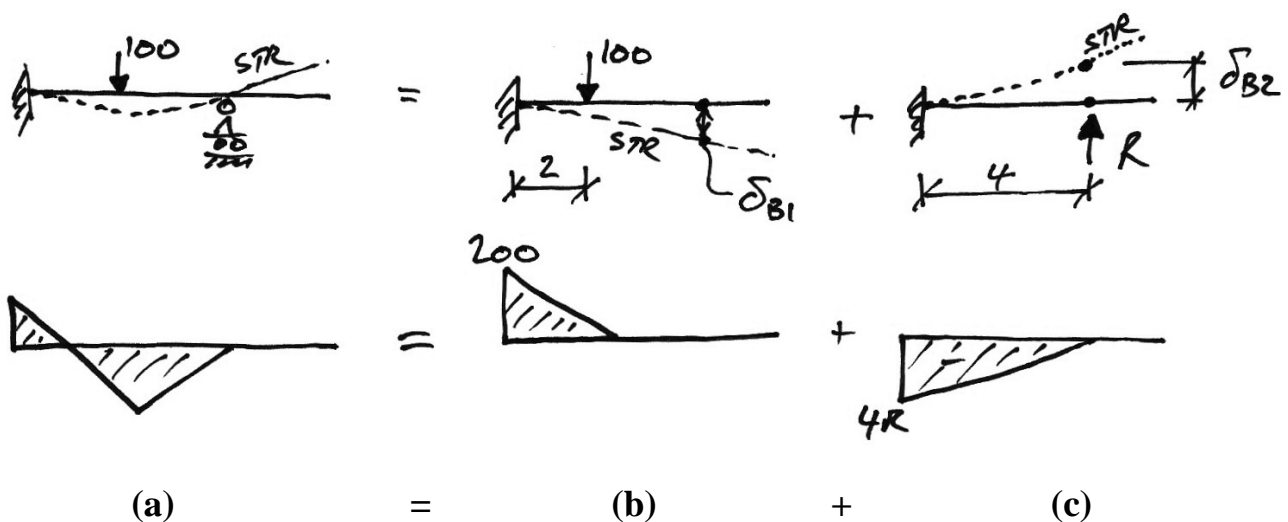

In which R is the value of the chosen redundant.

In the final structure (a) we know that the deflection at B , δ_B , must be zero as it is a roller support. So from the BMD that results from the superposition of structures (b) and (c) we can calculate δ_B in terms of R and solve since $\delta_B = 0$.

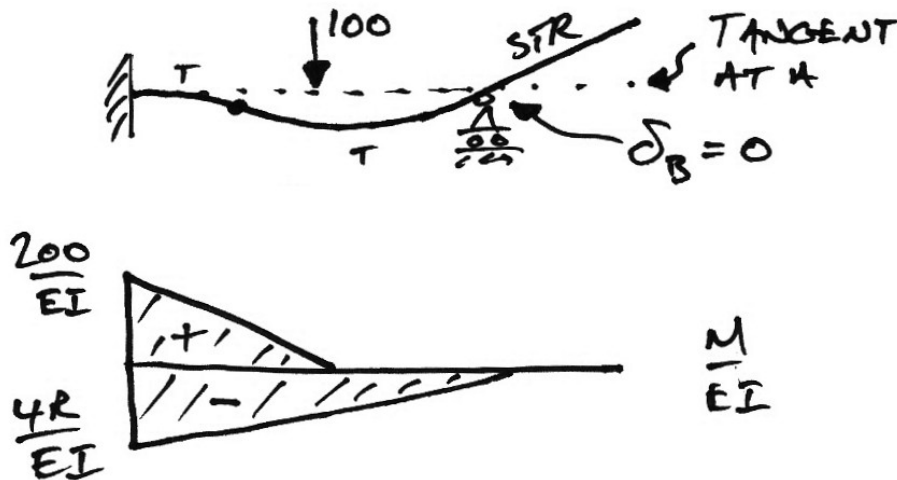

We have from Mohr II:

$$\begin{aligned}
 EI\Delta_{BA} &= \left[\left(\frac{1}{2} \cdot 2 \cdot 200 \right) \left(2 + \frac{2}{3} \cdot 2 \right) \right]_{(b)} + \left[- \left(\frac{1}{2} \cdot 4 \cdot 4R \right) \left(\frac{2}{3} \cdot 4 \right) \right]_{(c)} \\
 &= \frac{2000}{3} - \frac{64}{3}R \\
 &= \frac{1}{3}(2000 - 64R)
 \end{aligned}$$

But since $\theta_A = 0$, $\delta_B = \Delta_{BA}$ and so we have:

$$\begin{aligned}
 EI\Delta_{BA} &= 0 \\
 \frac{1}{3}(2000 - 64R) &= 0 \\
 64R &= 2000 \\
 R &= +31.25 \text{ kN}
 \end{aligned}$$

The positive sign for R means that the direction we originally assumed for it (upwards) was correct.

At this point the final BMD can be drawn but since its shape would be more complex we continue to operate using the structure (b) and (c) BMDs.

Find the location of the maximum deflection

This is the next step in determining the maximum deflection in span AB . Using the knowledge that the tangent at A is horizontal, i.e. $\theta_A = 0$, we look for the distance x from A that satisfies:

$$d\theta_{Ax} = \theta_A - \theta_x = 0$$

By inspection on the deflected shape, it is apparent that the maximum deflection occurs to the right of the point load. Hence we have the following:

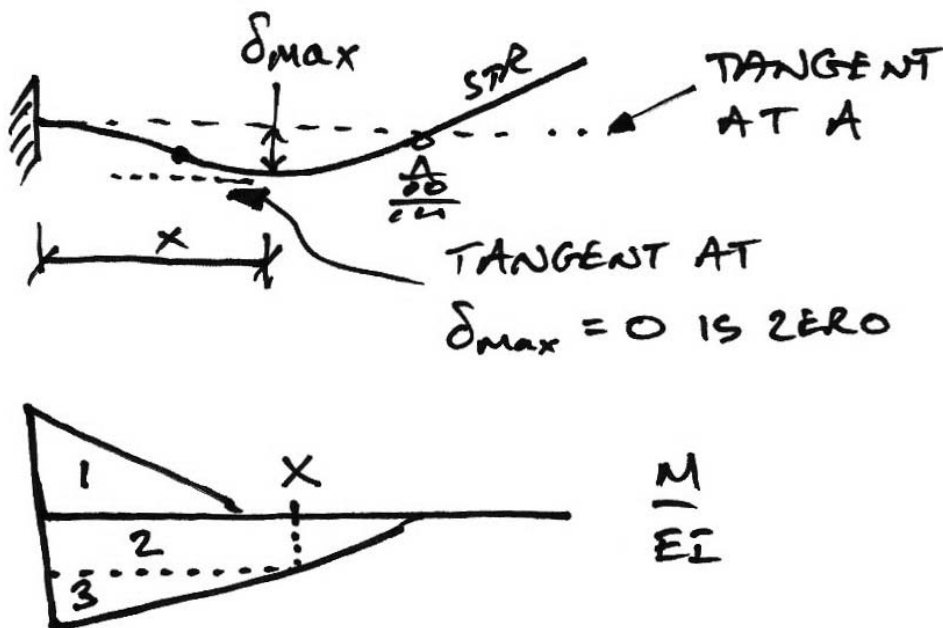

So using Mohr I we calculate the change in rotation by finding the area of the curvature diagram between A and x. The diagram is split for ease:

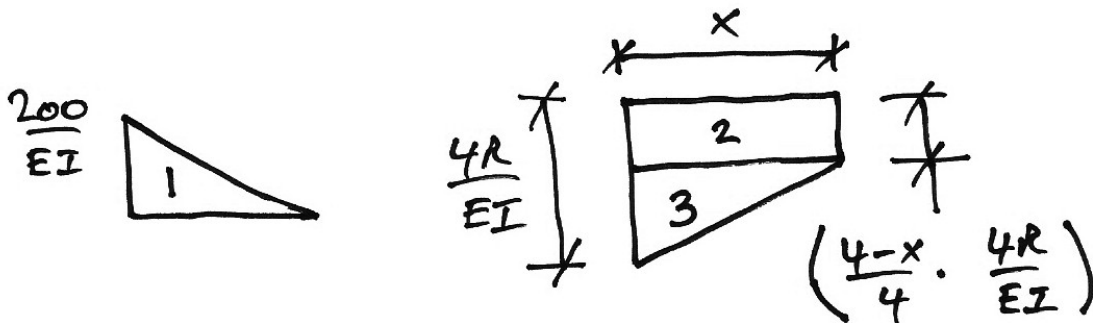

The Area 1 is trivial:

$$A_1 = \frac{1}{2} \cdot 2 \cdot \frac{200}{EI} = \frac{200}{EI}$$

For Area 2, we need the height first which is:

$$h_2 = \frac{4-x}{4} \cdot \frac{4R}{EI} = \frac{4 \cdot 125 - 125x}{4EI} = \frac{125}{EI} - \frac{125}{EI}x$$

And so the area itself is:

$$A_2 = x \cdot \left[\frac{125}{EI} - \frac{125}{EI}x \right]$$

For Area 3 the height is:

$$h_3 = \frac{125}{EI} - \left[\frac{125}{EI} - \frac{125}{EI}x \right] = \frac{125}{EI}x$$

And so the area is:

$$A_2 = \frac{1}{2} \cdot x \cdot \frac{125}{EI} x$$

Being careful of the signs for the curvatures, the total area is:

$$\begin{aligned} EId\theta_{Ax} &= -A_1 + A_2 + A_3 \\ &= -200 + x \left(125 - \frac{125}{4} x \right) + \frac{125}{8} x^2 \\ &= \left(\frac{125}{8} - \frac{125}{4} \right) x^2 + 125x - 200 \end{aligned}$$

Setting this equal to zero to find the location of the maximum deflection, we have:

$$\begin{aligned} -\frac{125}{8} x^2 + 125x - 200 &= 0 \\ 5x^2 - 40x + 64 &= 0 \end{aligned}$$

Thus, $x = 5.89$ m or $x = 2.21$ m. Since we are dealing with the portion AB , $x = 2.21$ m.

Find the maximum deflection

Since the tangent at both A and x are horizontal, i.e. $\theta_A = 0$ and $\theta_x = 0$, the deflection is given by:

$$\delta_{\max} = \Delta_{xA}$$

Using Mohr II and Areas 1, 2 and 3 as previous, we have:

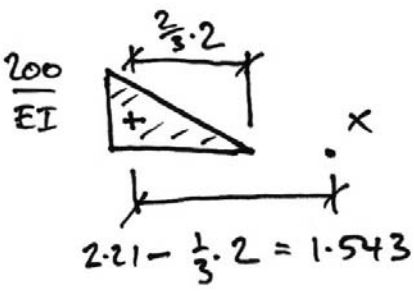
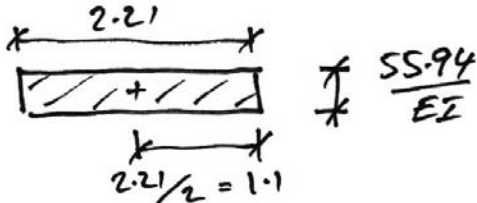
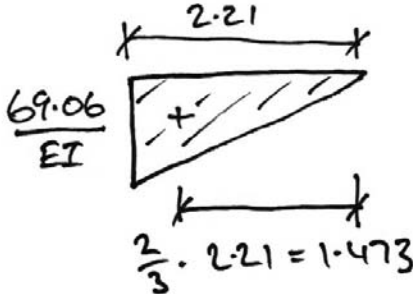
<p>Area 1</p>		$A_1 \bar{x}_1 = -\frac{200}{EI} \cdot 1.543$ $= -\frac{308.67}{EI}$
<p>Area 2</p>		$h_2 = \frac{4 - 2.21}{4} \cdot \frac{4R}{EI} = \frac{55.94}{EI}$ $A_2 \bar{x}_2 = 2.21 \cdot \frac{55.94}{EI} \cdot \frac{2.21}{2}$ $= \frac{136.61}{EI}$
<p>Area 3</p>		$h_3 = 2.21 \cdot \frac{125}{EI} = \frac{69.06}{EI}$ $A_3 \bar{x}_3 = \left[\frac{1}{2} \cdot 2.21 \cdot \frac{69.06}{EI} \right] \cdot 1.473$ $= \frac{112.43}{EI}$

Thus:

$$EI \Delta_{xB} = EI \delta_{\max} = -308.67 + 136.61 + 112.43$$

$$\Rightarrow \delta_{\max} = \frac{-59.63}{EI}$$

The negative sign indicates that the negative bending moment diagram dominates, i.e. the hogging of the cantilever is pushing the deflection downwards.

Find the deflection at C

For the deflection at C we again use the fact that $\theta_A = 0$ with Mohr II to give:

$$\delta_C = \Delta_{CA}$$

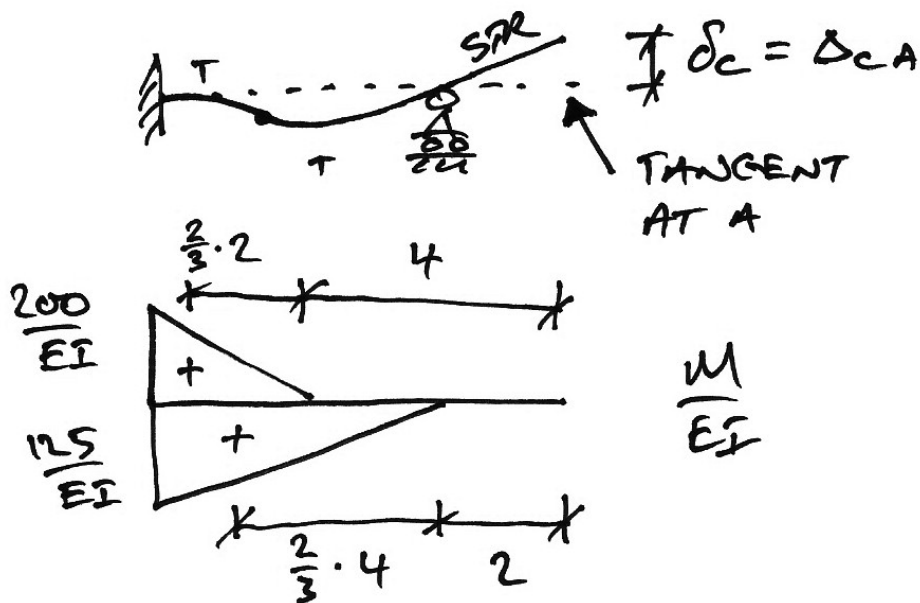

From the diagram we have:

$$EI\Delta_{CA} = -\left(\frac{1}{2} \cdot 2 \cdot 200\right)\left(\frac{4}{3} + 4\right) + \left(\frac{1}{2} \cdot 4 \cdot 125\right)\left(2 + \frac{8}{3}\right)$$

$$\delta_C = \frac{+100}{EI}$$

The positive sign indicates that the positive bending moment region dominates and so the deflection is upwards.

4.3 Example 7: 2-Span Beam

For the following beam of constant EI , using Mohr's theorems:

- (a) Draw the bending moment diagram;
- (b) Determine, δ_D and δ_E ;

Give your answers in terms of EI .

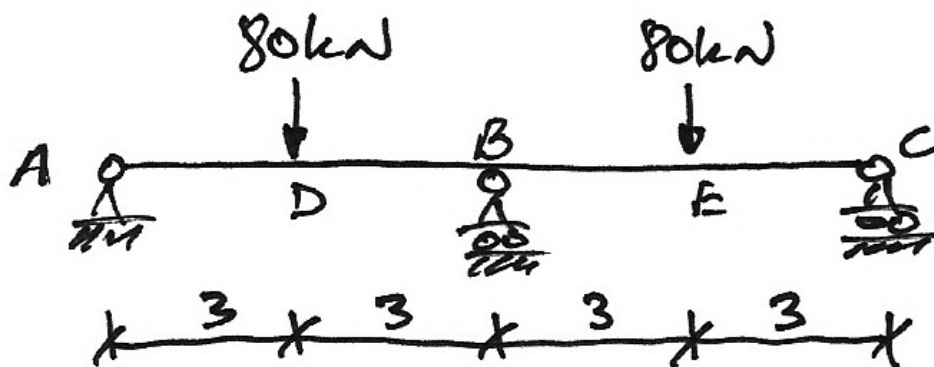

In the last example we knew the rotation at A and this made finding the deflection at the redundant support relatively easy. Once again we will choose a redundant support, in this case the support at B.

In the present example, we do not know the rotation at A – it must be calculated – and so finding the deflection at B is more involved. We can certainly use compatibility of displacement at B, but in doing so we will have to calculate the vertical intercept from B to A, Δ_{BA} , twice. Therefore, to save effort, we use Δ_{BA} as the measure which we apply compatibility of displacement to. We will calculate Δ_{BA} through calculation of θ_A (and using the small angle approximation) and through direct calculation from the bending moment diagram. We will then have an equation in R which can be solved.

Rotation at A

Breaking the structure up into primary and redundant structures:

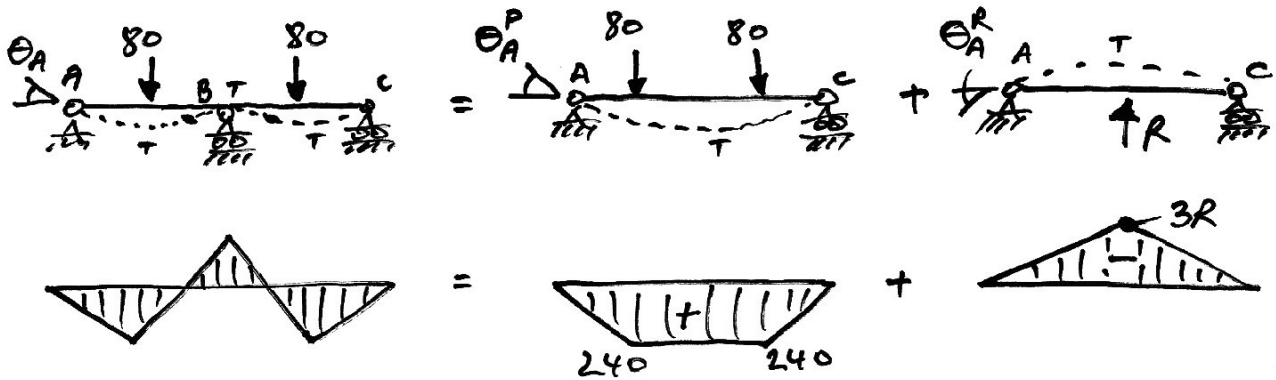

So we can see that the final rotation at A is:

$$\theta_A = \theta_A^P + \theta_A^R$$

To find the rotation at A in the primary structure, consider the following:

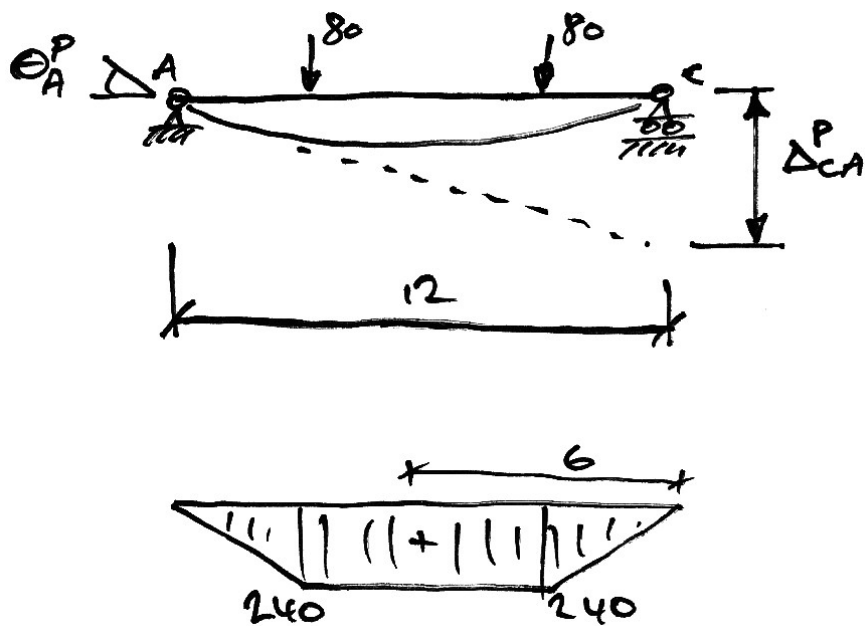

By Mohr II we have:

$$EI\Delta_{CA} = (240 \cdot 9)(6) = 12960$$

But we know, from the small angle approximation, $\Delta_{CA} = 12\theta_A$, hence:

$$EI\theta_A^p = \frac{\Delta_{CA}}{12} = \frac{12960}{12} = 1080$$

$$\therefore \theta_A^p = \frac{1080}{EI}$$

To find the rotation at A for the reactant structure, we have:

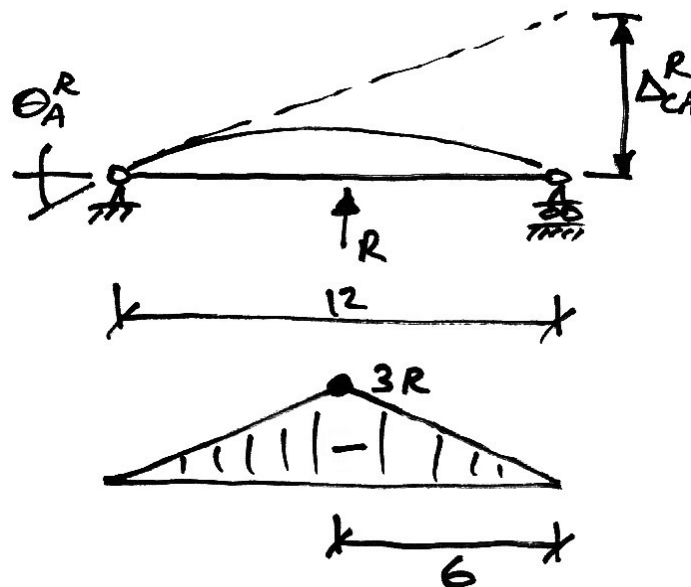

$$EI\Delta_{CA} = \left(\frac{1}{2} \cdot 12 \cdot 3R \right) (6) = 108R$$

$$\Delta_{CA} = 12\theta_A$$

$$EI\theta_A^R = \frac{\Delta_{CA}}{12} = \frac{108R}{12} = 9R$$

$$\therefore \theta_A^R = -\frac{9R}{EI}$$

Notice that we assign a negative sign to the reactant rotation at A since it is in the opposite sense to the primary rotation (which we expect to dominate).

Thus, we have:

$$\begin{aligned}\theta_A &= \theta_A^P + \theta_A^R \\ &= \frac{1080}{EI} - \frac{9R}{EI}\end{aligned}$$

Vertical Intercept from B to A

The second part of the calculation is to find Δ_{BA} directly from calculation of the curvature diagram:

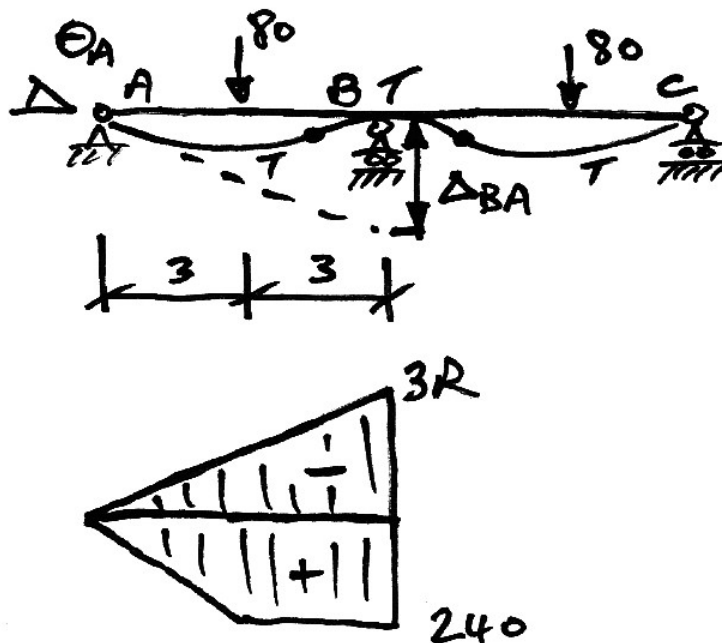

Thus we have:

$$EI\Delta_{BA} = -\left(\frac{1}{2} \cdot 6 \cdot 3R\right)\left(\frac{1}{3} \cdot 6\right) + (240 \cdot 3)\left(\frac{3}{2}\right) + \left(\frac{1}{2} \cdot 3 \cdot 240\right)\left(3 + \frac{3}{3}\right)$$

$$EI\Delta_{BA} = -18R + 1080 + 1440$$

$$\therefore \Delta_{BA} = \frac{2520 - 18R}{EI}$$

Solution for R

Now we recognize that $\Delta_{BA} = 6\theta_A$ by compatibility of displacement, and so:

$$\frac{2520 - 18R}{EI} = 6\left(\frac{1080}{EI} - \frac{9R}{EI}\right)$$

$$2520 - 18R = 6(1080 - 9R)$$

$$36R = 3960$$

$$R = 110 \text{ kN}$$

Solution to Part (a)

With this we can immediately solve for the final bending moment diagram by superposition of the primary and reactant BMDs:

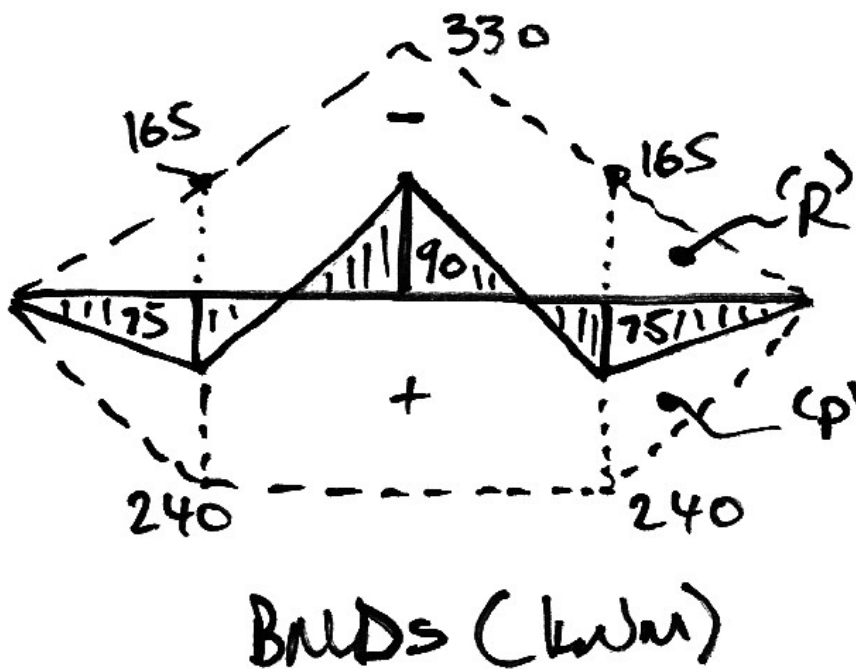

Solution to Part (b)

We are asked to calculate the deflection at D and E . However, since the beam is symmetrical $\delta_D = \delta_E$ and so we need only calculate one of them – say δ_D . Using the (now standard) diagram for the calculation of deflection:

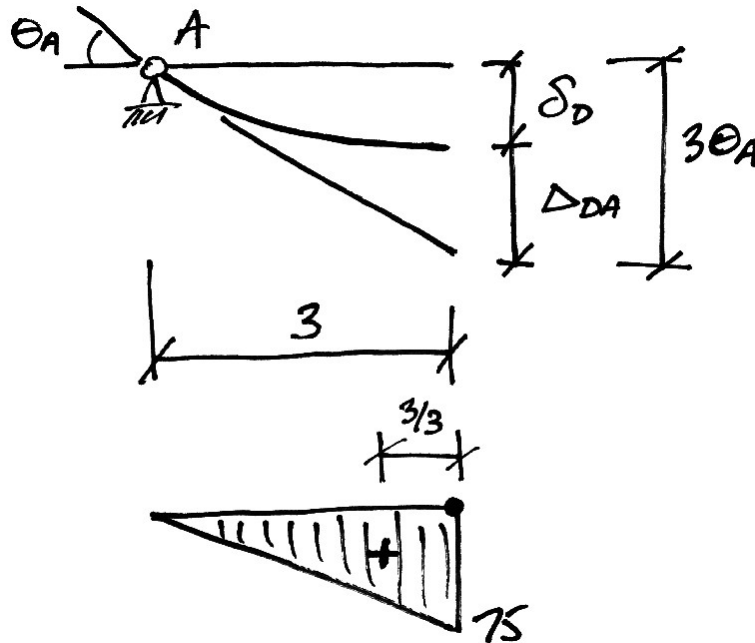

$$\theta_A = \frac{1080}{EI} - \frac{9(110)}{EI} = \frac{90}{EI}$$

$$EI\Delta_{DA} = \left(\frac{1}{3} \cdot 3 \cdot 75\right) \left(\frac{3}{3}\right) = 112.5$$

But $\delta_D = 3\theta_A - \Delta_{DA}$, thus:

$$\begin{aligned} EI\delta_D &= 3(90) - 112.5 \\ &= 157.5 \end{aligned}$$

$$\delta_D = \delta_E = \frac{157.5}{EI}$$

4.4 Example 8: Simple Frame

For the following frame of constant $EI = 40 \text{ MNm}^2$, using Mohr's theorems:

- (a) Draw the bending moment and shear force diagram;
- (b) Determine the horizontal deflection at E.

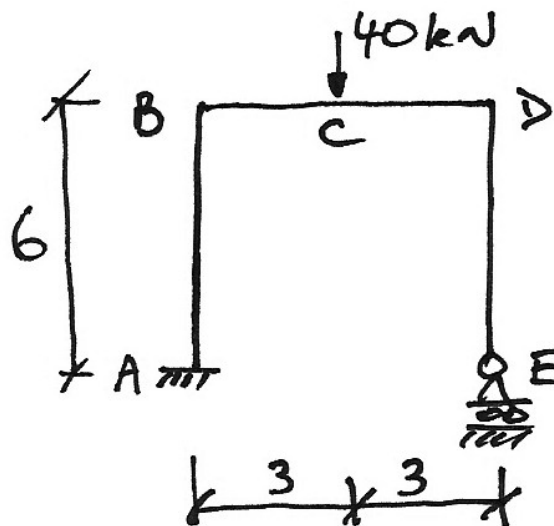

Part (a)

Solve for a Redundant

As with the beams, we split the structure into primary and reactant structures:

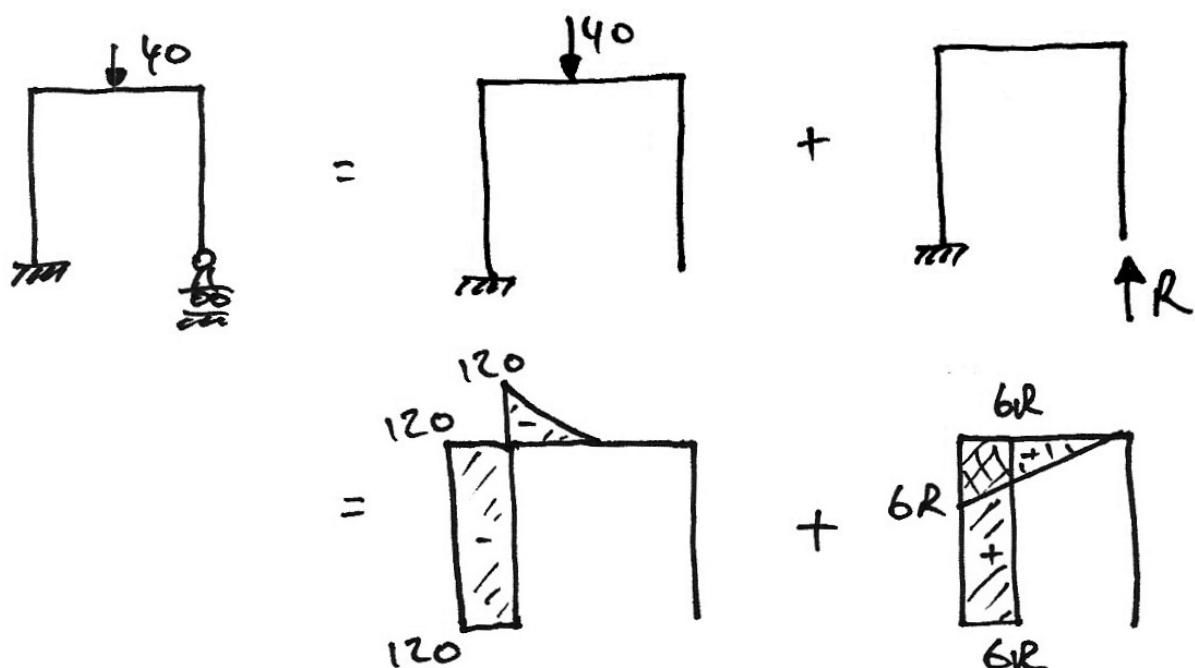

We also need to draw the deflected shape diagram of the original structure to identify displacements that we can use:

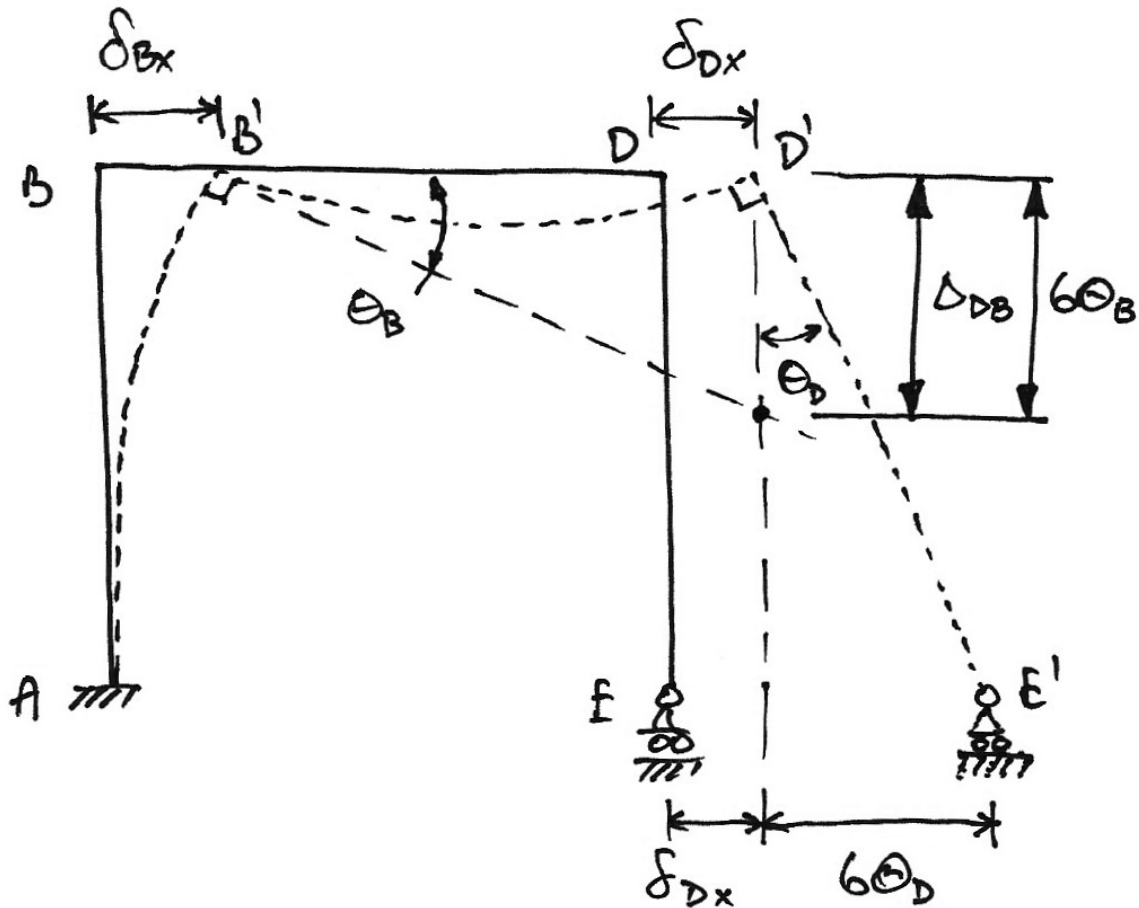

To solve for R we could use any known displacement. In this case we will use the vertical intercept Δ_{DB} as shown, because:

- We can determine Δ_{DB} for the original structure in terms of R using Mohr's Second Theorem;
- We see that $\Delta_{DB} = 6\theta_B$ and so using Mohr's First Theorem for the original structure we will find θ_B , again in terms of R ;
- We equate the two methods of calculating Δ_{DB} (both are in terms of R) and solve for R .

Find Δ_{DB} by Mohr II

Looking at the combined bending moment diagram, we have:

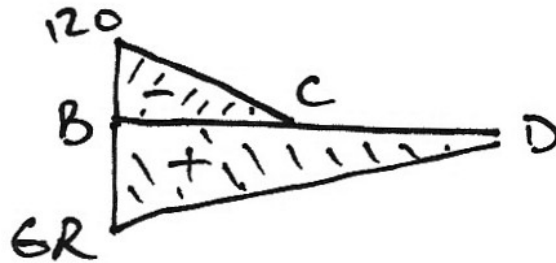

$$\begin{aligned}
 EI\Delta_{DB} &= \left[\frac{1}{2} \cdot 6 \cdot 6R \right] \cdot \left[\frac{2}{3} \cdot 6 \right] - \left[\frac{1}{2} \cdot 3 \cdot 120 \right] \cdot \left[3 + \frac{2}{3} \cdot 3 \right] \\
 &= 72R - 900
 \end{aligned}$$

Find θ_B by Mohr I

Since the tangent at A is vertical, the rotation at B will be the change in rotation from A to B:

$$\begin{aligned}
 d\theta_{BA} &= \theta_B - \theta_A \\
 &= \theta_B - 0 \\
 &= \theta_B \\
 &= \text{Area of } \left(\frac{M}{EI} \right)_{B \text{ to } A}
 \end{aligned}$$

Therefore, by Mohr I:

$$\begin{aligned}
 EI\theta_B &= \text{Area of } \left(\frac{M}{EI} \right)_{B \text{ to } A} \\
 &= 6 \cdot 6R - 120 \cdot 6 \\
 &= 36R - 720
 \end{aligned}$$

Equate and Solve for R

As identified previously:

$$\Delta_{DB} = 6\theta_B$$

$$72R - 900 = 6[36R - 720]$$

$$R = 18.13 \text{ kN}$$

Diagrams

Knowing R we can then solve for the reactions, bending moment and shear force diagrams. The results are:

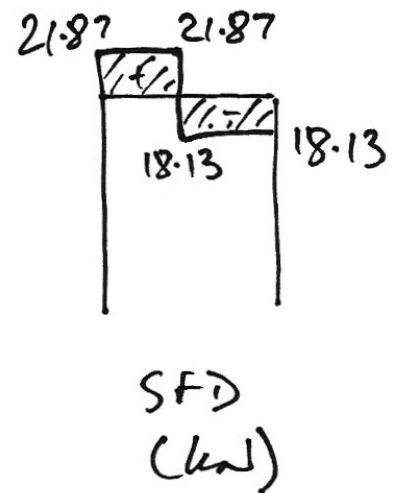
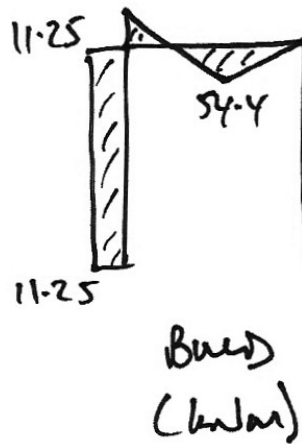
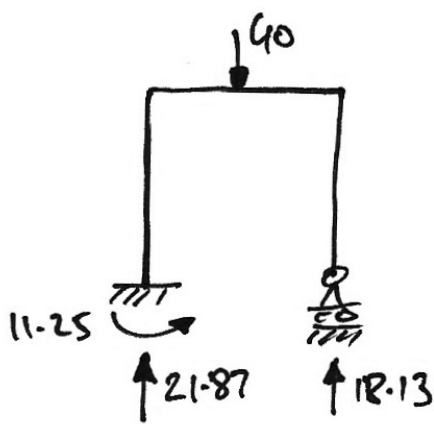

Part (b)

The movement at E is comprised of δ_{Dx} and $6\theta_D$ as shown in the deflection diagram.

These are found as:

- Since the length of member BD doesn't change, $\delta_{Dx} = \delta_{Bx}$. Further, by Mohr II,

$$\delta_{Bx} = \Delta_{BA};$$

- By Mohr I, $\theta_D = \theta_B - d\theta_{BD}$, that is, the rotation at D is the rotation at B minus the change in rotation from B to D :

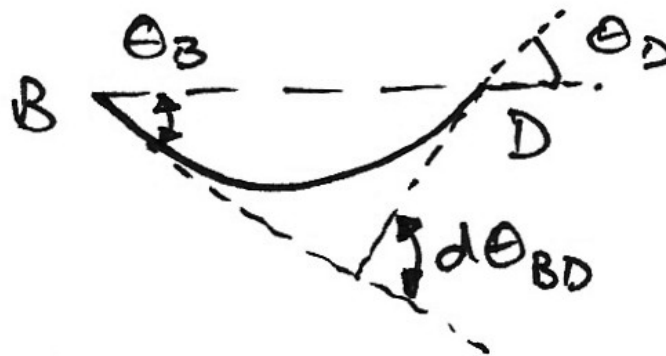

So we have:

$$\begin{aligned} EI\Delta_{BA} &= [6R \cdot 6][3] - [120 \cdot 6][3] \\ &= -202.5 \end{aligned}$$

$$\begin{aligned} EId\theta_{BD} &= \left[\frac{1}{2} \cdot 6R \cdot 6 \right] - \left[\frac{1}{2} \cdot 120 \cdot 3 \right] \\ &= 146.25 \end{aligned}$$

Notice that we still use the primary and reactant diagrams even though we know R . We do this because the shapes and distances are simpler to deal with.

From before we know:

$$EI\theta_B = 36R - 720 = 67.5$$

Thus, we have:

$$\begin{aligned}EI\theta_D &= EI\theta_B - d\theta_{BD} \\ &= 67.5 - 146.25 \\ &= -78.75\end{aligned}$$

The minus indicates that it is a rotation in opposite direction to that of θ_B which is clear from the previous diagram. Since we have taken account of the sense of the rotation, we are only interested in its absolute value. A similar argument applies to the minus sign for the deflection at B . Therefore:

$$\begin{aligned}\delta_{Ex} &= \delta_{Bx} + 6\theta_D \\ &= \frac{202.5}{EI} + 6 \cdot \frac{78.75}{EI} \\ &= \frac{675}{EI}\end{aligned}$$

Using $EI = 40 \text{ MNm}^2$ gives $\delta_{Ex} = 16.9 \text{ mm}$.

4.5 Example 9: Complex Frame

For the following frame of constant $EI = 40 \text{ MNm}^2$, using Mohr's theorems:

- Determine the reactions and draw the bending moment diagram;
- Determine the horizontal deflection at D .

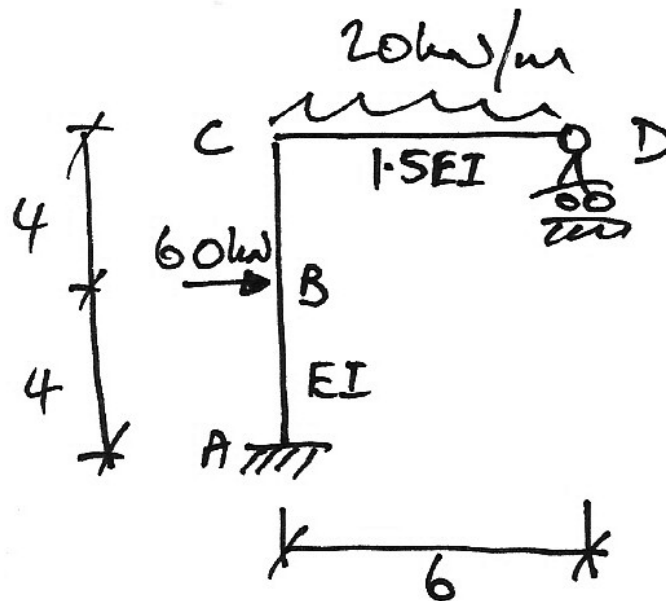

In this frame we have the following added complexities:

- There is a UDL and a point load which leads to a mix of parabolic, triangular and rectangular BMDs;
- There is a different EI value for different parts of the frame – we must take this into account when performing calculations and not just consider the M diagram but the M/EI diagram as per Mohr's Theorems.

Solve for a Redundant

As is usual, we split the frame up:

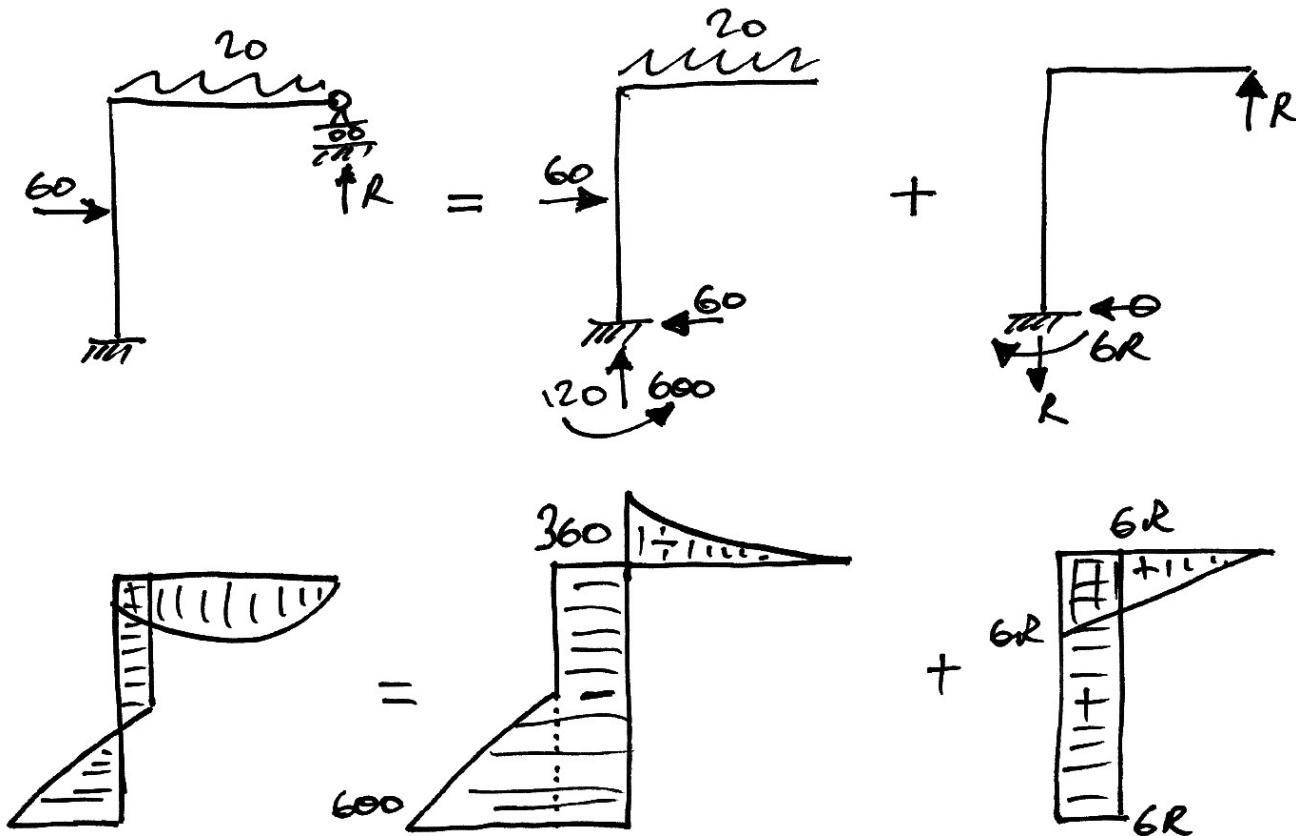

Next we draw the deflected shape diagram of the original structure to identify displacements that we can use:

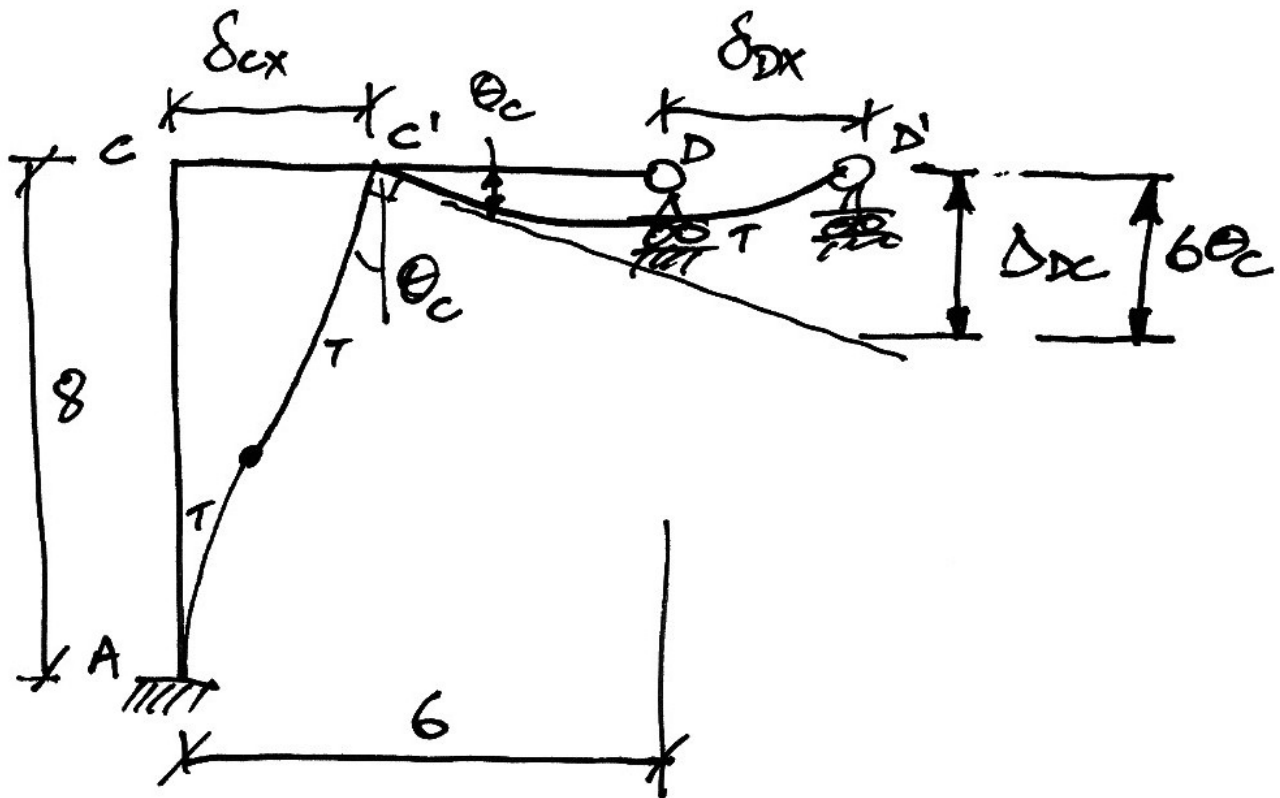

To solve for R we will use the vertical intercept Δ_{DC} as shown, because:

- We can determine Δ_{DC} for the original structure in terms of R using Mohr II;
- We see that $\Delta_{DC} = 6\theta_C$ and so using Mohr I for the original structure we will find θ_B , again in terms of R ;
- As usual, we equate the two methods of calculating Δ_{DC} (both are in terms of R) and solve for R .

The Rotation at C

To find the rotation at C, we must base our thoughts on the fact that we are only able to calculate the *change in rotation* from one point to another using Mohr I. Thus we identify that we know the rotation at A is zero – since it is a fixed support – and we can find the change in rotation from A to C, using Mohr I. Therefore:

$$\begin{aligned} d\theta_{A \text{ to } C} &= \theta_C - \theta_A \\ &= \theta_C - 0 \\ &= \theta_C \end{aligned}$$

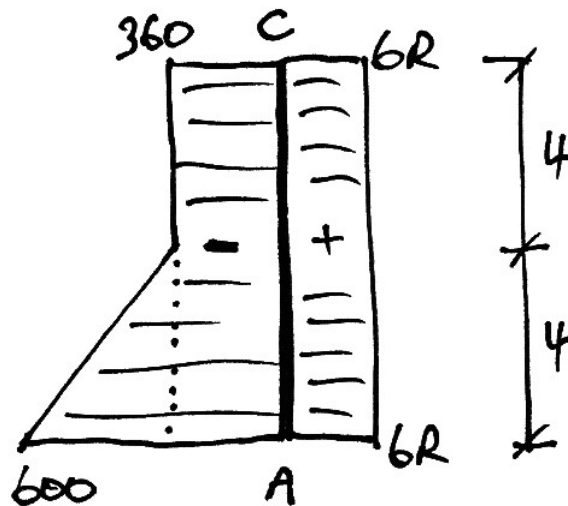

At this point we must recognize that since the frame is swaying to the right, the bending moment on the outside ‘dominates’ (as we saw for the maximum deflection calculation in Example 6). The change in rotation is the difference of the absolute values of the two diagrams, hence we have, from the figure, and from Mohr I:

$$\begin{aligned} EI d\theta_{A \text{ to } C} &= \left| (360 \cdot 8) + \left(\frac{1}{2} \cdot 240 \cdot 4 \right) \right| - |(6R \cdot 8)| \\ EI \theta_C &= 3360 - 48R \\ \therefore \theta_C &= \frac{3360 - 48R}{EI} \end{aligned}$$

The Vertical Intercept DC

Using Mohr II and from the figure we have:

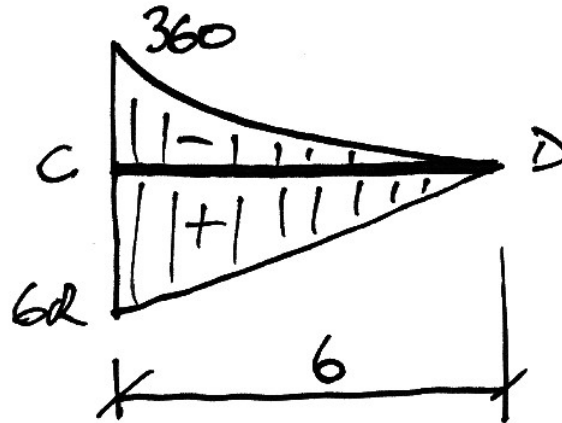

$$1.5EI\Delta_{DC} = \left[\left(\frac{1}{2} \cdot 6 \cdot 6R \right) \left(\frac{2}{3} \cdot 6 \right) \right] - \left[\left(\frac{1}{3} \cdot 6 \cdot 360 \right) \left(\frac{3}{4} \cdot 6 \right) \right]$$

$$1.5EI\Delta_{DC} = 72R - 3240$$

$$\therefore \Delta_{DC} = \frac{48R - 2160}{EI}$$

Note that to have neglected the different EI value for member CD would change the result significantly.

Solve for R

By compatibility of displacement we have $\Delta_{DC} = 6\theta_C$ and so:

$$48R - 2160 = 6(3360 - 48R)$$

$$336R = 22320$$

$$R = 66.43 \text{ kN}$$

With R now known we can calculate the horizontal deflection at D .

Part (b) - Horizontal Deflection at D

From the deflected shape diagram of the final frame and by neglecting axial deformation of member CD , we see that the horizontal displacement at D must be the same as that at C . Note that it is easier at this stage to work with the simpler shape of the separate primary and reactant BMDs. Using Mohr II we can find δ_{Cx} as shown:

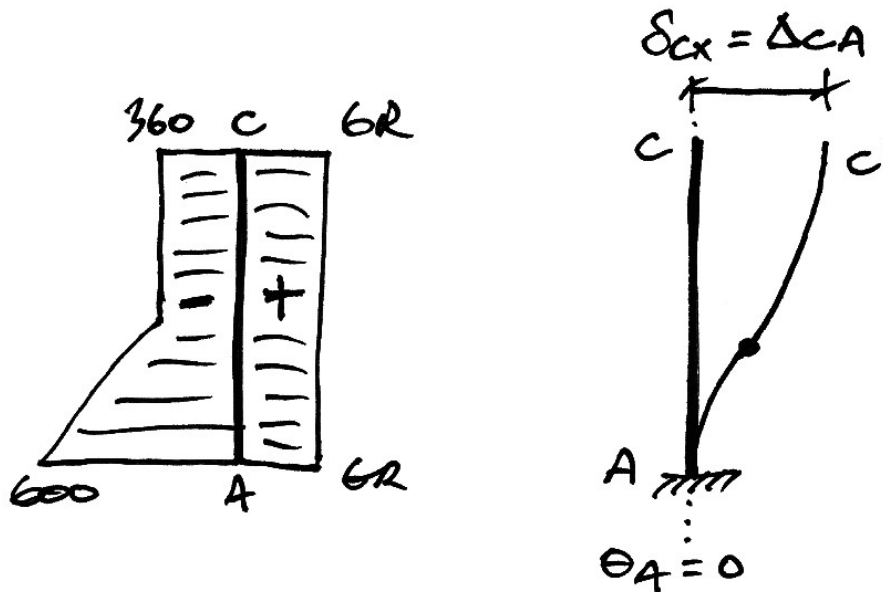

$$EI\Delta_{BA} = [(6R \cdot 8)(4)] - \left[(360 \cdot 8)(4) + \left(\frac{1}{2} \cdot 4 \cdot 240 \right) \left(4 + \frac{2}{3} \cdot 4 \right) \right]$$

$$= 192R - 14720$$

Now substituting $R = 66.4 \text{ kN}$ and $\delta_{Dx} = \delta_{Cx} = \Delta_{BA}$:

$$\delta_{Dx} = \frac{-1971.2}{EI} = 49.3 \text{ mm} \rightarrow$$

Note that the negative sign indicates that the bending on the outside of the frame dominates, pushing the frame to the right as we expected.

Part (a) – Reactions and Bending Moment Diagram

Reactions

Taking the whole frame, and showing the calculated value for R , we have:

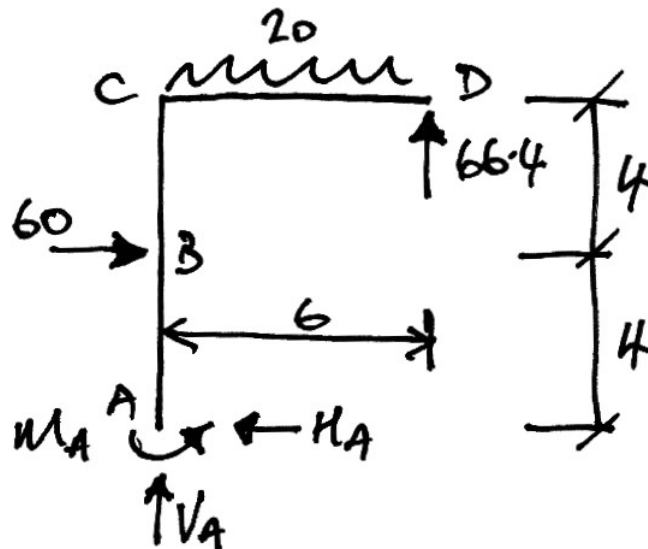

$$\sum F_y = 0 \quad \therefore (20 \cdot 6) - 66.4 - V_A = 0 \quad \therefore V_A = 53.6 \text{ kN } \uparrow$$

$$\sum F_x = 0 \quad \therefore H_A - 60 = 0 \quad \therefore H_A = 60 \text{ kN } \leftarrow$$

$$\sum M \text{ about } A = 0 \quad \therefore M_A + 66.4 \cdot 6 - 20 \cdot \frac{6^2}{2} - 60 \cdot 4 = 0 \quad \therefore M_A = +201.6 \text{ kNm}$$

Note that it is easier to use the superposition of the primary and reactant BMDs to find the moment at A :

$$M_A = 6(66.4) - 600 = -201.6 \text{ kNm}$$

The negative sign indicates the moment on the outside of the frame dominates and so tension is on the left.

Bending Moment Diagram

We find the moments at salient points:

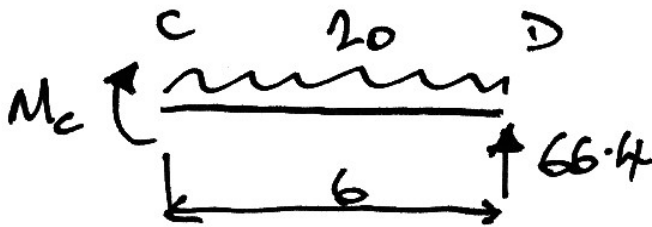

$$\sum M \text{ about } C = 0$$

$$\therefore M_C + 20 \cdot \frac{6^2}{2} - 66.4 \cdot 6 = 0$$

$$\therefore M_C = +38.4 \text{ kNm}$$

And so tension is on the bottom at C.

The moment at B is most easily found from superposition of the BMDs as before:

$$M_B = 6(66.4) - 360 = 38.4 \text{ kNm}$$

And so tension is on the inside of the frame at B. Lastly we must find the value of maximum moment in span CD. The position of zero shear is found as:

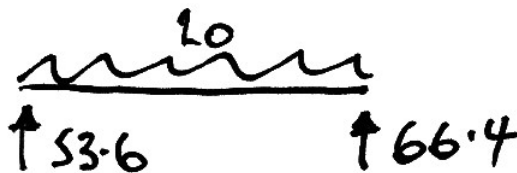

$$x = \frac{53.6}{20} = 2.68 \text{ m}$$



And so the distance from D is:

$$6 - 2.68 = 3.32 \text{ m}$$

The maximum moment is thus found from a free body diagram as follows:

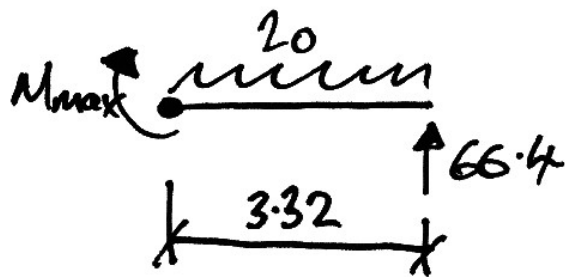

$$\sum M \text{ about } X = 0$$

$$\therefore M_{\max} + 20 \cdot \frac{3.32^2}{2} - 66.4 \cdot 3.32 = 0$$

$$\therefore M_C = +110.2 \text{ kNm}$$

And so tension is on the bottom as expected.

Summary of Solution

In summary the final solution for this frame is:

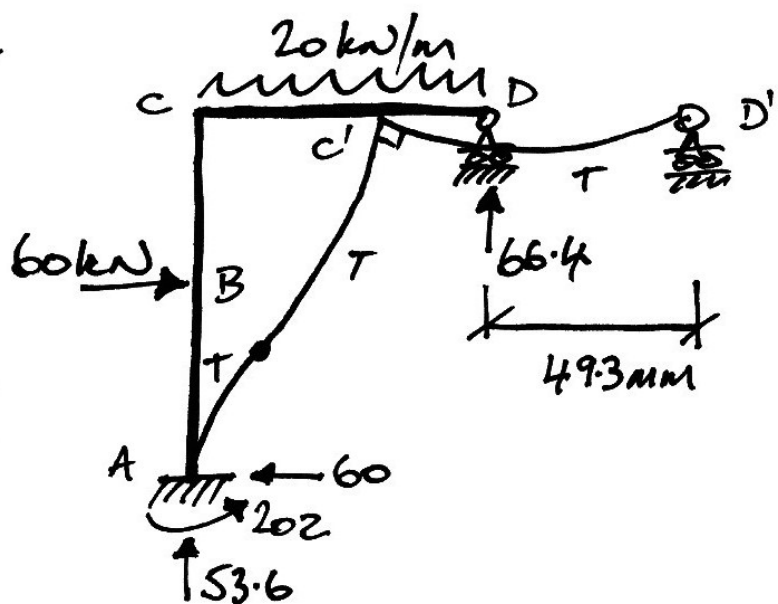
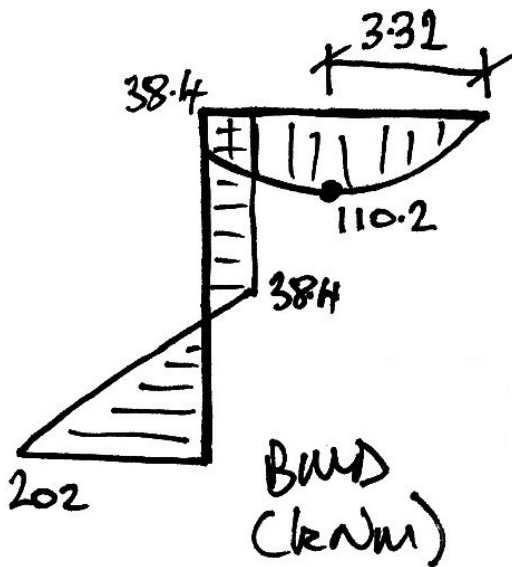

4.6 Problems

1. For the following prismatic beam, find the bending moment diagram and the rotation at E in terms of EI .

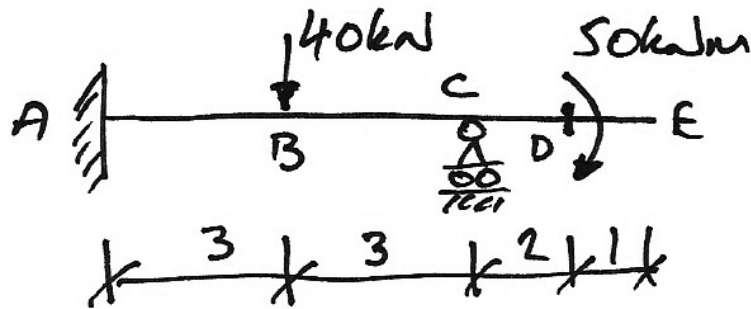

2. For the following prismatic beam, find the bending moment diagram and the rotation at C in terms of EI . (Autumn 2007)

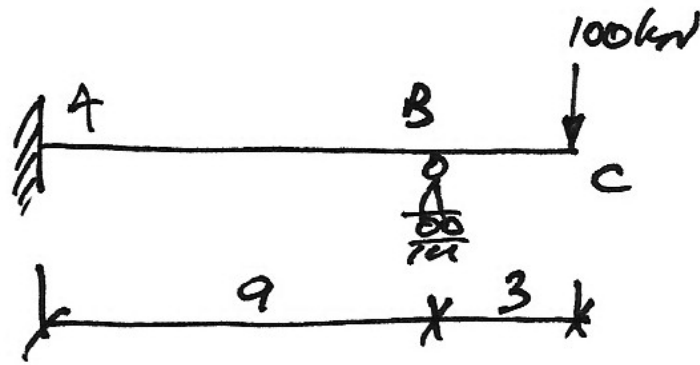

3. For the following prismatic frame, find the bending moment and shear force diagrams and the horizontal deflection at E in terms of EI .

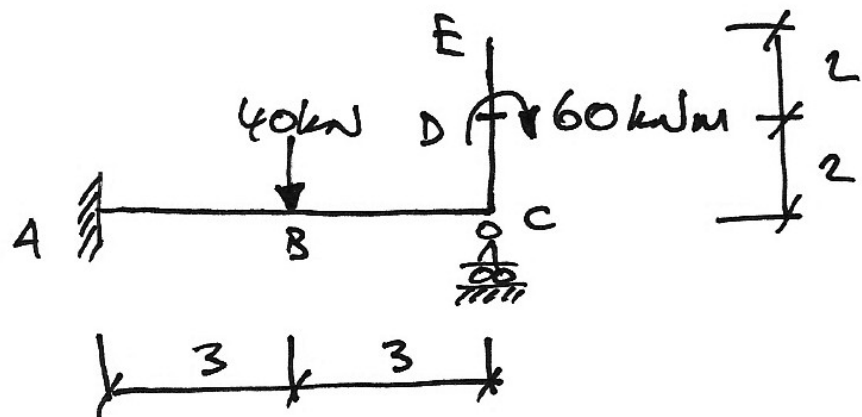

4. For the following prismatic frame, find the bending moment diagram and the horizontal deflection at D in terms of EI . (Summer 2006)

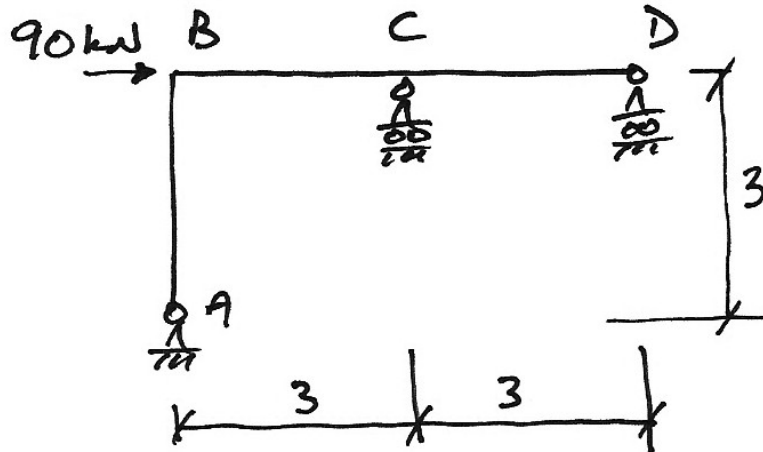

5. For the following prismatic frame, find the bending moment diagram and the horizontal deflection at C in terms of EI . (Summer 2007)

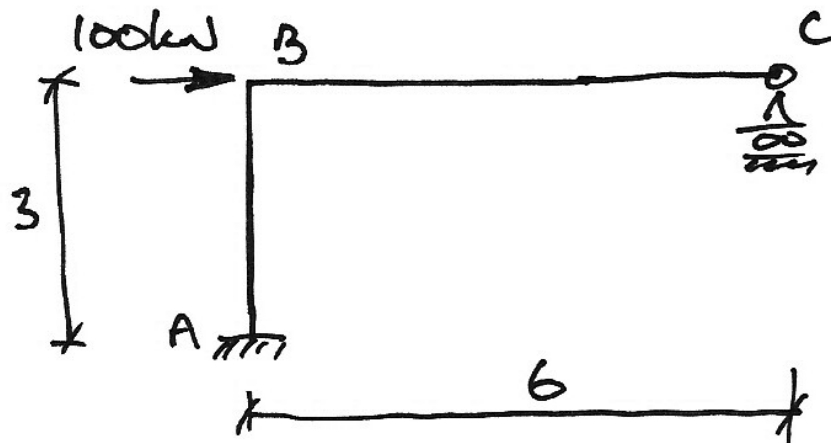

6. Draw the bending moment diagram and find the maximum deflection for the following beam. Take $EI = 20 \times 10^3 \text{ kNm}^2$. (Semester 1 2007/8)

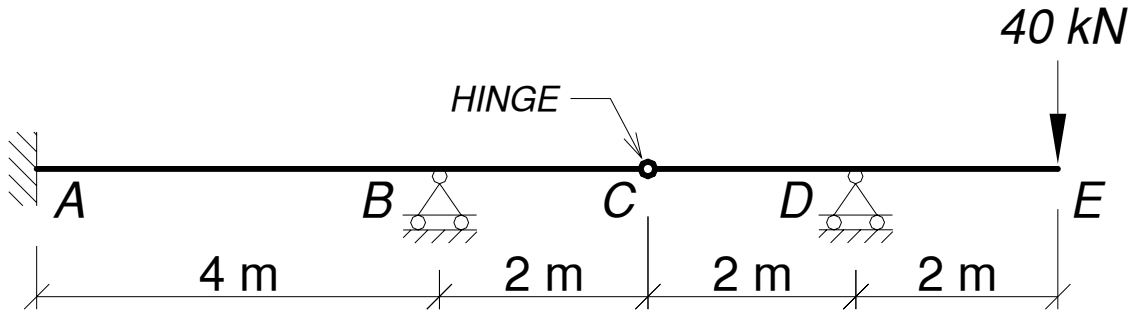

7. Draw the bending moment diagram and determine the horizontal deflection at D for the following frame. Take $EI = 4 \times 10^3 \text{ kNm}^2$. (Summer 1998)

