

**Structural Analysis III**  
***Moment Distribution***

**2009/10**

**Dr. Colin Caprani**

## Contents

<b>1. Introduction .....</b>	<b>4</b>
1.1 Overview.....	4
1.2 The Basic Idea .....	5
<b>2. Development.....</b>	<b>10</b>
2.1 Carry-Over Factor.....	10
2.2 Fixed-End Moments .....	13
2.3 Rotational Stiffness.....	16
2.4 Distributing the Balancing Moment .....	19
2.5 Moment Distribution Iterations .....	23
<b>3. Beam Examples.....</b>	<b>24</b>
3.1 Example 1: Introductory Example.....	24
3.2 Example 2: Iterative Example .....	28
3.3 Example 3: Pinned End Example .....	41
3.4 Example 4: Cantilever Example .....	47
3.5 Example 5: Support Settlement .....	54
3.6 Problems .....	59
<b>4. Non-Sway Frames.....</b>	<b>62</b>
4.1 Introduction.....	62
4.2 Example 6: Simple Frame .....	66
4.3 Example 7: Frame with Pinned Support.....	73
4.4 Example 8: Frame with Cantilever.....	80
4.5 Problems .....	84
<b>5. Sway Frames .....</b>	<b>88</b>
5.1 Basis of Solution.....	88
5.2 Example 9: Illustrative Sway Frame .....	93
5.3 Example 10: Simple Sway Frame .....	100
5.4 Arbitrary Sway of Rectangular Frames .....	110

5.5	Example 11: Rectangular Sway Frame .....	115
5.6	Problems I.....	124
5.7	Arbitrary Sway of Oblique Frames Using Geometry.....	128
5.8	Example 12: Oblique Sway Frame I .....	135
5.9	Arbitrary Sway of Oblique Frames Using the ICR .....	146
5.10	Example 13: Oblique Sway Frame II.....	155
5.11	Problems II.....	163
<b>6.</b>	<b>Appendix .....</b>	<b>165</b>
6.1	Past Exam Papers.....	165
6.2	Fixed End Moments.....	169

# 1. Introduction

## 1.1 Overview

### Background

Moment Distribution is an iterative method of solving an indeterminate structure. It was developed by Prof. Hardy Cross in the US in the 1920s in response to the highly indeterminate structures being built at the time. The method is a 'relaxation method' in that the results converge to the true solution through successive approximations. Moment distribution is very easily remembered and extremely useful for checking computer output of highly indeterminate structures.

A good background on moment distribution can be got from:

<http://www.emis.de/journals/NNJ/Eaton.html>



**Hardy Cross (1885-1959)**



## 1.2 The Basic Idea

### Sample Beam

We first consider a two-span beam with only one possible rotation. This beam is subject to different loading on its two spans. The unbalanced loading causes a rotation at  $B$ ,  $\theta_B$ , to occur, as shown:

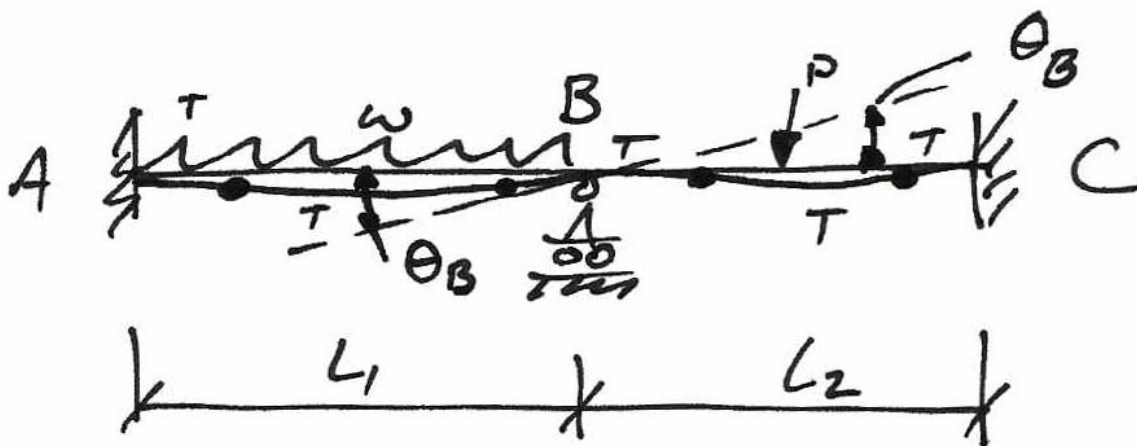

To analyse this structure, we use the regular tools of superposition and compatibility of displacement. We will make the structure more indeterminate first, and then examine what happens to the extra unknown moment introduced as a result.

### Superposition

The following diagrams show the basic superposition used:

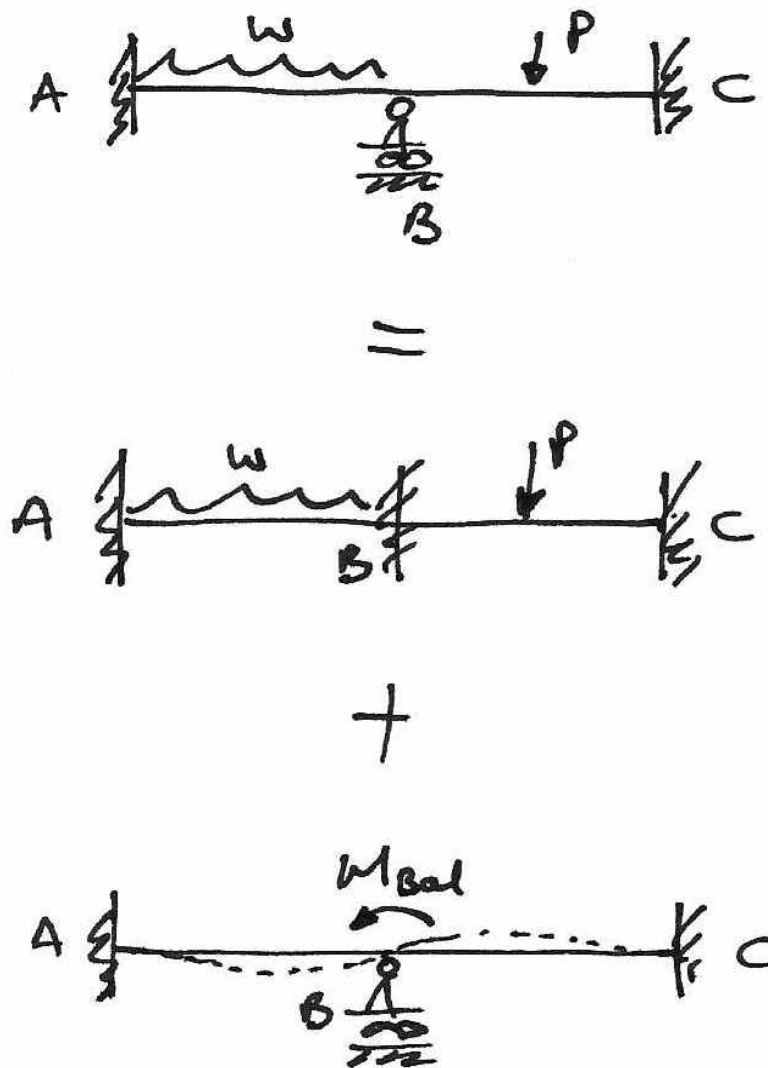

The newly introduced fixed support does not allow any rotation of joint  $B$ . Therefore a net moment results at this new support – a moment that ‘balances’ the loading,  $M_{Bal}$ . Returning to the original structure, we account for the effect of the introduced restraint by applying  $M_{Bal}$  in the opposite direction. In this way, when the superposition in the diagram is carried out, we are left with our original structure.

### The Balancing Moment

The moment  $M_{Bal}$  'goes into' each of the spans  $AB$  and  $BC$ . The amount of  $M_{Bal}$  in each span is  $M_{BA}$  and  $M_{BC}$  respectively. That is,  $M_{Bal}$  splits, or distributes, itself into  $M_{BA}$  and  $M_{BC}$ . We next analyse each of the spans separately for the effects of  $M_{BA}$  and  $M_{BC}$ . This is summarized in the next diagram:

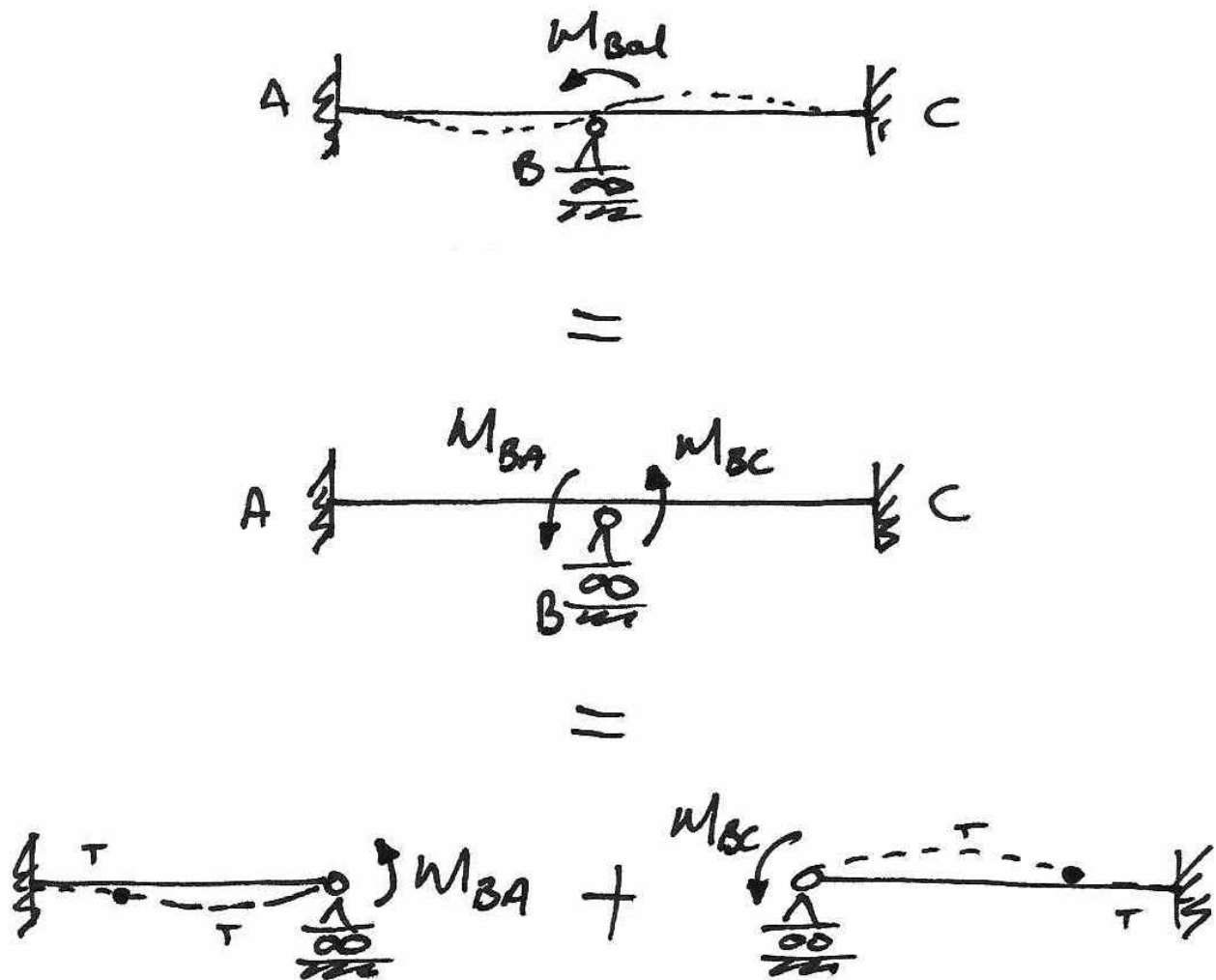

### The Fixed-End-Moments

The balancing moment arises from the applied loads to each span. By preventing joint  $B$  from rotating (having placed a fixed support there), a moment will result in the support. We can find this moment by examining the fixed end moments (FEMs) for each fixed-fixed span and its loading:

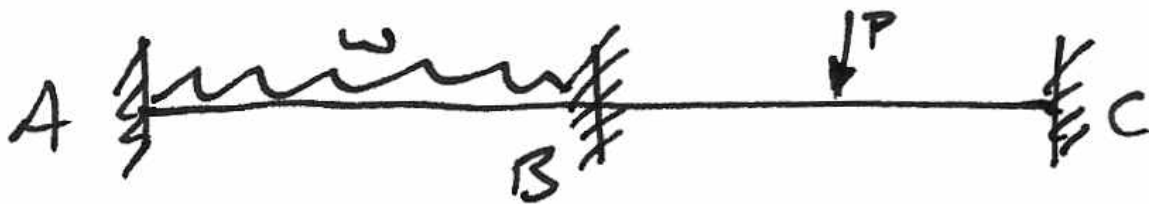

Both of these new “locked” beams have fixed end moment (FEM) reactions as:

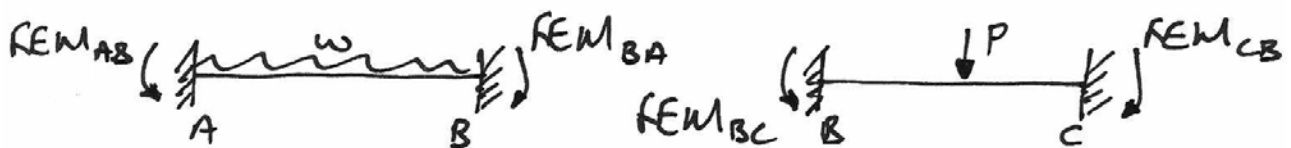

And for the particular type of loading we can work out these FEMs from tables of FEMs:

$$FEM_{AB} = \frac{wl_1^2}{12} \quad \left( \text{Diagram of span AB with load } w \right) \quad FEM_{BA} = -\frac{wl_1^2}{12}$$

$$FEM_{BC} = \frac{Pl}{8} \quad \left( \text{Diagram of span BC with load } P \right) \quad FEM_{CB} = -\frac{Pl}{8}$$

Note the sign convention:



Anti-clockwise is positive



Clockwise is negative

From the locked beams  $AB$  and  $BC$ , we see that at  $B$  (in general) the moments do not balance (if they did the rotation,  $\theta_B$ , would not occur). That is:

$$-\frac{wL_1^2}{12} + \frac{PL_2}{8} + M_{Bal} = 0$$

And so we have:

$$M_{Bal} = \frac{PL_2}{8} - \frac{wL_1^2}{12}$$

In which the sign (i.e. the direction) will depend on the relative values of the two FEMs caused by the loads.

The balancing moment is the moment required at  $B$  in the original beam to stop  $B$  rotating. Going back to the basic superposition, we find the difference in the two FEMs at the joint and apply it as the balancing moment in the opposite direction.

Next we need to find out how the balancing moment splits itself into  $M_{BA}$  and  $M_{BC}$ .

## 2. Development

### 2.1 Carry-Over Factor

The carry-over factor relates the moment applied at one end of a beam to the resulting moment at the far end. We find this for the beams of interest.

#### Fixed-Pinned

For a fixed-pinned beam, subject to a moment at the pinned end, we have:

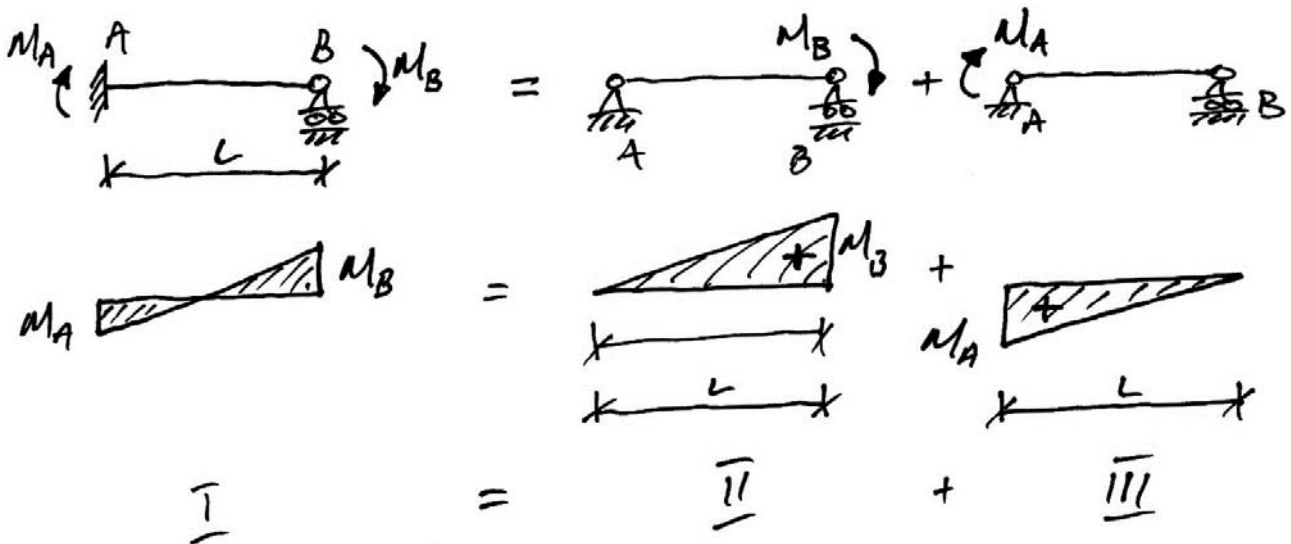

To solve this structure, we note first that the deflection at  $B$  in structure I is zero, i.e.  $\delta_B = 0$  and so since the tangent at  $A$  is horizontal, the vertical intercept is also zero, i.e.  $\Delta_{BA} = 0$ . Using superposition, we can calculate  $[\Delta_{BA}]_I$  as:

$$[\Delta_{BA}]_I = [\Delta_{BA}]_{II} + [\Delta_{BA}]_{III}$$

where the subscript relates to the structures above. Thus we have, by Mohr's Second Theorem:

$$EI\Delta_{BA} = \left[ \frac{1}{2} M_B L \right] \left[ \frac{L}{3} \right] - \left[ \frac{1}{2} M_A L \right] \left[ \frac{2L}{3} \right] = 0$$

And so,

$$\begin{aligned} \frac{M_B L^2}{6} &= \frac{M_A L^2}{3} \\ 3M_B &= 6M_A \\ M_A &= +\frac{1}{2} \cdot M_B \end{aligned}$$

The factor of  $+\frac{1}{2}$  that relates  $M_A$  to  $M_B$  is known as the carry-over factor (COF).

The positive sign indicates that  $M_A$  acts in the same direction as  $M_B$ :

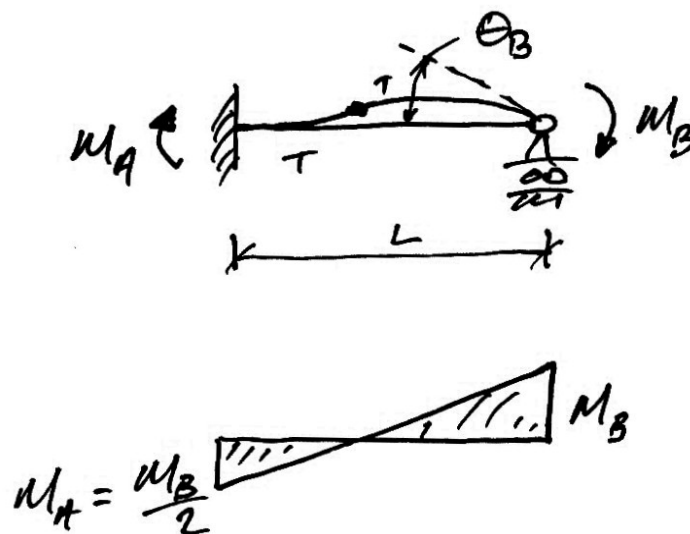

We generalize this result slightly and say that for any remote end that has the ability to restrain rotation:

$$COF = +\frac{1}{2} \text{ for an end that has rotational restraint}$$

### Pinned-Pinned

As there can be no moment at a pinned end there is no carry over to the pinned end:

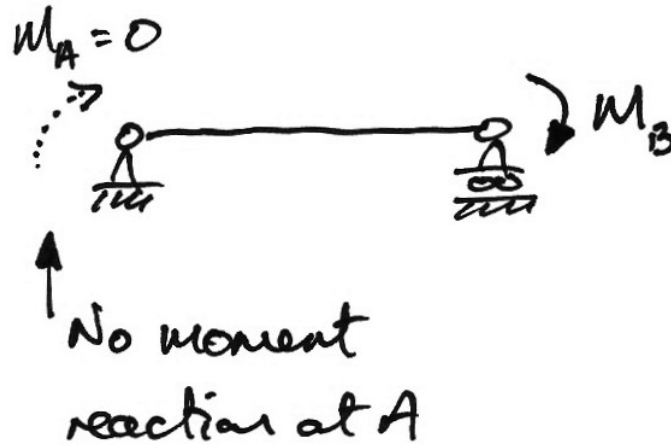

We generalize this from a pinned-end to any end that does not have rotational restraint:

There is no carry-over to an end not rotationally restrained.



## 2.2 Fixed-End Moments

### Direct Loading

When the joints are initially locked, all spans are fixed-fixed and the moment reactions (FEMs) are required. These are got from standard solutions:

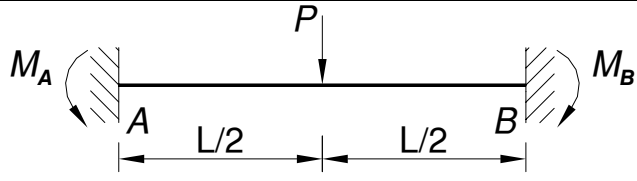
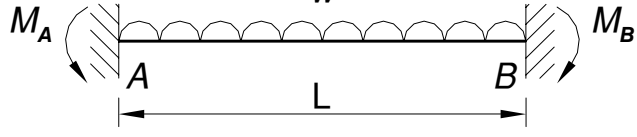
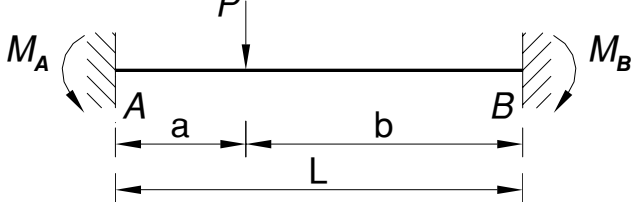
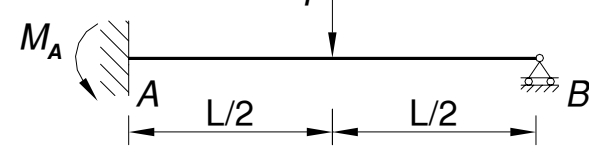
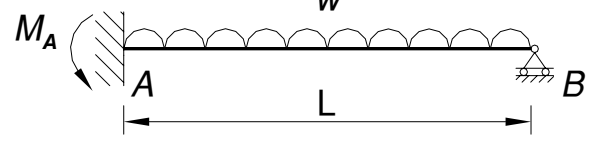
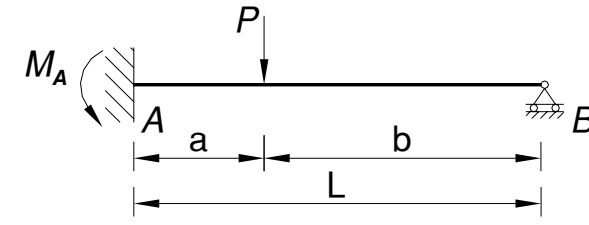
$M_A$	Configuration	$M_B$
$+\frac{PL}{8}$		$-\frac{PL}{8}$
$+\frac{wL^2}{12}$		$-\frac{wL^2}{12}$
$+\frac{Pab^2}{L^2}$		$-\frac{Pa^2b}{L^2}$
$+\frac{3PL}{16}$		-
$+\frac{wL^2}{8}$		-
$+\frac{Pab(2L-a)}{2L^2}$		-

### Support Settlement

The movement of supports is an important design consideration, especially in bridges, as the movements can impose significant additional moments in the structure. To allow for this we consider two cases:

#### Fixed-Fixed Beam

Consider the following movement which imposes moments on the beam:

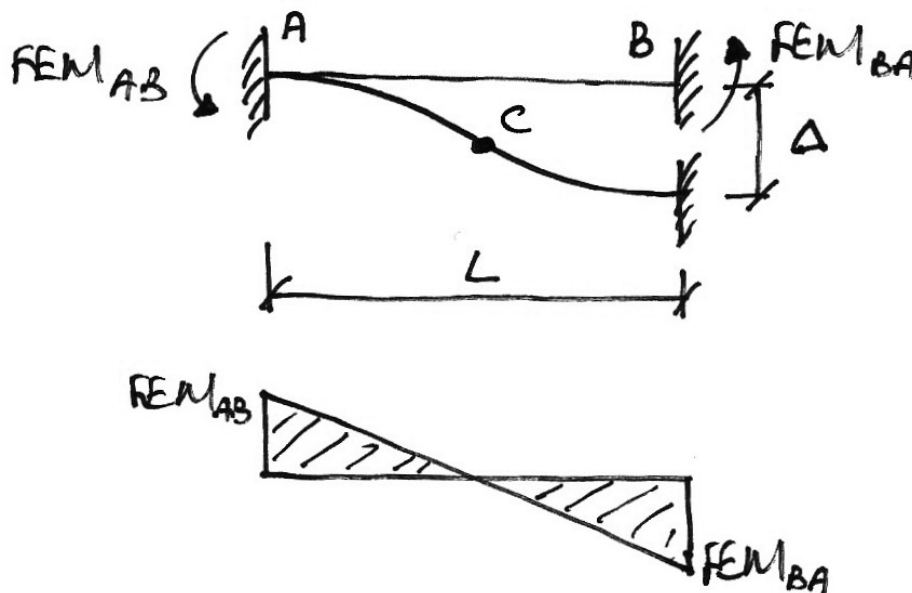

At C the deflection is  $\Delta/2$ ; hence we must have  $FEM_{AB} = FEM_{BA}$ . Using Mohr's Second Theorem, the vertical intercept from C to A is:

$$\begin{aligned} \frac{\Delta}{2} &\equiv \Delta_{CA} \\ &= \left[ \frac{1}{2} \cdot \frac{L}{2} \cdot \frac{FEM_{AB}}{EI} \right] \left[ \frac{2}{3} \cdot \frac{L}{2} \right] = \frac{FEM_{AB} L^2}{12EI} \\ \therefore FEM_{AB} &= \frac{6EI\Delta}{L^2} = FEM_{BA} \end{aligned}$$

**Fixed-Pinned Beam**

Again, the support settlement imposes moments as:

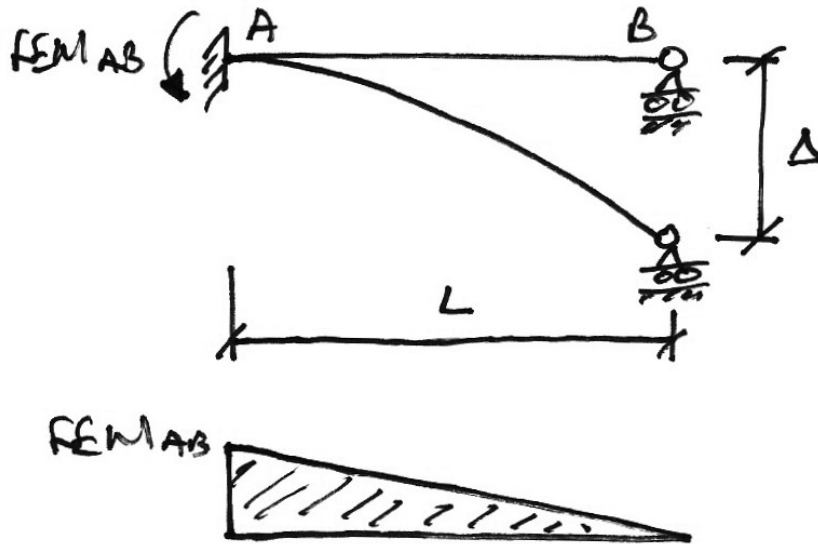

Following the same procedure:

$$\Delta \equiv \Delta_{BA} = \left[ \frac{1}{2} \cdot L \cdot \frac{FEM_{AB}}{EI} \right] \left[ \frac{2}{3} \cdot L \right] = \frac{FEM_{AB} L^2}{3EI}$$

$$\therefore FEM_{AB} = \frac{3EI\Delta}{L^2}$$

In summary then we have:

$M_A$	Configuration	$M_B$
$+\frac{6EI\Delta}{L^2}$		$+\frac{6EI\Delta}{L^2}$
$+\frac{3EI\Delta}{L^2}$		-

## 2.3 Rotational Stiffness

### Concept

Recall that  $F = K\delta$  where  $F$  is a force,  $K$  is the stiffness of the structure and  $\delta$  is the resulting deflection. For example, for an axially loaded rod or bar:

$$F = \frac{EA}{L} \cdot \delta$$

And so  $K = EA/L$ . Similarly, when a moment is applied to the end of a beam, a rotation results, and so we also have:

$$M = K_{\theta} \cdot \theta$$

Note that  $K_{\theta}$  can be thought of as the moment required to cause a rotation of 1 radian. We next find the rotational stiffnesses for the relevant types of beams.

### Fixed-Pinned Beam

To find the rotational stiffness for this type of beam we need to find the rotation,  $\theta_B$ , for a given moment applied at the end,  $M_B$ :

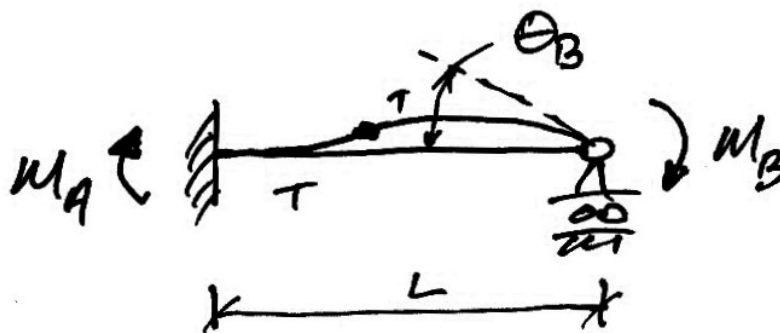

We break the bending moment diagram up as follows, using our knowledge of the carry-over factor:

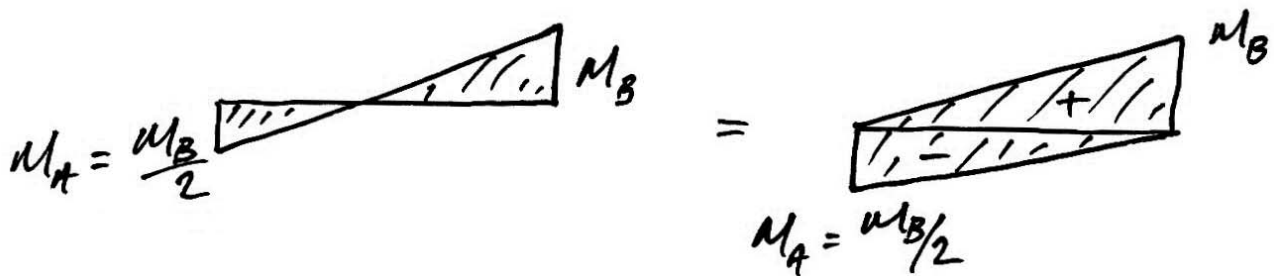

The change in rotation from  $A$  to  $B$  is found using Mohr's First Theorem and the fact that the rotation at the fixed support,  $\theta_A$ , is zero:

$$d\theta_{AB} = \theta_B - \theta_A = \theta_B$$

Thus we have:

$$\begin{aligned} EI\theta_B &= \frac{1}{2}M_B L - \frac{1}{2}M_A L \\ &= \frac{M_B L}{2} - \frac{M_B L}{4} \\ &= \frac{M_B L}{4} \\ \theta_B &= \frac{L}{4EI}M_B \end{aligned}$$

And so,

$$M_B = \frac{4EI}{L}\theta_B$$

And the rotational stiffness for this type of beam is:

$$K_\theta = \frac{4EI}{L}$$

**Pinned-Pinned Beam**

For this beam we use an alternative method to relate moment and rotation:

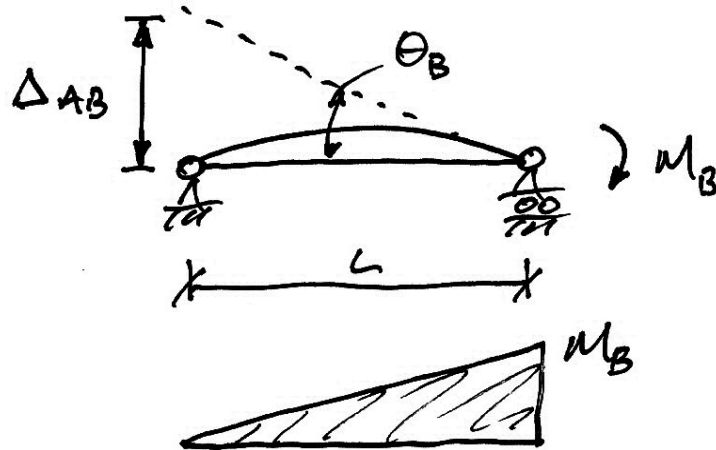

By Mohr's Second Theorem, and the fact that  $\Delta_{AB} = \theta_B L$ , we have:

$$EI\Delta_{AB} = \left[ \frac{1}{2} M_B L \right] \left[ \frac{2}{3} L \right]$$

$$EI\theta_B L = \frac{M_B L^2}{3}$$

$$\theta_B = \frac{L}{3EI} M_B$$

And so:

$$M_B = \frac{3EI}{L} \cdot \theta_B$$

Thus the rotational stiffness for a pinned-pinned beam is:

$$K_\theta = \frac{3EI}{L}$$

## 2.4 Distributing the Balancing Moment

### Distribution Factor

Returning to the original superposition in which the balancing moment is used, we now find how the balancing moment is split. We are considering a general case in which the lengths and stiffnesses may be different in adjacent spans:

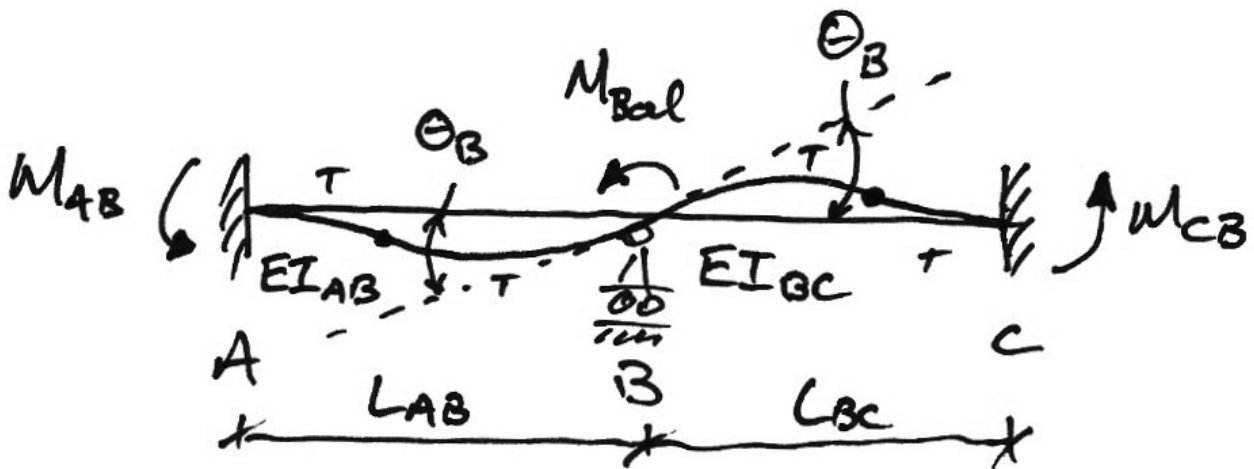

So from this diagram we can see that the rotation at joint B,  $\theta_B$ , is the same for both spans. We also note that the balancing moment is split up;  $M_{BA}$  of it causes span AB to rotate  $\theta_B$  whilst the remainder,  $M_{BC}$ , causes span BC to rotate  $\theta_B$  also:

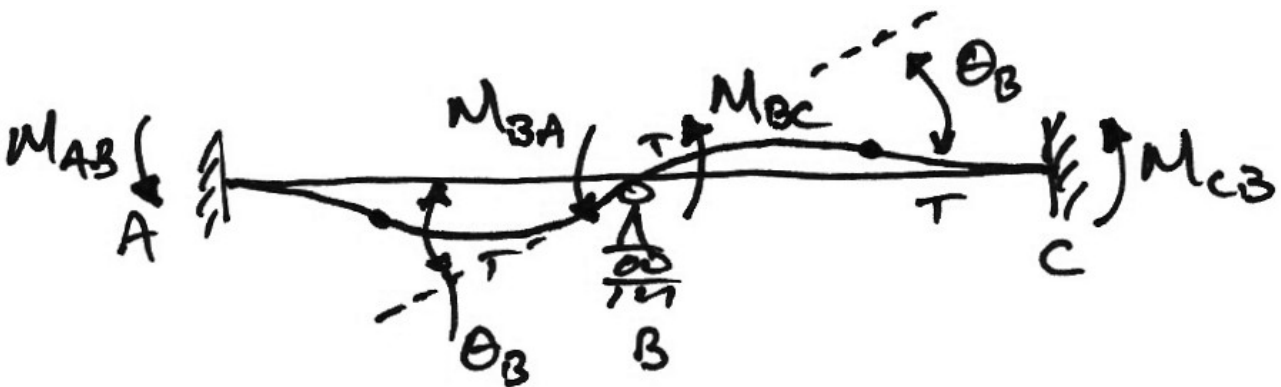

If we now split the beam at joint  $B$  we must still have  $\theta_B$  rotation at joint  $B$  for compatibility of displacement in the original beam:

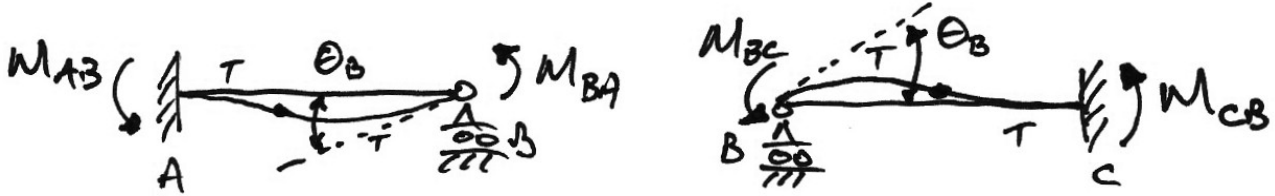

Thus:

$$[\theta_B]_{AB} = \frac{M_{BA}}{K_{AB}} \quad \text{and} \quad [\theta_B]_{BC} = \frac{M_{BC}}{K_{BC}}$$

$$M_{BA} = K_{AB} \cdot \theta_B \quad \text{and} \quad M_{BC} = K_{BC} \cdot \theta_B$$

But since from the original superposition,  $M_{Bal} = M_{BA} + M_{BC}$ , we have:

$$\begin{aligned} M_{Bal} &= M_{BA} + M_{BC} \\ &= K_{BA} \theta_B + K_{BC} \theta_B \\ &= (K_{BA} + K_{BC}) \theta_B \end{aligned}$$

And so:

$$\theta_B = \frac{M_{Bal}}{(K_{BA} + K_{BC})}$$

Thus, substituting this expression for  $\theta_B$  back into the two equations:

$$M_{BA} = K_{AB} \theta_B = \left[ \frac{K_{AB}}{K_{AB} + K_{BC}} \right] \cdot M_{Bal}$$



$$M_{BC} = K_{BC} \theta_B = \left[ \frac{K_{BC}}{K_{AB} + K_{BC}} \right] \cdot M_{Bal}$$

The terms in brackets are called the distribution factors (DFs) for a member. Examine these expressions closely:

- The DFs dictate the amount of the balancing moment to be distributed to each span (hence the name);
- The DFs are properties of the spans solely,  $K \propto EI/L$ ;
- The DF for a span is its relative stiffness at the joint.

This derivation works for any number of members meeting at a joint. So, in general, the distribution factor for a member at a joint is the member stiffness divided by the sum of the stiffnesses of the *members meeting at that joint*:

$$DF_{BA} = \frac{K_{BA}}{\sum K}$$

A useful check on your calculations thus far is that since a distribution factor for each member at a joint is calculated, the sum of the DFs for the joint must add to unity:

$$\sum_{\text{Joint X}} \text{DFs} = 1$$

If they don't a mistake has been made since not all of the balancing moment will be distributed and moments can't just vanish!

### Relative Stiffness

Lastly, notice that the distribution factor only requires relative stiffnesses (i.e. the stiffnesses are divided). Therefore, in moment distribution, we conventionally take the stiffnesses as:

1. member with continuity at both ends:

$$k = \frac{EI}{L}$$

2. member with no continuity at one end:

$$k' = \frac{3}{4}k = \frac{3}{4} \frac{EI}{L}$$

In which the  $k'$  means a modified stiffness to account for the pinned end (for example).

Note that the above follows simply from the fact that the absolute stiffness is  $4EI/L$  for a beam with continuity at both ends and the absolute stiffness for a beam without such continuity is  $3EI/L$ . This is obviously  $3/4$  of the continuity absolute stiffness.

## 2.5 *Moment Distribution Iterations*

In the preceding development we only analysed the effects of a balancing moment on one joint at a time. The structures we wish to analyse may have many joints. Thus: if we have many joints and yet can only analyse one at a time, what do we do?

To solve this, we introduce the idea of ‘locking’ a joint, which is just applying a fixed support to it to restrain rotation. With this in mind, the procedure is:

1. Lock all joints and determine the fixed-end moments that result;
2. Release the lock on a joint and apply the balancing moment to that joint;
3. Distribute the balancing moment and carry over moments to the (still-locked) adjacent joints;
4. Re-lock the joint;
5. Considering the next joint, repeat steps 2 to 4;
6. Repeat until the balancing and carry over moments are only a few percent of the original moments.

The reason this is an iterative procedure is (as we will see) that carrying over to a previously balanced joint unbalances it again. This can go on ad infinitum and so we stop when the moments being balanced are sufficiently small (about 1 or 2% of the start moments). Also note that some simple structures do not require iterations. Thus we have the following rule:

*For structures requiring distribution iterations, always finish on a distribution, never on a carry over*

This leaves all joints balanced (i.e. no unbalancing carry-over moment) at the end.

### 3. Beam Examples

#### 3.1 Example 1: Introductory Example

This example is not the usual form of moment distribution but illustrates the process of solution.

#### Problem

Consider the following prismatic beam:

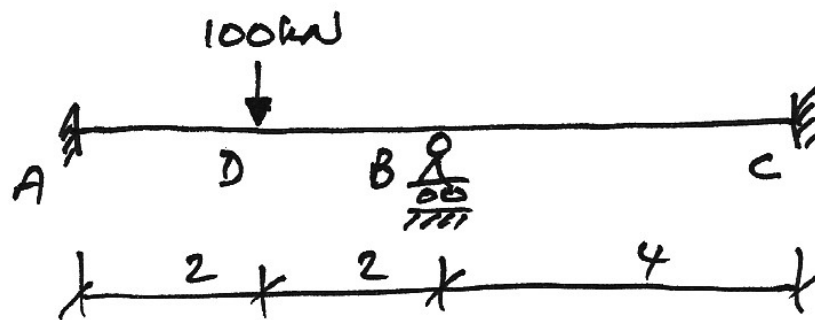

#### Solution

To solve this, we will initially make it 'worse'. We clamp the support at B to prevent rotation. In this case, span AB is a fixed-fixed beam which has moment reactions:

$$FEM_{AB} = +\frac{PL}{8} = +50 \text{ kNm} \quad FEM_{BA} = -\frac{PL}{8} = -50 \text{ kNm}$$

Notice that we take anticlockwise moments to be negative.

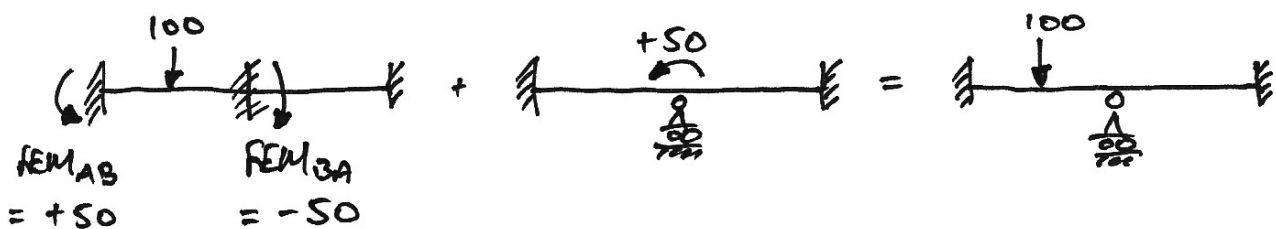

The effect of clamping joint  $B$  has introduced a moment of  $-50$  kNm at joint  $B$ . To *balance* this moment, we will apply a moment of  $+50$  kNm at joint  $B$ . Thus we are using the principle of superposition to get back our original structure.

We know the bending moment diagram for the fixed-fixed beam readily. From our previous discussion we find the bending moments for the balancing  $+50$  kNm at joint  $B$  as follows:

Since  $EI$  is constant, take it to be 1; then the stiffnesses are:

$$k_{BA} = \left( \frac{EI}{L} \right)_{AB} = \frac{1}{4} = 0.25 \quad k_{BC} = \left( \frac{EI}{L} \right)_{BC} = \frac{1}{4} = 0.25$$

At joint  $B$  we have:

$$\sum k = \frac{1}{4} + \frac{1}{4} = 0.5$$

Thus the distribution factors are:

$$DF_{BA} = \frac{k_{BA}}{\sum k} = \frac{0.25}{0.5} = 0.5 \quad DF_{BC} = \frac{k_{BC}}{\sum k} = \frac{0.25}{0.5} = 0.5$$

Thus the ‘amount’ of the  $+50$  kNm applied at joint  $B$  give to each span is:

$$M_{BA} = DF_{BA} \cdot M_{Bal} = 0.5 \times +50 = +25 \text{ kNm}$$
$$M_{BC} = DF_{BC} \cdot M_{Bal} = 0.5 \times +50 = +25 \text{ kNm}$$

We also know that there will be carry-over moments to the far ends of both spans:

$$M_{AB} = COF \cdot M_{BA} = \frac{1}{2} \cdot +25 = +12.5 \text{ kNm}$$

$$M_{CB} = COF \cdot M_{BC} = \frac{1}{2} \cdot +25 = +12.5 \text{ kNm}$$

All of this can be easily seen in the bending moment diagram for the applied moment and the final result follows from superposition:

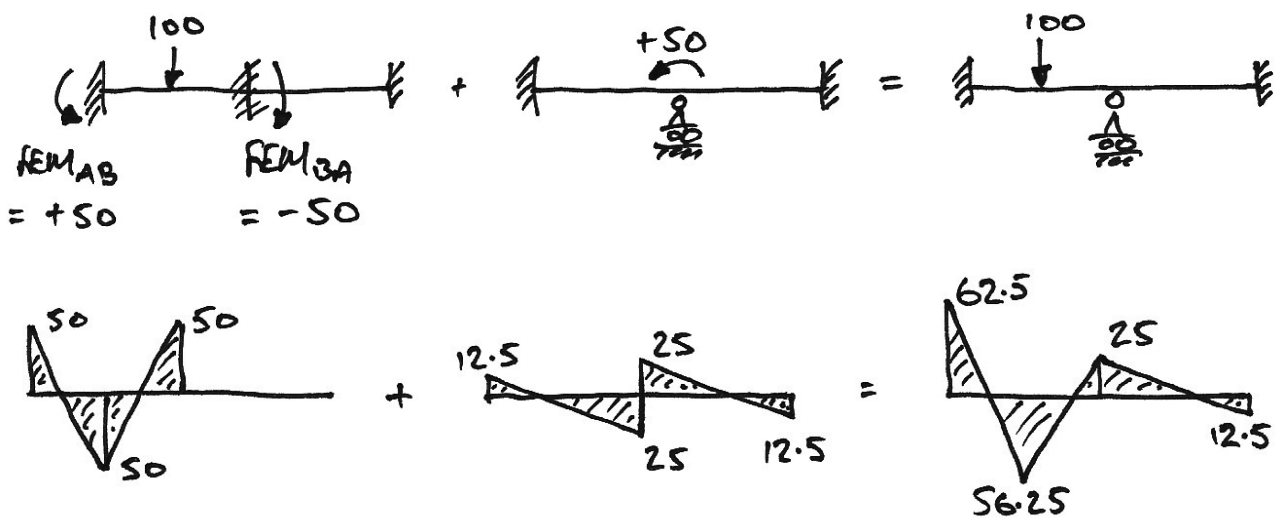

These calculations are usually expressed in a much quicker tabular form as:

Joint	A	B		C	
	Member	AB	BA	BC	
DF	1	0.5	0.5	1	
FEM	+50	-50			
Dist.		+25	+25		Note 1
C.O.	+12.5			+12.5	Note 2
Final	+62.5	-25	+25	+12.5	Note 3

**Note 1:**

The -50 kNm is to be balanced by +50 kNm which is distributed as +25 kNm and +25 kNm.

**Note 2:**

Both of the +25 kNm moments are distributed to the far ends of the members using the carry over factor of  $+\frac{1}{2}$ .

**Note 3:**

The moments for each joint are found by summing the values vertically.

And with more detail, the final BMD is:

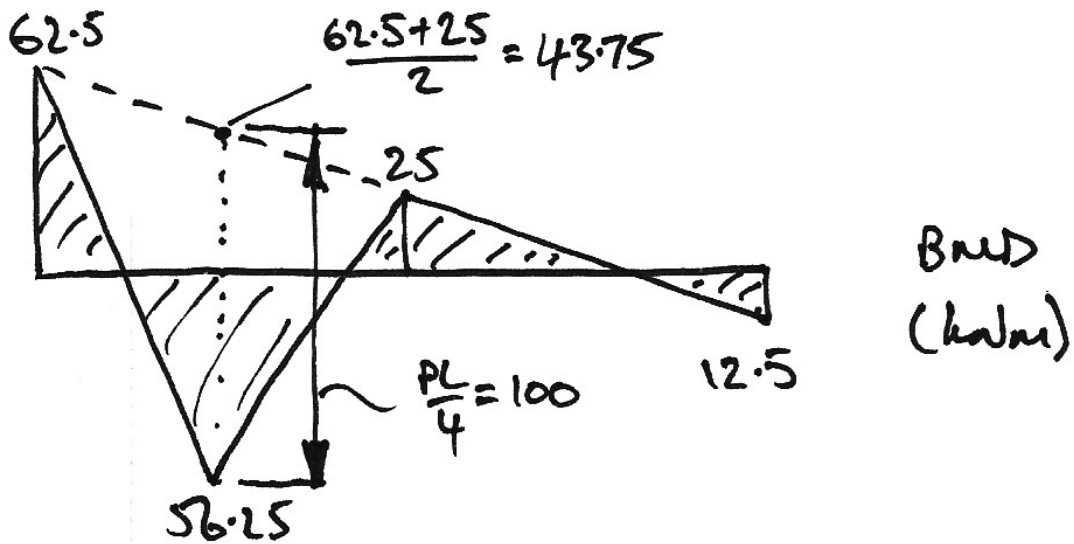

Once the bending moment diagram has been found, the reactions and shears etc can be found by statics.

### 3.2 Example 2: Iterative Example

For the following beam, we will solve it using the ordinary moment distribution method and then explain each step on the basis of locking and unlocking joints mentioned previously.

All members have equal  $EI$ .

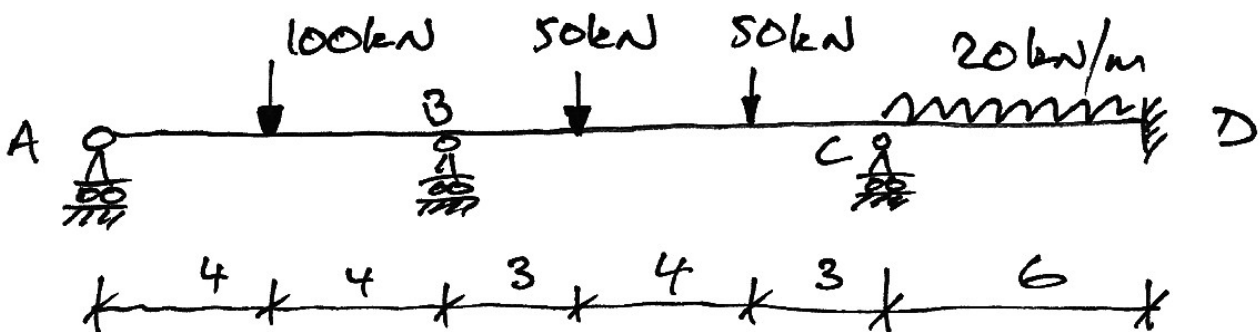

#### Ordinary Moment Distribution Analysis

1. The stiffness of each span is:

- $AB: k_{BA} = \frac{3}{4} \left( \frac{EI}{L} \right)_{AB} = \frac{3}{4} \left( \frac{1}{8} \right) = \frac{3}{32}$

- $BC: k_{BC} = \frac{1}{10}$

- $CD: k_{CD} = \frac{1}{6}$

2. The distribution factors at each joint are:

- Joint B:

$$\sum k = \frac{3}{32} + \frac{1}{10} = 0.1937$$



$$\left. \begin{aligned} DF_{BA} &= \frac{k_{BA}}{\sum k} = \frac{3/32}{0.1937} = 0.48 \\ DF_{BC} &= \frac{k_{BC}}{\sum k} = \frac{0.1}{0.1937} = 0.52 \end{aligned} \right\} \sum DF_s = 1$$

- Joint C:

$$\sum k = \frac{1}{10} + \frac{1}{6} = 0.2666$$

$$\left. \begin{aligned} DF_{CB} &= \frac{k_{CB}}{\sum k} = \frac{0.1}{0.2666} = 0.375 \\ DF_{CD} &= \frac{k_{CD}}{\sum k} = \frac{0.1666}{0.2666} = 0.625 \end{aligned} \right\} \sum DF_s = 1$$

3. The fixed end moments for each span are:

- Span AB:

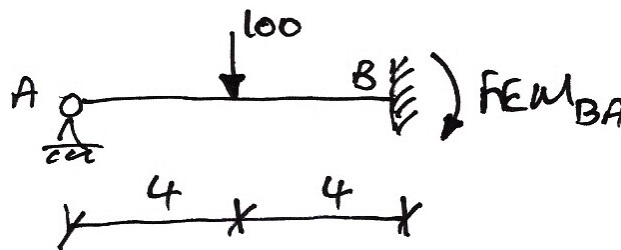

$$FEM_{BA} = -\frac{3PL}{16} = \frac{-3 \cdot 100 \cdot 8}{16} = -150 \text{ kNm}$$

Note that we consider this as a pinned-fixed beam. Example 3 explains why we do not need to consider this as a fixed-fixed beam.

- Span BC:

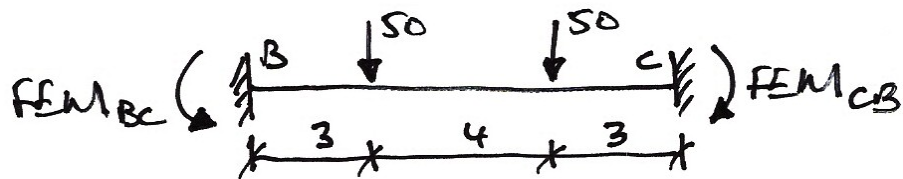

To find the fixed-end moments for this case we need to calculate the FEMs for each load separately and then use superposition to get the final result:

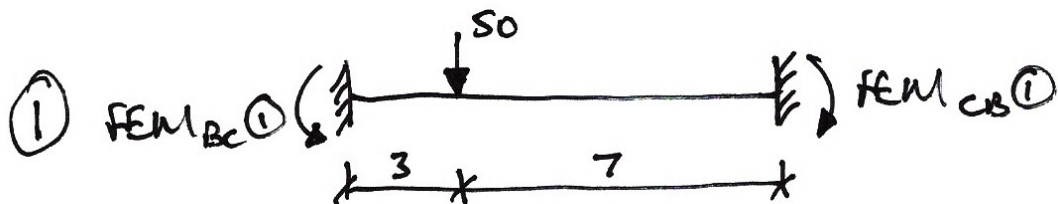

$$FEM_{BC}(1) = +\frac{Pab^2}{L^2} = +\frac{50 \cdot 3 \cdot 7^2}{10^2} = +73.5 \text{ kNm}$$

$$FEM_{CB}(1) = -\frac{Pa^2b}{L^2} = -\frac{50 \cdot 3^2 \cdot 7}{10^2} = -31.5 \text{ kNm}$$

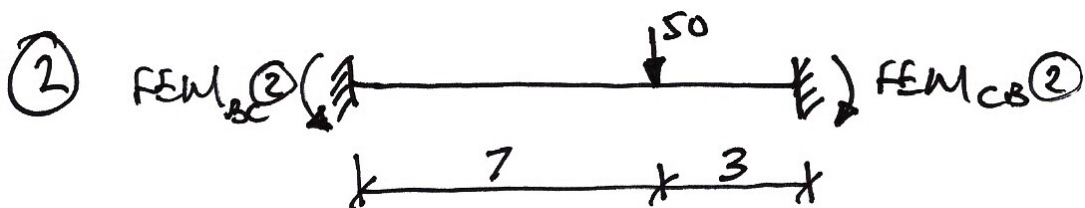

$$FEM_{BC}(2) = +\frac{Pab^2}{L^2} = +\frac{50 \cdot 7 \cdot 3^2}{10^2} = +31.5 \text{ kNm}$$

$$FEM_{CB}(2) = -\frac{Pa^2b}{L^2} = -\frac{50 \cdot 7^2 \cdot 3}{10^2} = -73.5 \text{ kNm}$$

The final FEMs are:

$$\begin{aligned} FEM_{BC}(1) &= FEM_{BC}(1) + FEM_{BC}(2) \\ &= +73.5 + 31.5 = +105 \text{ kNm} \end{aligned}$$

$$\begin{aligned} FEM_{CB}(2) &= FEM_{CB}(1) + FEM_{CB}(2) \\ &= -31.5 - 73.5 = -105 \text{ kNm} \end{aligned}$$

which is symmetrical as expected from the beam.

- Span CD:

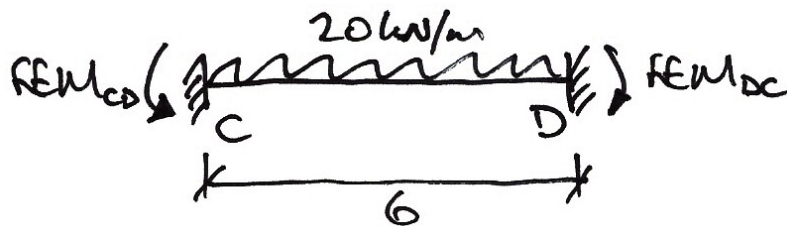

$$FEM_{CD} = +\frac{wL^2}{12} = +\frac{20 \cdot 6^2}{12} = +60 \text{ kNm}$$

$$FEM_{DC} = -\frac{wL^2}{12} = -\frac{20 \cdot 6^2}{12} = -60 \text{ kNm}$$

4. Moment Distribution Table:

Joint	A	B		C		D	
Member	AB	BA	BC	CB	CD	CB	
DF	0	0.48	0.52	0.375	0.625	1	
FEM		-150	+105	-105	+60	-60	Step 1
Dist.		+21.6	+23.4	+16.9	+28.1		Step 2
C.O.			+8.5	+11.7		+14.1	
Dist.		-4.1	-4.4	-4.4	-7.3		Step 3
C.O.			-2.2	-2.2		-3.7	
Dist.		+1.1	+1.1	+0.8	+1.4		Step 4
Final	0	-131.4	+131.4	-82.2	+82.2	-49.6	Step 5

The moments at the ends of each span are thus (noting the signs give the direction):



## Explanation of Moment Distribution Process

### Step 1

For our problem, the first thing we did was lock all of the joints:



We then established the bending moments corresponding to this locked case – these are just the fixed-end moments calculated previously:

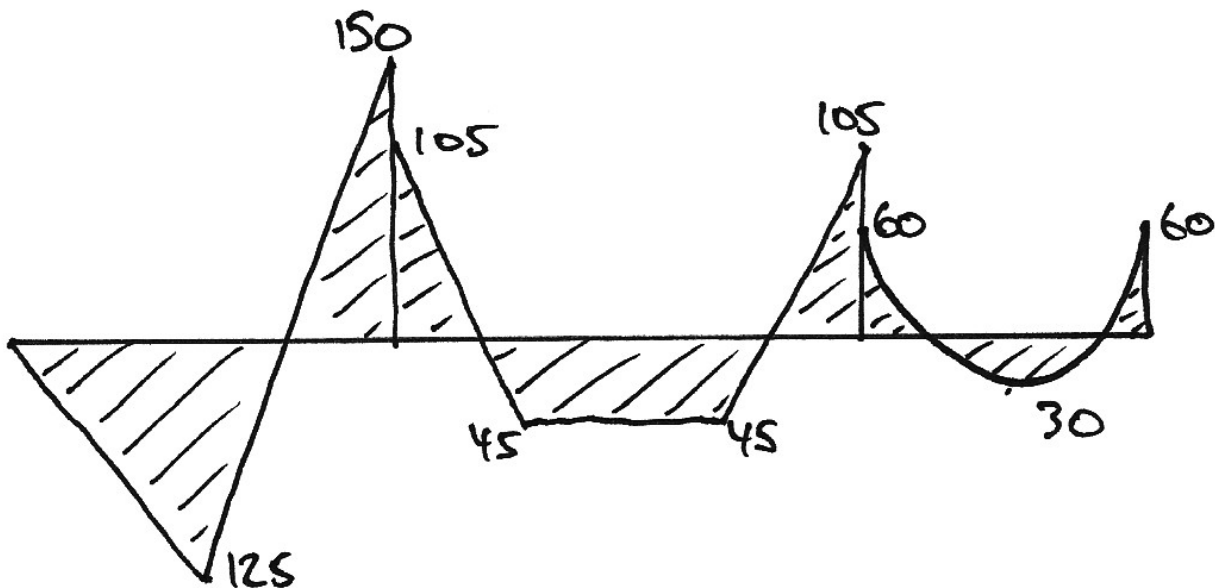

The steps or discontinuities in the bending moments at the joints need to be removed.

### Step 2 - Joint B

Taking joint *B* first, the joint is out of balance by  $-150 + 105 = -45$  kNm. We can balance this by releasing the lock and applying +45 kNm at joint *B*:

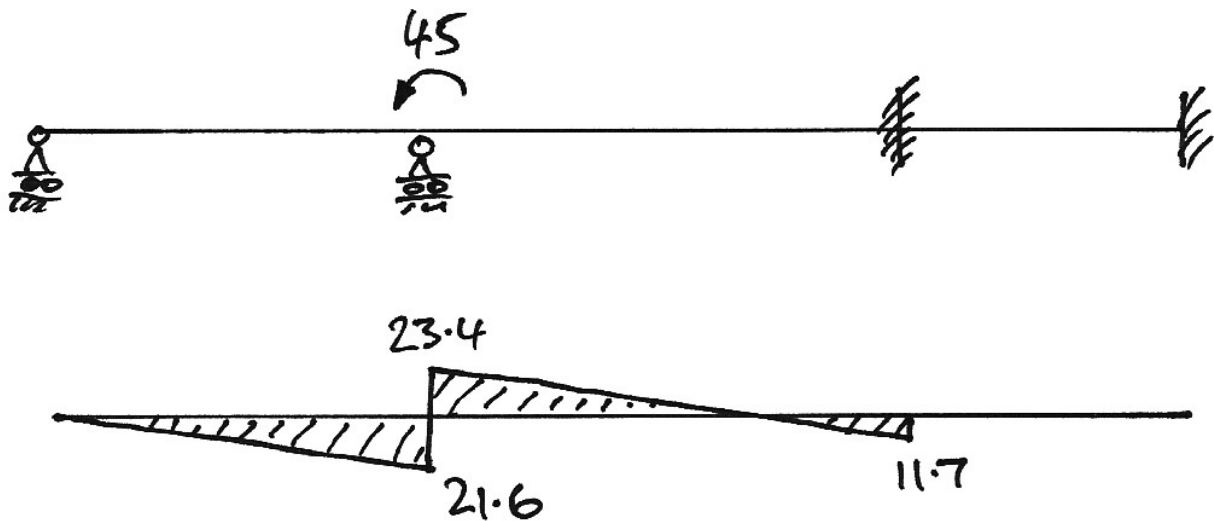

The bending moments are got as:

$$M_{BA} = 0.48 \times +45 = +21.6 \text{ kNm}$$

$$M_{BC} = 0.52 \times +45 = +23.4 \text{ kNm}$$

Also, there is a carry-over to joint C (of  $1/2 \times 23.4 = 11.4 \text{ kNm}$ ) since it is locked but no carry-over to joint A since it is a pin.

At this point we again lock joint B in its new equilibrium position.

### Step 2 - Joint C

Looking again at the beam when all joints are locked, at joint C we have an out of balance moment of  $-105 + 60 = -45 \text{ kNm}$ . We unlock this by applying a balancing moment of  $+45 \text{ kNm}$  applied at joint C giving:

$$M_{BA} = 0.375 \times +45 = +28.1 \text{ kNm}$$

$$M_{BC} = 0.625 \times +45 = +28.1 \text{ kNm}$$

And carry-overs of  $28.1 \times 0.5 = 14.1$  and  $16.9 \times 0.5 = 8.5$  (note that we're rounding to the first decimal place). The diagram for these calculations is:

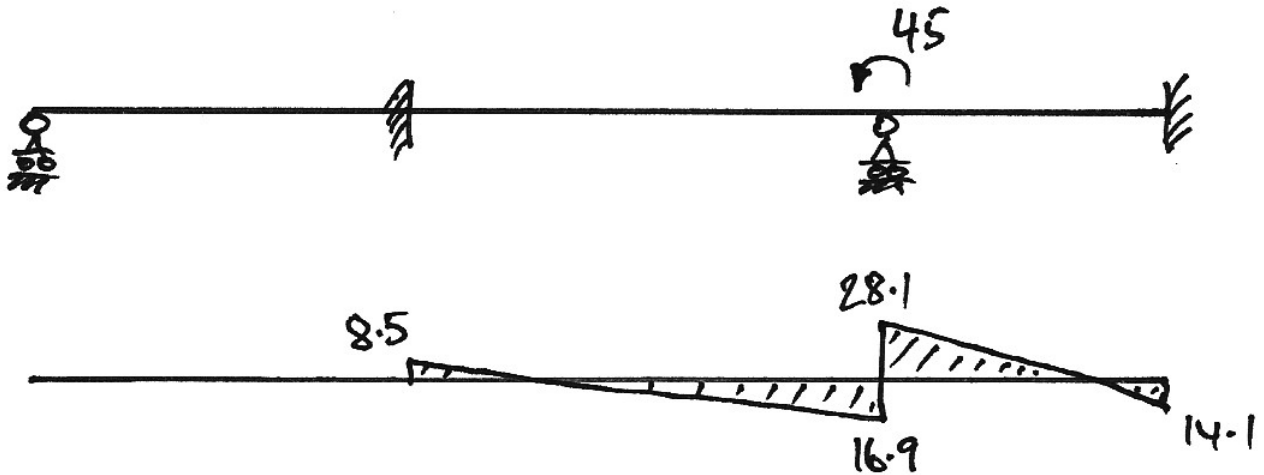

### Step 3 – Joint B

Looking back at Step 2, when we balanced joint C (and had all other joints locked) we got a carry over moment of +8.5 kNm to joint B. Therefore joint B is now out of balance again, and must be balanced by releasing it and applying -8.5 kNm to it:

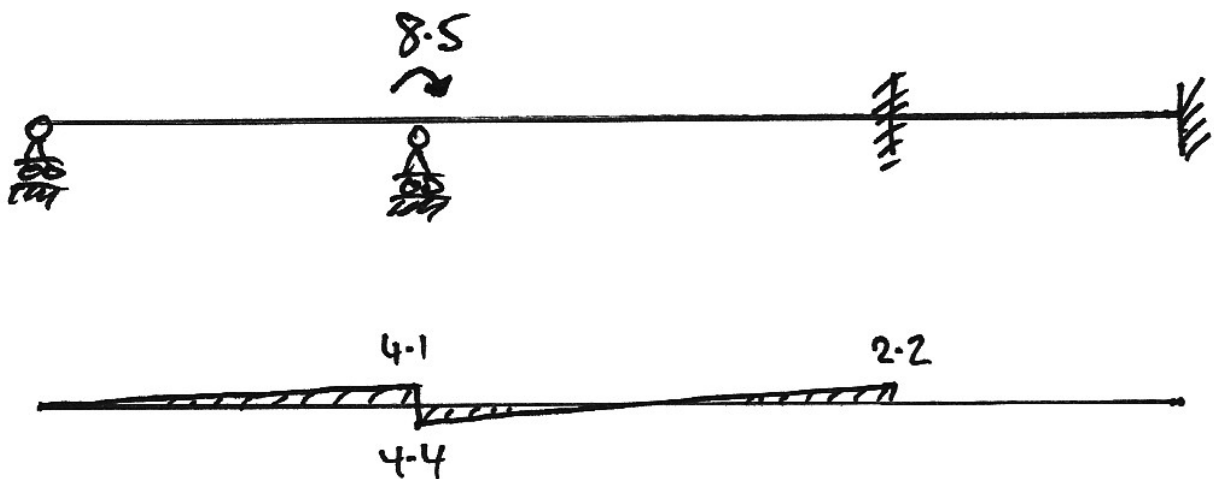

In which the figures are calculated in exactly the same way as before.

**Step 3 – Joint C**

Again, looking back at Step 2, when we balanced joint *B* (and had all other joints locked) we got a carry over moment of +11.7 kNm to joint *C*. Therefore joint *C* is out of balance again, and must be balanced by releasing it and applying -11.7 kNm to it:

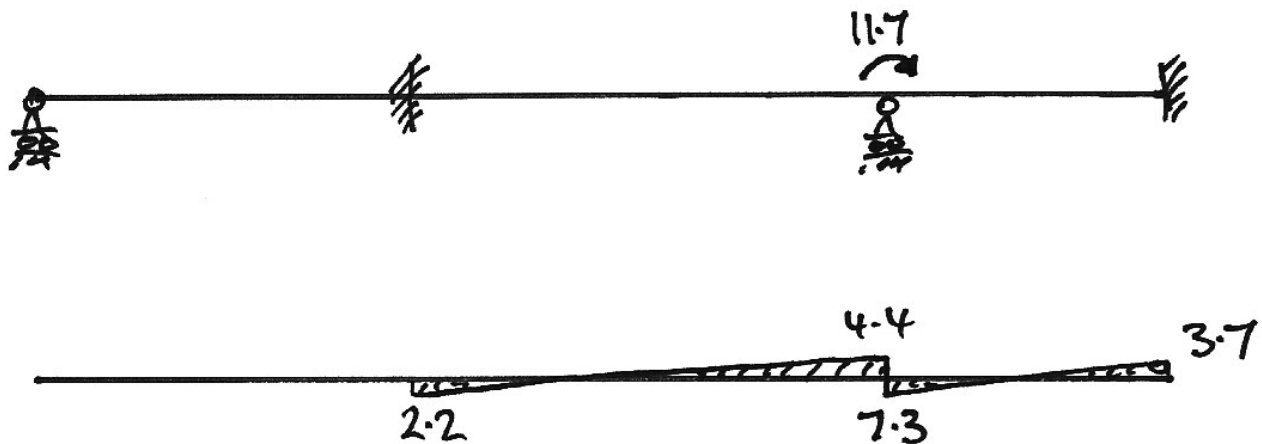

**Step 4 – Joint B**

In Step 3 when we balanced joint *C* we found another carry-over of -2.2 kNm to joint *B* and so it must be balanced again:

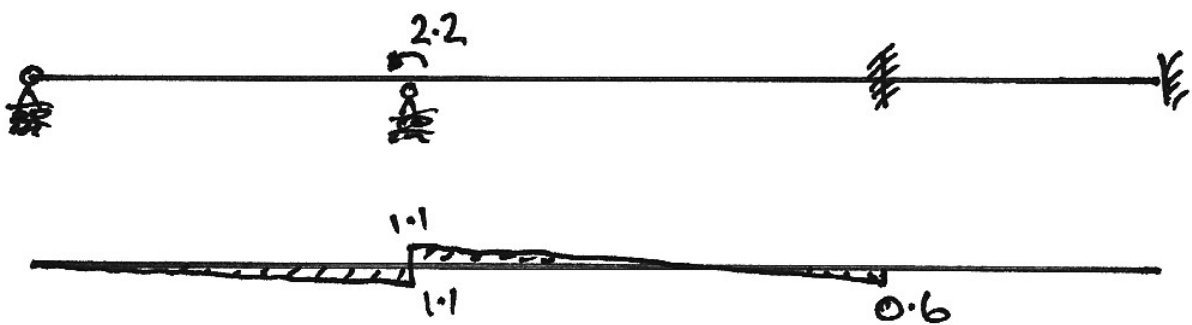

**Step 4 – Joint C**

Similarly, in Step 3 when we balanced joint *B* we found a carry-over of -2.2 kNm to joint *C* and so it must be balanced again:



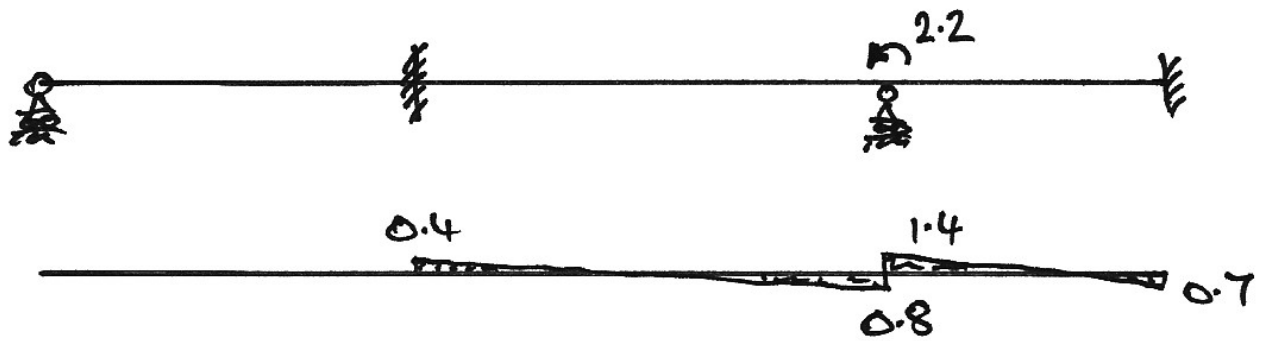

### Step 5

At this point notice that:

1. The values of the moments being carried-over are decreasing rapidly;
2. The carry-overs of Step 4 are very small in comparison to the initial fixed-end moments and so we will ignore them and not allow joints *B* and *C* to go out of balance again;
3. We are converging on a final bending moment diagram which is obtained by adding all the of the bending moment diagrams from each step of the locking/unlocking process;
4. This final bending moment diagram is obtained by summing the steps of the distribution diagrammatically, or, by summing each column in the table vertically:

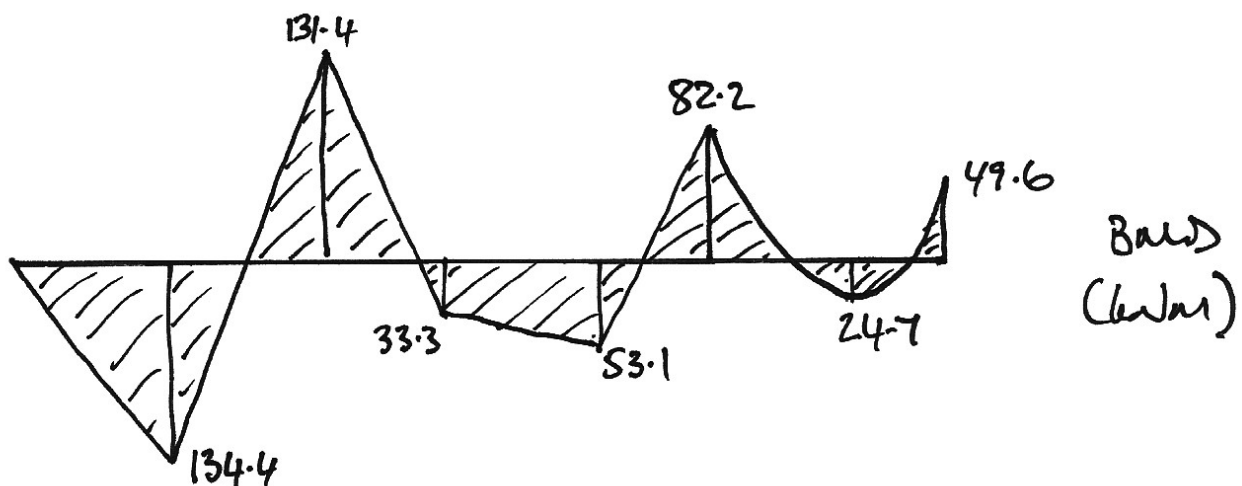

### Calculating the Final Solution

The moment distribution process gives the following results:



To this set of moments we add all of the other forces that act on each span:

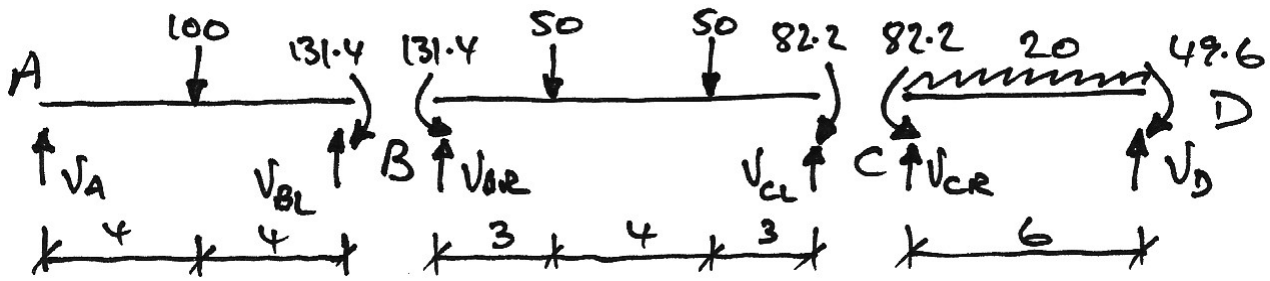

Note that at joints B and C we have separate shears for each span.

#### Span AB:

$$\sum M \text{ about } B = 0 \quad \therefore 131.4 - 100 \cdot 4 + 8V_A = 0 \quad \therefore V_A = 33.6 \text{ kN } \uparrow$$

$$\sum F_y = 0 \quad \therefore V_{BL} + 33.6 - 100 = 0 \quad \therefore V_{BL} = 66.4 \text{ kN } \uparrow$$

If we consider a free body diagram from A to mid-span we get:

$$M_{Max} = 4 \times 33.6 = 134.4 \text{ kNm}$$

#### Span BC:

$$\sum M \text{ about } B = 0 \quad \therefore 50 \cdot 3 + 50 \cdot 7 + 82.2 - 131.4 - 10V_{CL} = 0 \quad \therefore V_{CL} = 45.1 \text{ kN } \uparrow$$

$$\sum F_y = 0 \quad \therefore V_{BR} + 45.1 - 50 - 50 = 0 \quad \therefore V_{BR} = 54.9 \text{ kN } \uparrow$$

Drawing free-body diagrams for the points under the loads, we have:

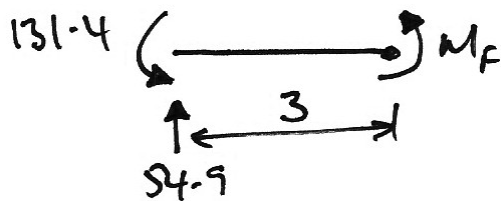

$$M_F = 54.9 \cdot 3 - 131.4 = 33.3 \text{ kNm}$$

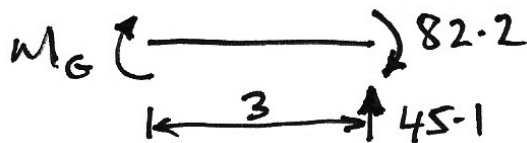

$$M_G = 45.1 \cdot 3 - 82.2 = 53.1 \text{ kNm}$$

**Span CD:**

$$\sum M \text{ about } C = 0 \quad \therefore 20 \cdot \frac{6^2}{2} + 49.6 - 82.2 - 6V_D = 0 \quad \therefore V_D = 54.6 \text{ kN } \uparrow$$

$$\sum F_y = 0 \quad \therefore V_{CR} + 54.6 - 20 \times 6 = 0 \quad \therefore V_{CR} = 65.4 \text{ kN } \uparrow$$

The maximum moment occurs at  $\frac{65.4}{20} = 3.27 \text{ m}$  from C. Therefore, we have:

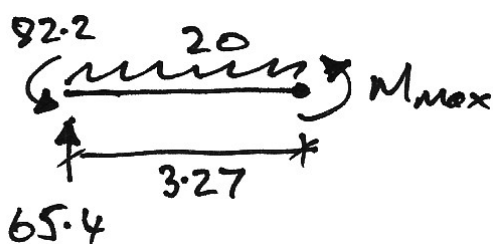

$$\sum M \text{ about } X = 0$$

$$\therefore M_{Max} + 82.2 + 20 \cdot \frac{3.27^2}{2} - 65.4 \times 3.27 = 0$$

$$\therefore M_{Max} = 24.7 \text{ kNm}$$

The total reactions at supports B and C are given by:

$$V_B = V_{BL} + V_{BR} = 66.4 + 54.9 = 121.3 \text{ kN}$$

$$V_C = V_{CL} + V_{CR} = 45.1 + 65.4 = 110.5 \text{ kN}$$

Thus the solution to the problem is summarized as:

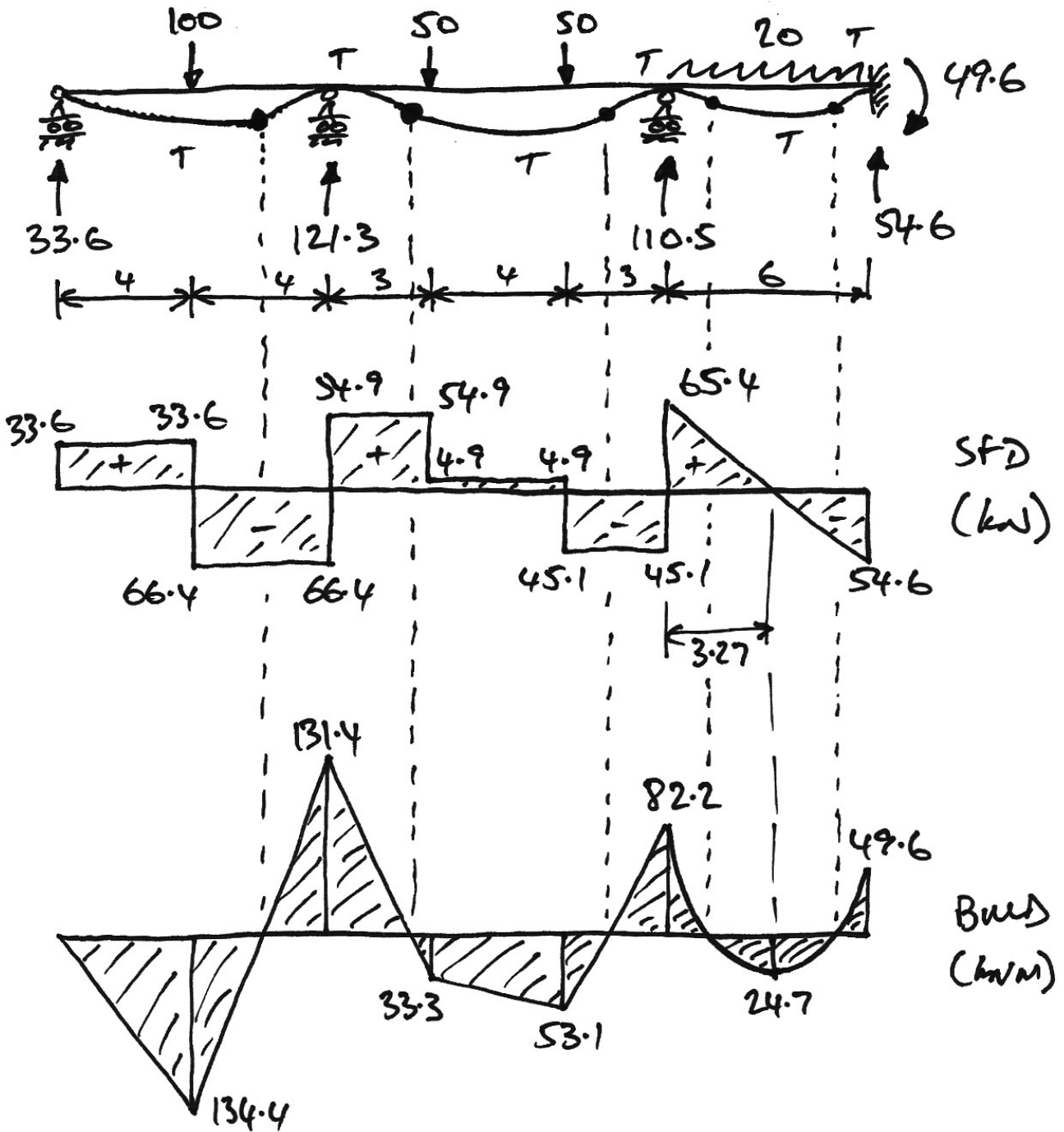

### 3.3 Example 3: Pinned End Example

In this example, we consider pinned ends and show that we can use the fixed-end moments from either a propped cantilever or a fixed-fixed beam.

We can also compare it to Example 1 and observe the difference in bending moments that a pinned-end can make.

We will analyse the following beam in two ways:

- Initially locking all joints, including support A;
- Initially locking joints except the pinned support at A.

We will show that the solution is not affected by leaving pinned ends unlocked.

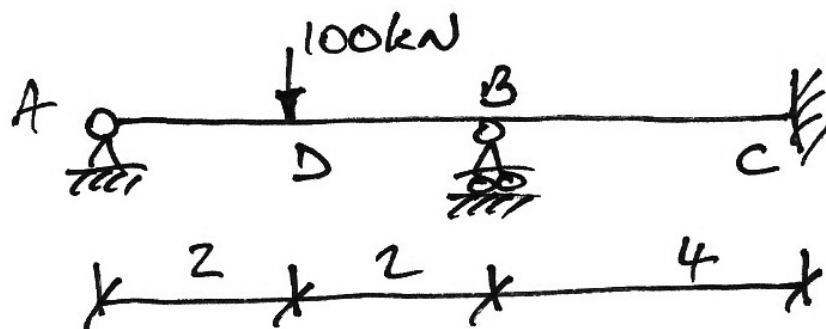

For each case it is only the FEMs that are changed; the stiffness and distribution factors are not affected. Hence we calculate these for both cases.

1. Stiffnesses:

- AB:  $k'_{BA} = \frac{3}{4} \left( \frac{EI}{L} \right)_{AB} = \frac{3}{4} \left( \frac{1}{4} \right) = \frac{3}{16}$
- BC:  $k_{BC} = \frac{1}{4}$

2. Distribution Factors:

- Joint B:

$$\sum k = \frac{3}{16} + \frac{1}{4} = \frac{7}{16}$$

$$\left. \begin{aligned} DF_{BA} &= \frac{k_{BA}}{\sum k} = \frac{3/16}{7/16} = \frac{3}{7} = 0.43 \\ DF_{BC} &= \frac{k_{BC}}{\sum k} = \frac{4/16}{7/16} = \frac{4}{7} = 0.57 \end{aligned} \right\} \sum DFs = 1$$

**Solution 1: Span AB is Fixed-Fixed**

The fixed end moments are:

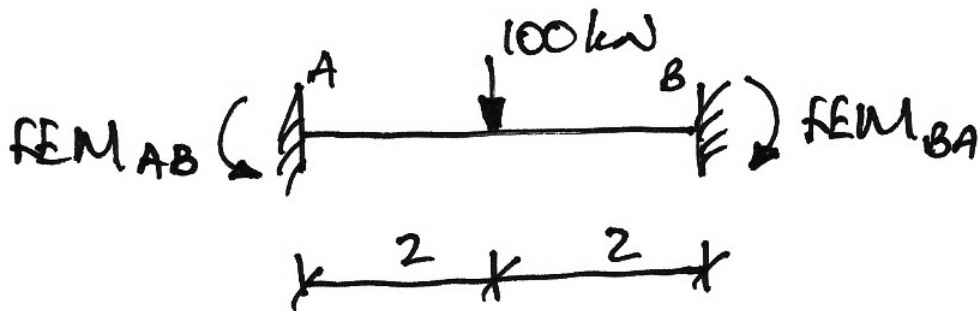

$$FEM_{AB} = +\frac{PL}{8} = \frac{+100 \cdot 4}{8} = +50 \text{ kNm}$$

$$FEM_{BA} = -\frac{PL}{8} = \frac{-100 \cdot 4}{8} = -50 \text{ kNm}$$

The distribution table is now ready to be calculated. Note that we must release the fixity at joint A to allow it return to its original pinned configuration. We do this by applying a balancing moment to cancel the fixed-end moment at the joint.

Joint	A	B		C	
Member	AB	BA	BC	CB	
DF	0	0.43	0.57	1	
FEM	+50.0	-50.0			
Pinned End	-50.0				Note 1
C.O.		-25.0			Note 2
Dist.		+32.3	+42.7		Note 3
C.O.				+21.4	Note 4
Final	0	-42.7	+42.7	+21.4	Note 5

**Note 1:**

The +50 kNm at joint A is balanced by -50 kNm. This is necessary since we should end up with zero moment at A since it is a pinned support. Note that joint B remains locked while we do this – that is, we do not balance joint B yet for clarity.

**Note 2:**

The -50 kNm balancing moment at A carries over to the far end of member AB using the carry over factor of  $+\frac{1}{2}$ .

**Note 3:**

Joint B is now out of balance by the original -50 kNm as well as the carried-over -25 kNm moment from A making a total of -75 kNm. This must be balanced by +75 kNm which is distributed as:

$$M_{BA} = DF_{BA} \cdot M_{Bal} = 0.43 \times +75 = +32.3 \text{ kNm}$$

$$M_{BC} = DF_{BC} \cdot M_{Bal} = 0.57 \times +75 = +42.7 \text{ kNm}$$

**Note 4:**

We have a carry over moment from  $B$  to  $C$  since  $C$  is a fixed end. There is no carry over moment to  $A$  since  $A$  is a pinned support.

**Note 5:**

The moments for each joint are found by summing the values vertically.

We now consider the alternative method in which we leave joint  $A$  pinned throughout.

**Solution 2: Span  $AB$  is Pinned-Fixed**

In this case the fixed-end moments are:

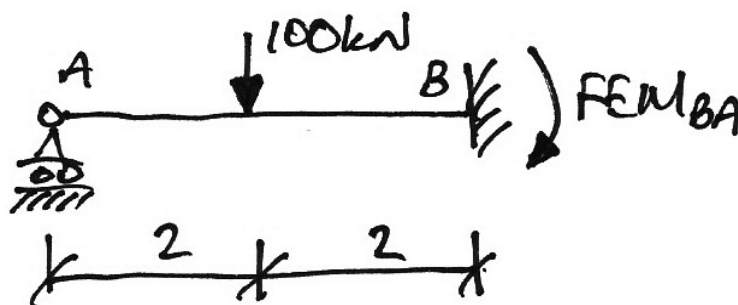

$$FEM_{BA} = -\frac{3PL}{16} = \frac{-3 \cdot 100 \cdot 4}{16} = -75 \text{ kNm}$$

The distribution table can now be calculated. Note that in this case there is no fixed-end moment at  $A$  and so it does not need to be balanced. This should lead to a shorter table as a result.



Joint	A	B		C	
Member	AB	BA	BC	CB	
DF	0	0.43	0.57	1	
FEM		-75.0			
Dist.		+32.3	+42.7		Note 1
C.O.				+21.4	Note 2
Final	0	-42.7	+42.7	+21.4	Note 3

**Note 1:**

Joint *B* is out of balance by -75 kNm. This must be balanced by +75 kNm which is distributed as:

$$M_{BA} = DF_{BA} \cdot M_{Bal} = 0.43 \times +75 = +32.3 \text{ kNm}$$

$$M_{BC} = DF_{BC} \cdot M_{Bal} = 0.57 \times +75 = +42.7 \text{ kNm}$$

**Note 2:**

We have a carry over moment from *B* to *C* since *C* is a fixed end. There is no carry over moment to *A* since *A* is a pinned support.

**Note 3:**

The moments for each joint are found by summing the values vertically.

**Conclusion**

Both approaches give the same final moments. Pinned ends can be considered as fixed-fixed which requires the pinned end to be balanced or as pinned-fixed which does not require the joint to be balanced. It usually depends on whether the fixed end moments are available for the loading type as to which method we use.

**Final Solution**

Determine the bending moment diagram, shear force diagram, reactions and draw the deflected shape for the beam as analysed.

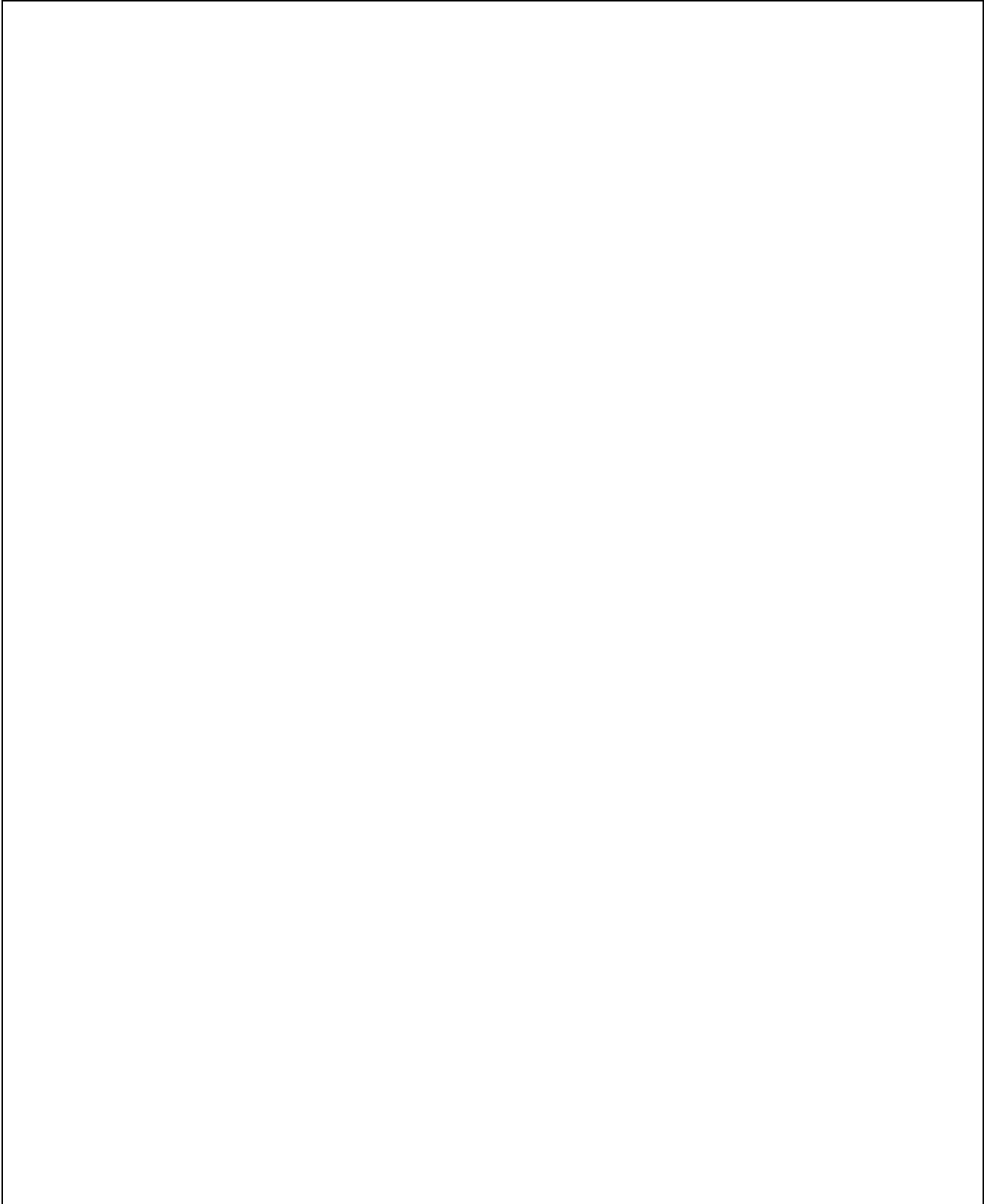

### 3.4 Example 4: Cantilever Example

#### Explanation

In this example we consider a beam that has a cantilever at one end. Given any structure with a cantilever, such as the following beam:

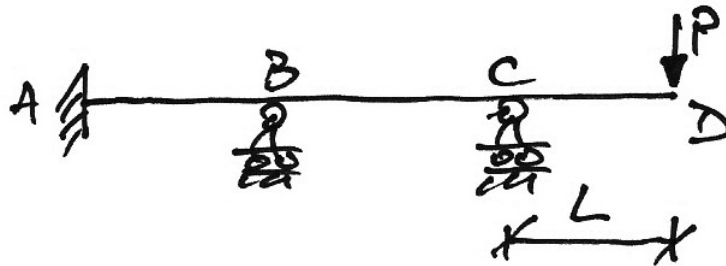

we know that the final moment at the end of the cantilever must support the load on the cantilever by statics. So for the sample beam above we must end up with a moment of  $PL$  at joint C after the full moment distribution analysis. Any other value of moment violates equilibrium.

Since we know in advance the final moment at the end of the cantilever, we do not distribute load or moments into a cantilever. Therefore a cantilever has a distribution factor of zero:

$$DF_{\text{Cantilever}} = 0$$

We implement this by considering cantilevers to have zero stiffness,  $k = 0$ . Lastly, we consider the cantilever moment as a fixed end moment applied to the joint and then balance the joint as normal. Note also that the adjacent span (e.g.  $BC$  above) does not therefore have continuity and must take the modified stiffness,  $\frac{3}{4}k$ .

**Problem Beam**

Analyse the following prismatic beam using moment distribution:

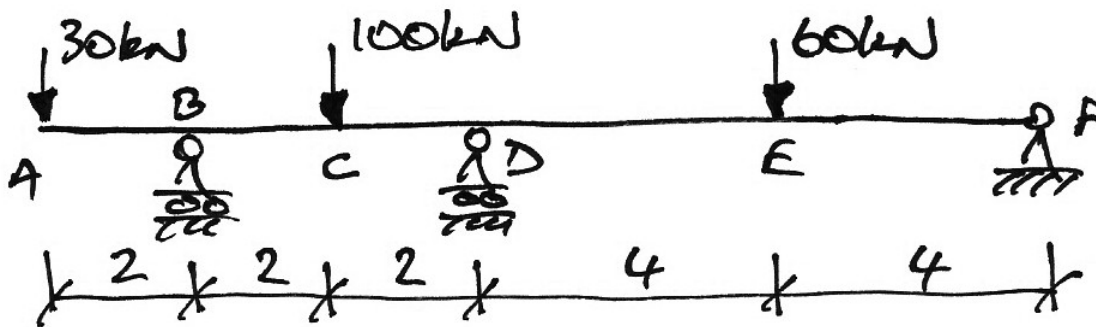

**Solution**

We proceed as before:

1. Stiffnesses:

- *AB*:  $k_{BA} = 0$  since the DF for a cantilever must end up as zero.
- *BD*: End *B* of member *BD* does not have continuity since joint *B* is free to rotate – the cantilever offers no restraint to rotation. Hence we must use the modified stiffness for member *BD*:

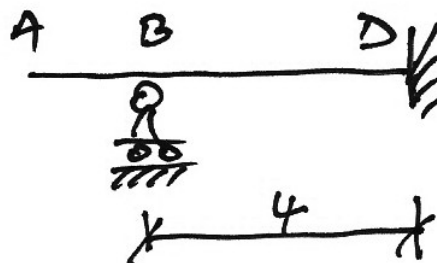

$$k'_{BD} = \frac{3}{4} \left( \frac{EI}{L} \right)_{BD} = \frac{3}{4} \left( \frac{1}{4} \right) = \frac{3}{16}$$

- *DF*:  $k'_{DF} = \frac{3}{4} \left( \frac{EI}{L} \right)_{DF} = \frac{3}{4} \left( \frac{1}{8} \right) = \frac{3}{32}$

2. Distribution Factors:

- Joint B:

$$\sum k = 0 + \frac{3}{16} = \frac{3}{16}$$

$$\left. \begin{aligned} DF_{BA} &= \frac{k_{BA}}{\sum k} = \frac{0}{3/16} = 0 \\ DF_{BD} &= \frac{k_{BD}}{\sum k} = \frac{3/16}{3/16} = 1 \end{aligned} \right\} \sum DF_s = 1$$

Notice that this will always be the case for a cantilever: the DF for the cantilever itself will be zero and for the connecting span it will be 1.

- Joint D:

$$\sum k = \frac{3}{16} + \frac{3}{32} = \frac{9}{32}$$

$$\left. \begin{aligned} DF_{DB} &= \frac{k_{DB}}{\sum k} = \frac{6/32}{9/32} = \frac{2}{3} \\ DF_{DF} &= \frac{k_{DF}}{\sum k} = \frac{3/32}{9/32} = \frac{1}{3} \end{aligned} \right\} \sum DF_s = 1$$

3. Fixed-End Moments:

As is usual, we consider each joint to be fixed against rotation and then examine each span in turn:

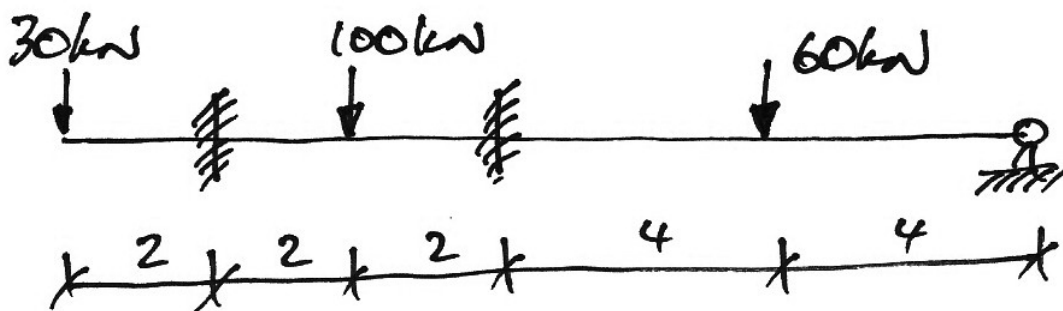

- Cantilever span  $AB$ :

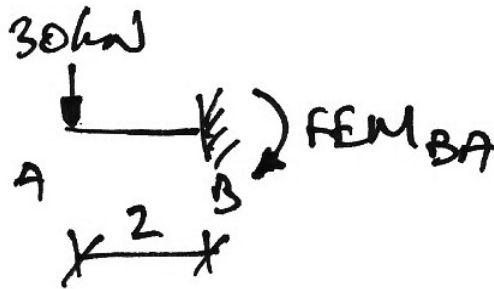

$$FEM_{BA} = -PL = -30 \cdot 2 = -60 \text{ kNm}$$

- Span  $BD$ :

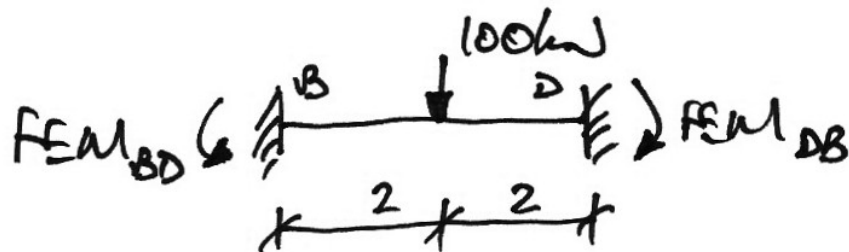

$$FEM_{BD} = +\frac{PL}{8} = \frac{+100 \cdot 4}{8} = +50 \text{ kNm}$$

$$FEM_{DB} = -\frac{PL}{8} = \frac{-100 \cdot 4}{8} = -50 \text{ kNm}$$

- Span  $DF$ :

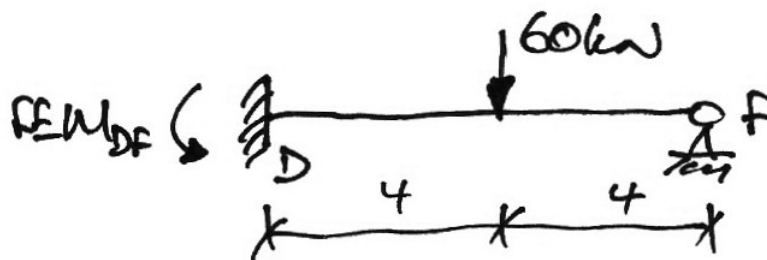

$$FEM_{DF} = +\frac{3PL}{16} = \frac{+3 \cdot 60 \cdot 8}{16} = +90 \text{ kNm}$$



### Note 2:

There is no carry-over from joint  $D$  to joint  $B$  since joint  $B$  is similar to a pinned support because of the cantilever: we know that the final moment there needs to be 60 kNm and so we don't distribute or carry over further moments to it.

### Note 3:

The +5 kNm is balanced as usual.

### Note 4:

The moments at each joint sum to zero; that is, the joints are balanced.

The moment distribution table gives the moments at the ends of each span, (noting the signs give the direction, as:

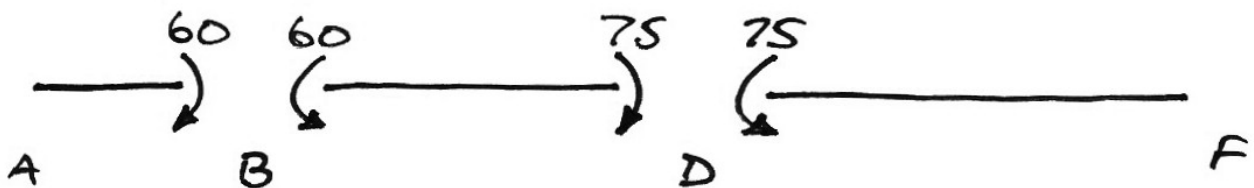

With these joint moments and statics, the final BMD, SFD, reactions and deflected shape diagram can be drawn.

### Exercise

Verify the following solution.



Final Solution

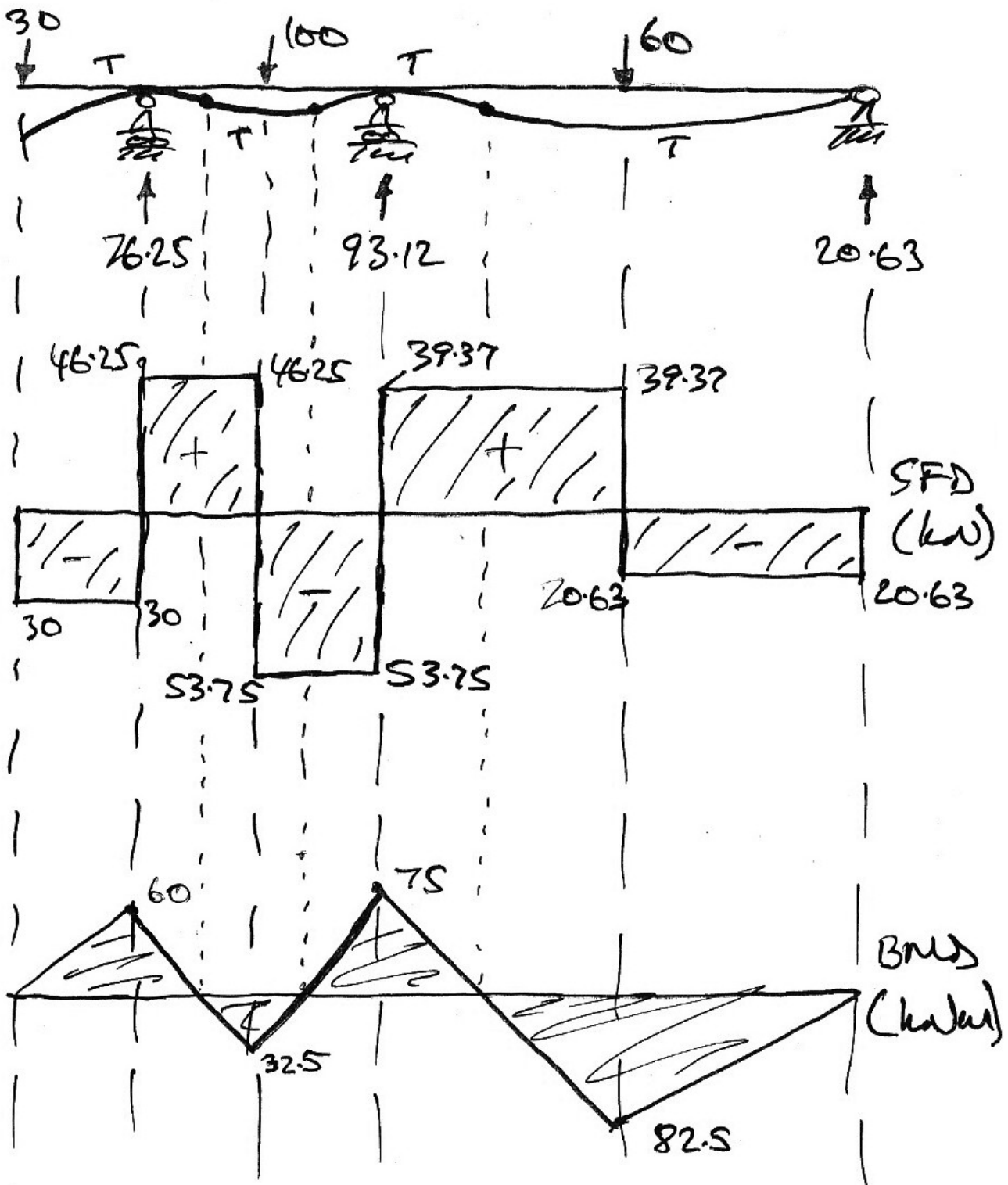

### 3.5 Example 5: Support Settlement

#### Problem

For the following beam, if support  $B$  settles by 12 mm, determine the load effects that result. Take  $E = 200 \text{ kN/mm}^2$  and  $I = 200 \times 10^6 \text{ mm}^4$ .

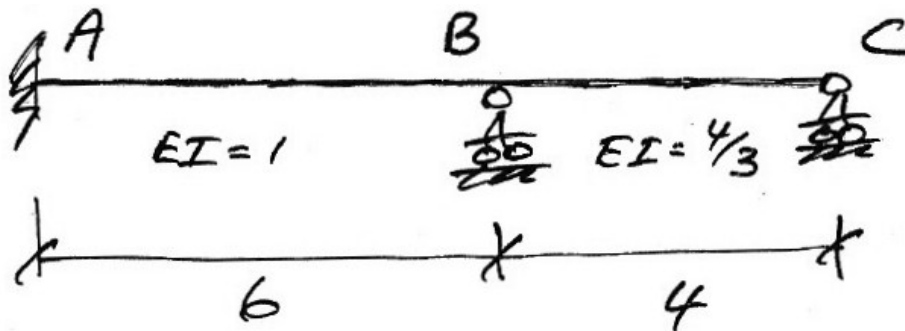

#### Solution

As with all moment distribution, we initially consider joint  $B$  locked against rotation, but the support settlement can still occur:

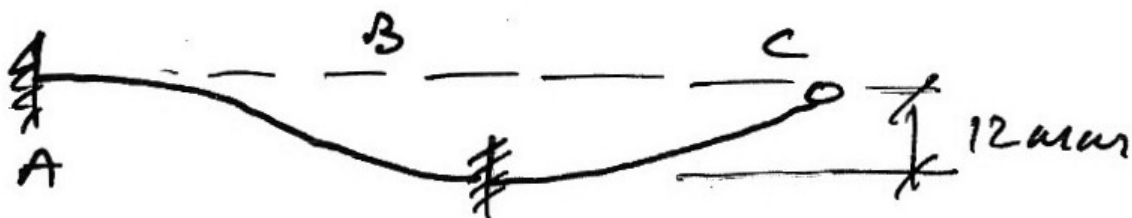

Following the normal steps, we have:

1. Stiffnesses:

- $AB$ :  $k_{BA} = \left( \frac{EI}{L} \right)_{AB} = \frac{1}{6}$
- $BC$ :  $k'_{BC} = \frac{3}{4} \left( \frac{EI}{L} \right)_{BC} = \frac{3}{4} \left( \frac{4/3}{4} \right) = \frac{1}{4}$

2. Distribution Factors:

- Joint B:

$$\sum k = \frac{1}{6} + \frac{1}{4} = \frac{10}{24}$$

$$\left. \begin{aligned} DF_{BA} &= \frac{k_{BA}}{\sum k} = \frac{4/24}{10/24} = \frac{2}{5} \\ DF_{BC} &= \frac{k_{BC}}{\sum k} = \frac{6/24}{10/24} = \frac{3}{5} \end{aligned} \right\} \sum DF_s = 1$$

3. Fixed-End Moments:

- Span AB:

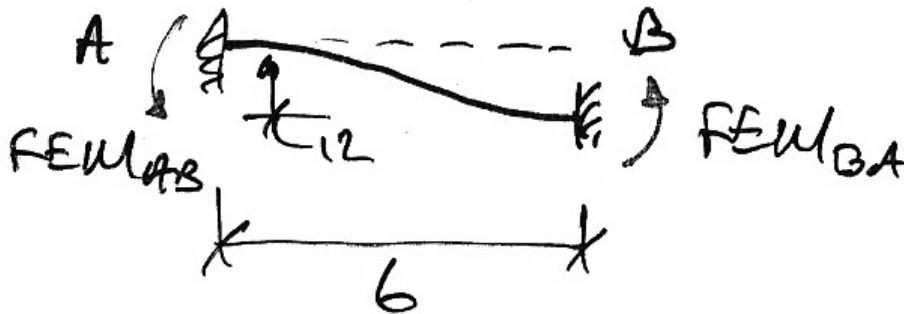

$$\begin{aligned} FEM_{AB} &= FEM_{BA} \\ &= \frac{6EI\Delta}{L^2} \\ &= \frac{6(200)(200 \times 10^6)(12 \times 10^{-3})}{(6 \times 10^3)^2} \\ &= +80 \text{ kNm} \end{aligned}$$

Note that the units are kept in terms of kN and m.

- Span BC:

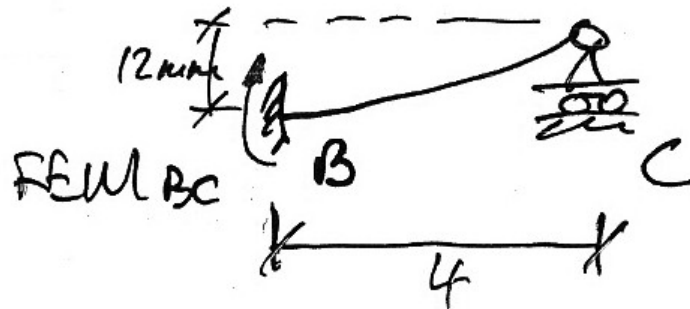

$$\begin{aligned}
 FEM_{AB} &= -\frac{3EI\Delta}{L^2} \\
 &= -\frac{3 \cdot \frac{4}{3} (200) (200 \times 10^6) (12 \times 10^{-3})}{(4 \times 10^3)^2} \\
 &= -120 \text{ kNm}
 \end{aligned}$$

Note that the  $\frac{4}{3}EI$  stiffness of member BC is important here.

4. Moment Distribution Table:

Joint	A	B		C
Member	AB	BA	BC	CB
DF	1	0.4	0.6	0
FEM	+80.0	+80.0	-120.0	
Dist.		+16.0	+24.0	
C.O.	+8.0			0
Final	+88.0	+96.0	-96.0	0

The moment distribution table gives the moments at the ends of each span, (noting the signs give the direction, as:

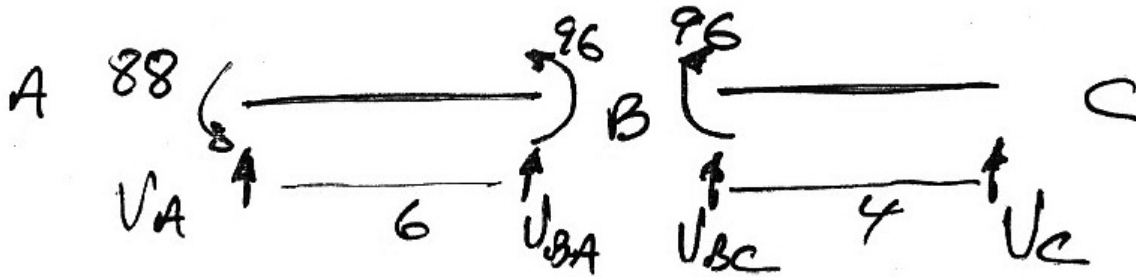

**Span AB:**

$$\sum M \text{ about } A = 0 \quad \therefore 88 + 96 + 6V_{BA} = 0$$

$$\therefore V_{BA} = -30.7 \text{ kN i.e. } \downarrow$$

$$\sum F_y = 0 \quad \therefore V_{BA} + V_A = 0$$

$$\therefore V_A = +30.7 \text{ kN } \uparrow$$

**Span BC:**

$$\sum M \text{ about } B = 0 \quad \therefore 96 - 4V_C = 0$$

$$\therefore V_C = 24.0 \text{ kN } \uparrow$$

$$\sum F_y = 0 \quad \therefore V_{BC} + V_C = 0$$

$$\therefore V_{BC} = -24.0 \text{ kN i.e. } \downarrow$$

$$V_B = V_{BA} + V_{BC} = 30.7 + 24 = 54.7 \text{ kN } \downarrow$$

Hence the final solution is as follows.

Note the following:

- unusually we have tension on the underside of the beam at the support location that has settled;
- the force required to cause the 12 mm settlement is the 54.7 kN support ‘reaction’;
- the small differential settlement of 12 mm has caused significant load effects in the structure.

Final Solution

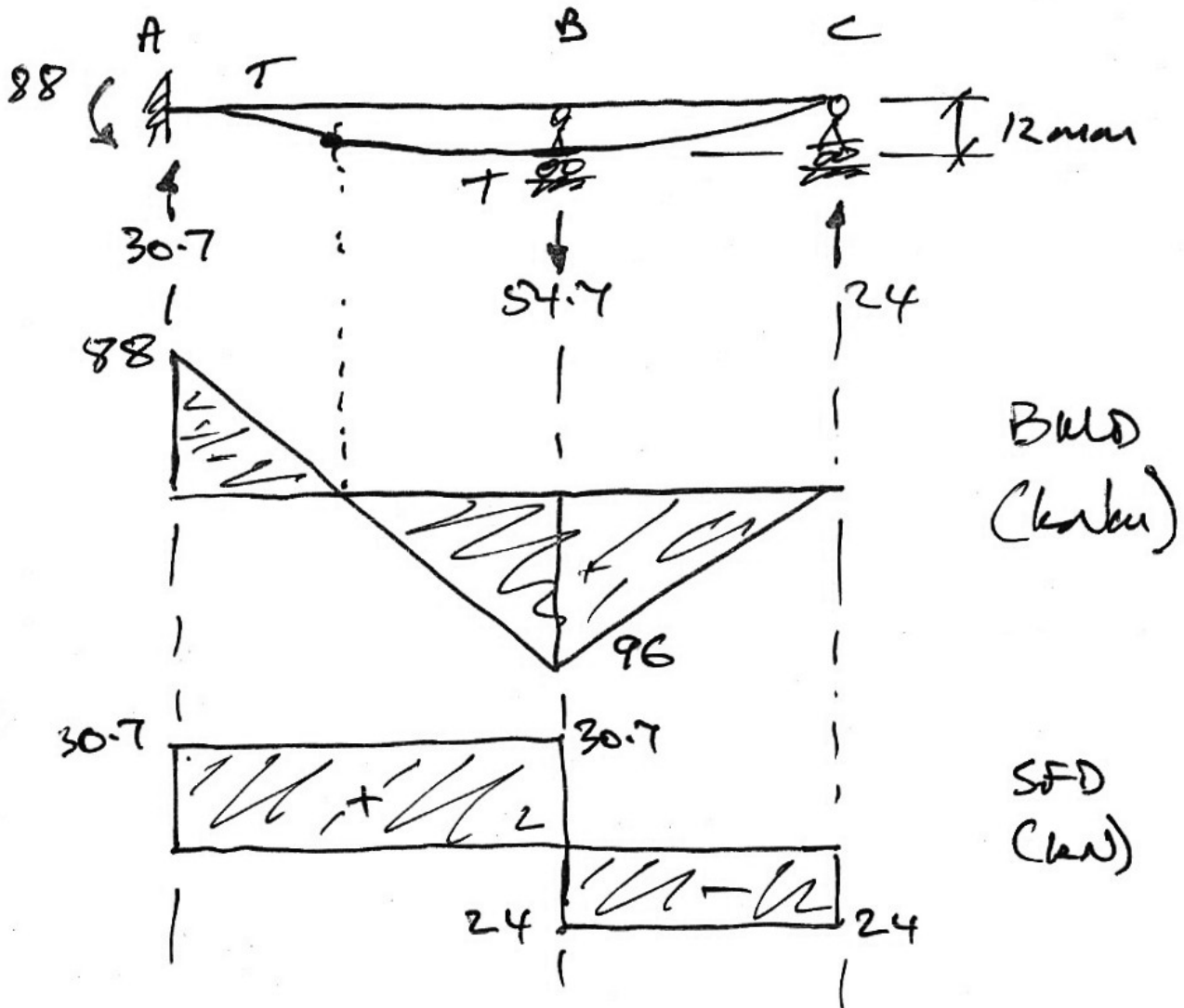

**3.6 Problems**

Using moment distribution, determine the bending moment diagram, shear force diagram, reactions and deflected shape diagram for the following beams. Consider them prismatic unless  $EI$  values are given. The solutions are given with tension on top as positive.

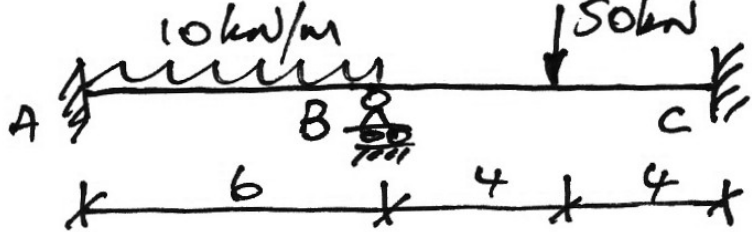
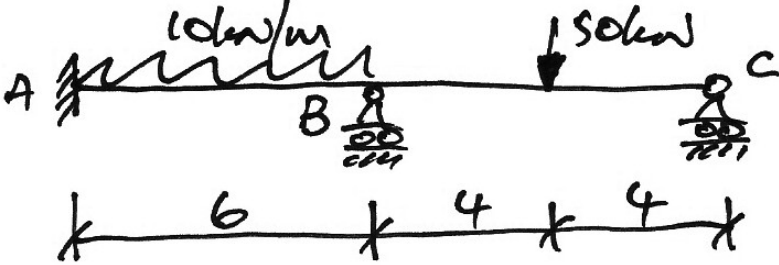
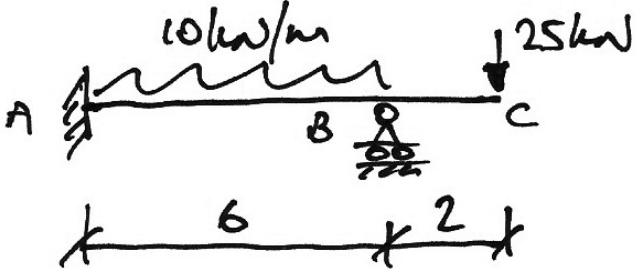
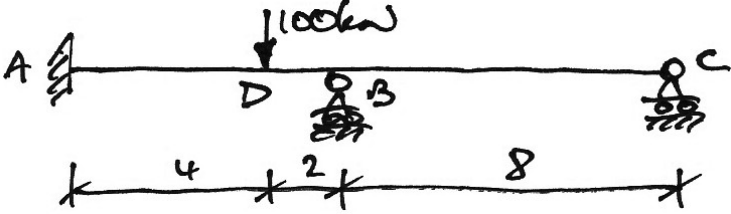
1.		<p>A: 24.3                      B: 41.4                      C: 54.3                      (kNm)</p>
2.		<p>A: 15.6                      B: 58.8                      C: 0                      (kNm)</p>
3.		<p>A: 20.0                      B: 50.0                      (kNm)</p>
4.		<p>A: 72.9                      B: 32.0                      C: 0                      (kNm)</p>

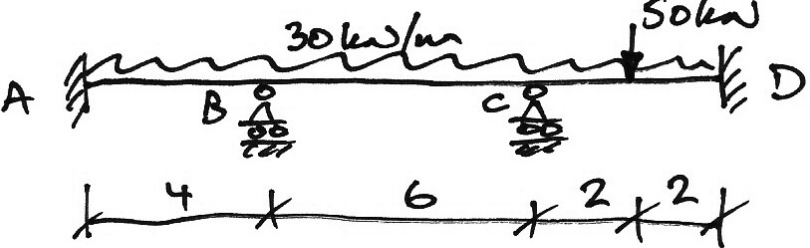
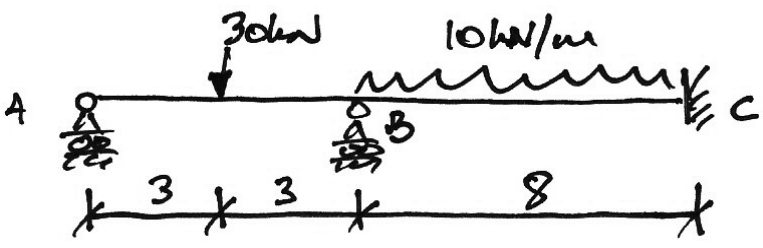
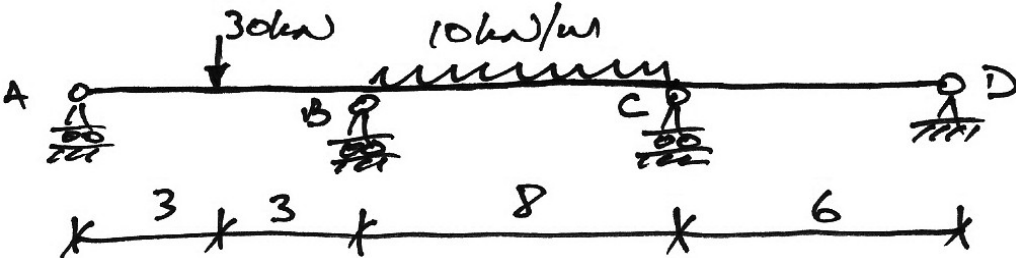
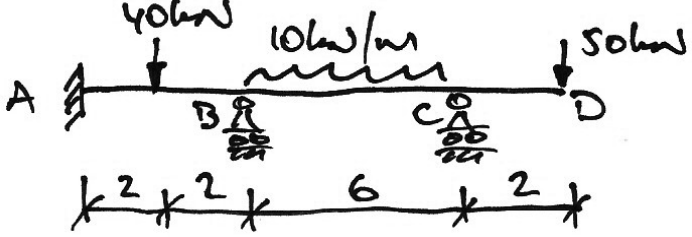
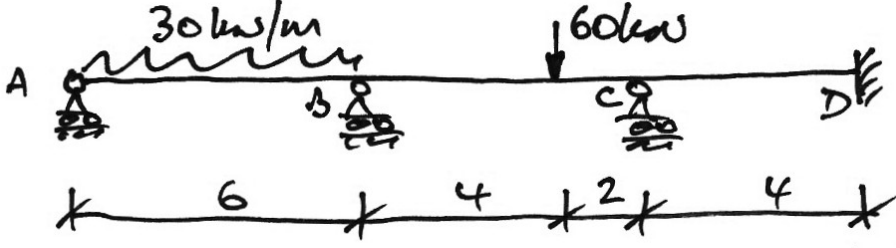
5.		<p>A: 22.8                      B: 74.4                      C: 86.9                      D: 54.1</p>
6.		<p>A: 0                      B: 43.5                      C: 58.2                      (kNm)</p>
7.	<p>Using any relevant results from Q6, analyse the following beam:</p> 	<p>A: 0                      B: 50.6                      C: 33.7                      D: 0                      (kNm)</p>
8.		<p>A: 28.3                      B: 3.3                      C: 100.0                      (kNm)</p>
9.		<p>A: 0                      B: 66.0                      C: 22.9                      D: 10.5                      (kNm)</p>



<p>10.</p>		<p>A: 0                  B: 69.2                  C: 118.6                  D: 0                  (kNm)</p>
<p>11.</p>		<p>A: -2.5                  B: 5.8                  C: 62.5                  D: 0                  (kNm)</p>
<p>12.</p>		<p>A: 85.0                  B: 70.0                  C: 70.0                  D: 0                  (kNm)</p>
<p>13.</p>		<p>A: 0                  B: 31.7                  C: 248.3                  D: 0                  (kNm)</p>
<p>14.</p>	<p>Support C also settles by 15 mm. Use <math>EI = 40 \text{ MNm}</math>.</p>	<p>A: 0                  B: 240.0                  C: -39.6                  D: 226.1                  (kNm)</p>

## 4. Non-Sway Frames

### 4.1 Introduction

Moment distribution applies just as readily to frames as it does to beams. In fact its main reason for development was for the analysis of frames. The application of moment distribution to frames depends on the type of frame:

- Braced or non-sway frame:  
Moment distribution applies readily, with no need for additional steps;
- Unbraced or sway frame:  
Moment distribution applies, but a two-stage analysis is required to account for the additional moments caused by the sway of the frame.

The different types of frame are briefly described.

### **Braced or Non-Sway Frame**

This is the most typical form of frame found in practice since sway can cause large moments in structures. Any frame that has lateral load resisted by other structure is considered braced. Some examples are:

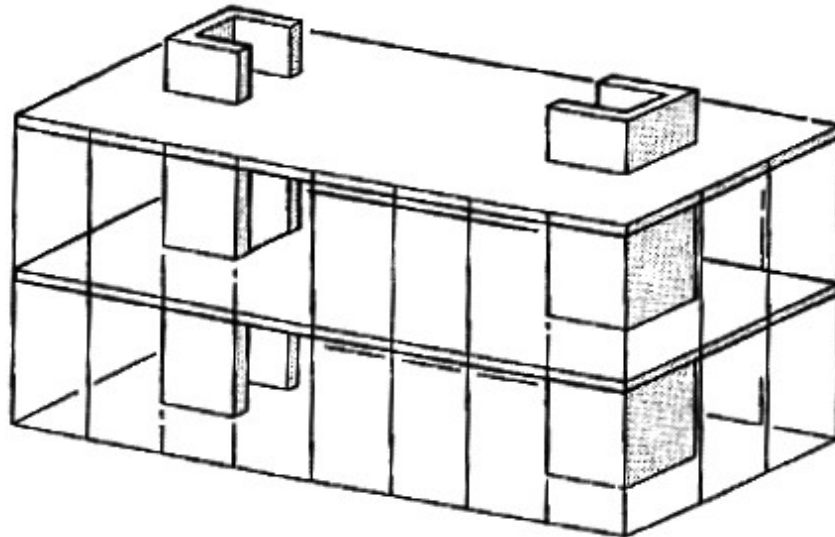

**Typical RC Braced Frame**

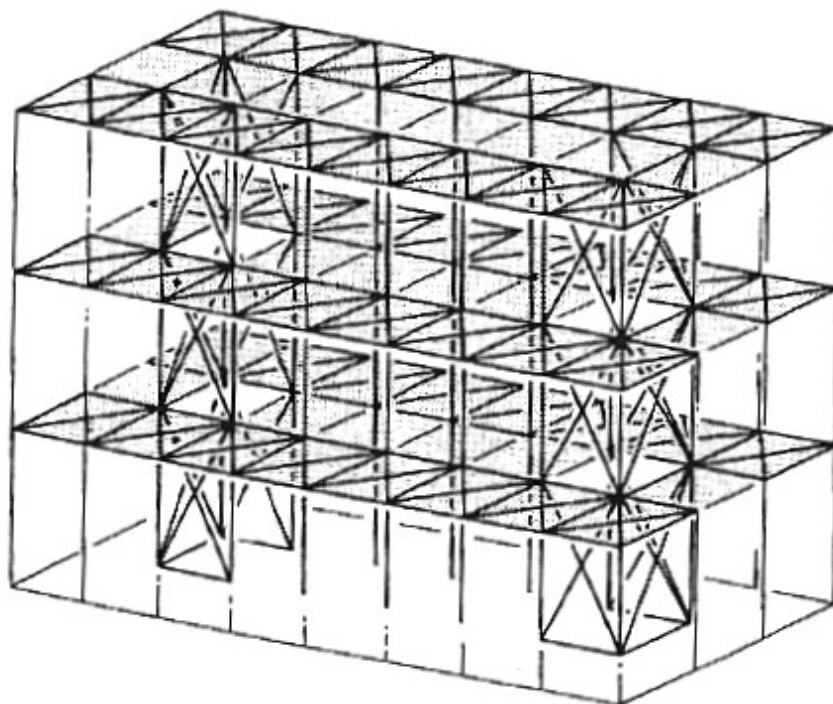

**Typical Steel Braced Frame**

In our more usual structural model diagrams:

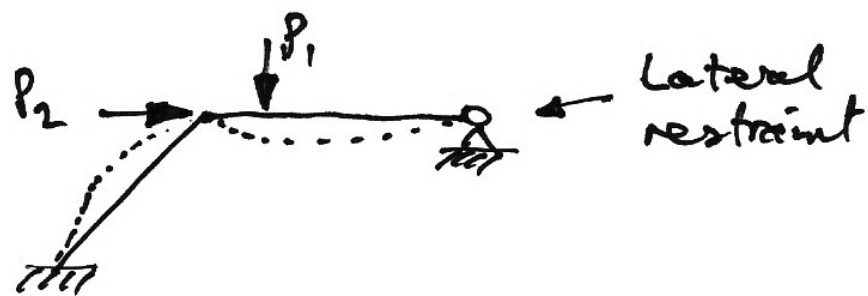
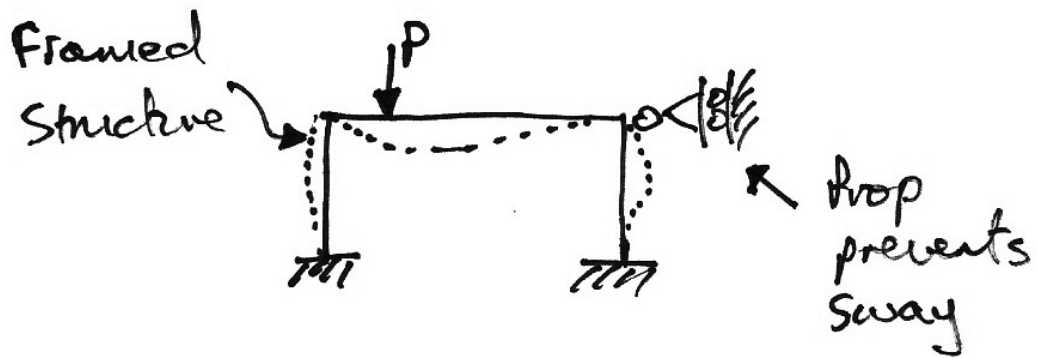

### Unbraced or Sway Frame

When a framed structure is not restrained against lateral movement by another structure, it is a sway frame. The lateral movements that result induce additional moments into the frame. For example:

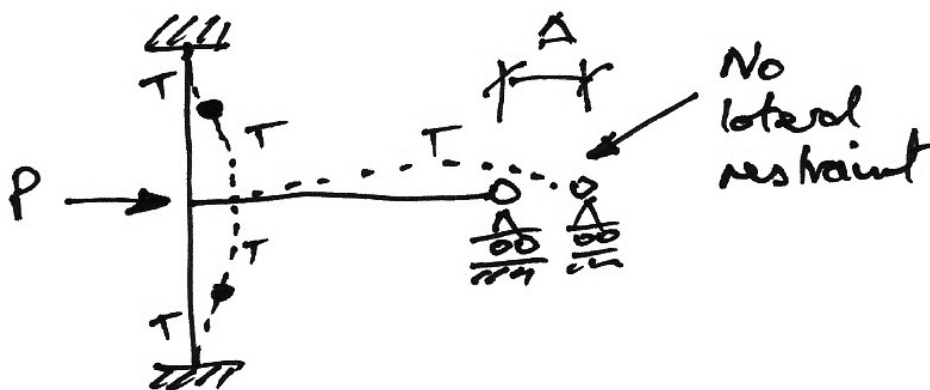
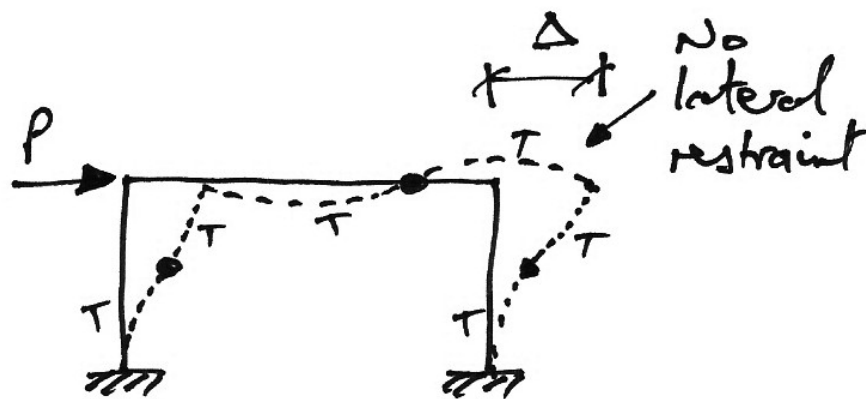
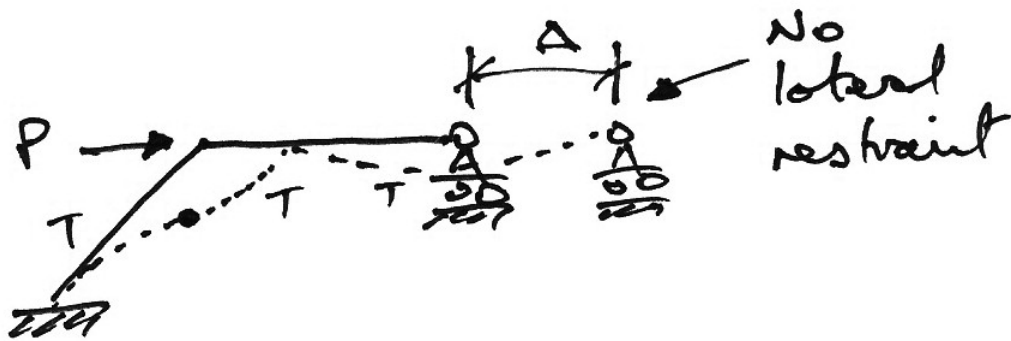

## 4.2 Example 6: Simple Frame

### Problem

Analyse the following prismatic frame for the bending moment diagram:

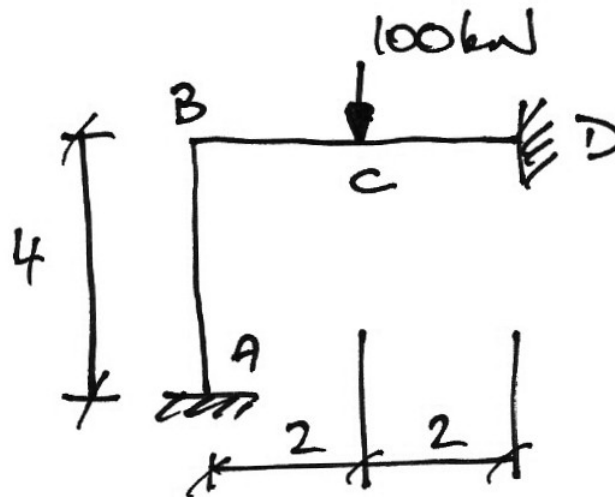

### Solution

We proceed as usual:

#### 1. Stiffnesses:

- $AB$ :  $k_{BA} = \left( \frac{EI}{L} \right)_{AB} = \frac{1}{4}$

- $BC$ :  $k_{BD} = \left( \frac{EI}{L} \right)_{BD} = \frac{1}{4}$

#### 2. Distribution Factors:

- Joint  $B$ :

$$\sum k = \frac{1}{4} + \frac{1}{4} = \frac{2}{4}$$

$$\left. \begin{aligned} DF_{BA} &= \frac{k_{BA}}{\sum k} = \frac{1/4}{2/4} = 0.5 \\ DF_{BD} &= \frac{k_{BD}}{\sum k} = \frac{1/4}{2/4} = 0.5 \end{aligned} \right\} \sum DFs = 1$$

3. Fixed-End Moments:

- Span *BD*:

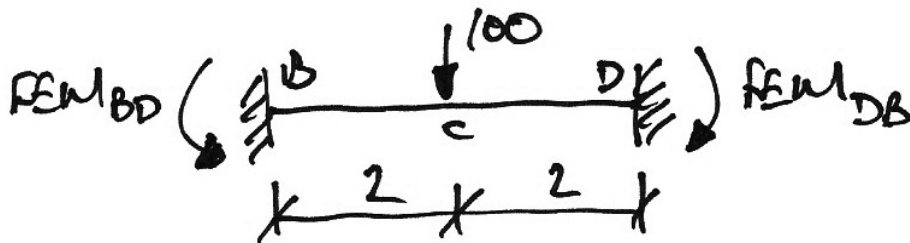

$$FEM_{BD} = +\frac{PL}{8} = \frac{+100 \cdot 4}{8} = +50 \text{ kNm}$$

$$FEM_{DB} = -\frac{PL}{8} = \frac{-100 \cdot 4}{8} = -50 \text{ kNm}$$

4. Moment Distribution Table:

Joint	A	B		D
Member	AB	BA	BD	DB
DF	0	0.5	0.5	1
FEM	0	0	+50.0	-50.0
Dist.		-25.0	-25.0	
C.O.	-12.5			-12.5
Final	-12.5	-25	+25	-62.5

Interpreting the table gives the following moments at the member ends:

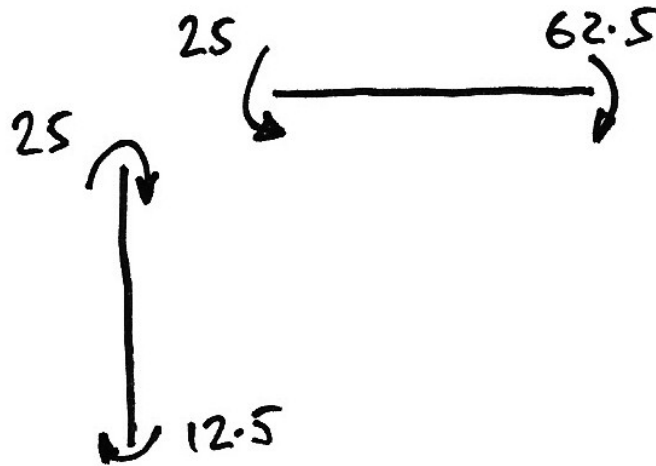

#### 5. Calculate End Shears and Forces

When dealing with frames we are particularly careful with:

- drawing the diagrams with all possible forces acting on the member;
- assuming directions for the forces;
- interpreting the signs of the answers as to the actual direction of the forces/moments.

Remember that in frames, as distinct from beams, we have the possibility of axial forces acting. We cannot ignore these, as we will see.

So for the present frame, we split up the members and draw all possible end forces/moments on each member.



**Member AB:**

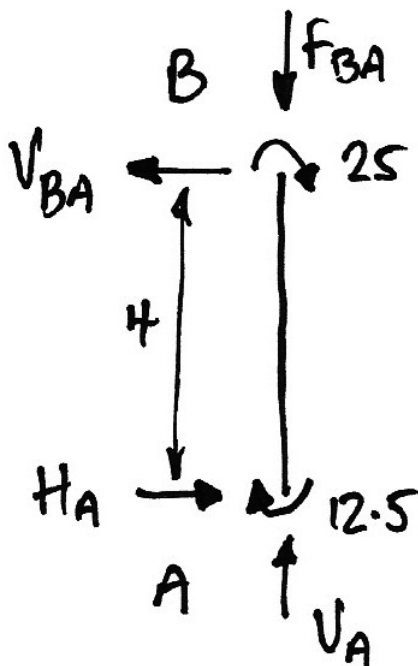

$$\sum M \text{ about } A = 0$$

$$\therefore 4V_{BA} - 12.5 - 25 = 0 \quad \therefore V_{BA} = +13.1 \text{ kN } \leftarrow$$

$$\sum F_x = 0$$

$$\therefore H_A - V_{BA} = 0 \quad \therefore H_A = +13.1 \text{ kN } \rightarrow$$

$$\sum F_y = 0$$

$$\therefore V_A - F_{BA} = 0 \quad \therefore V_A = F_{BA}$$

Notice that we cannot yet solve for the axial force in the member. It will require consideration of joint B itself.

**Member BD:**

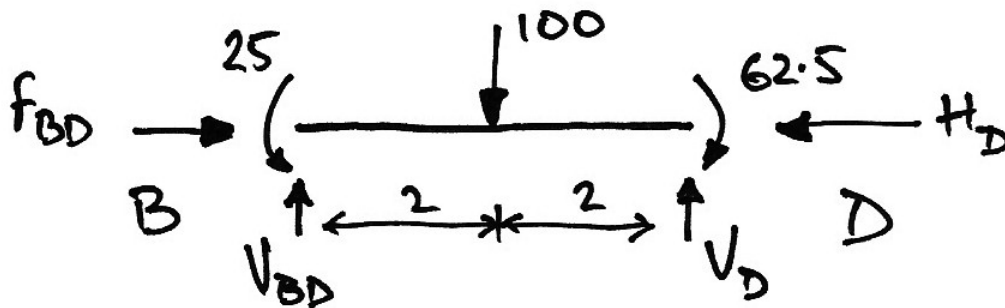

$$\sum M \text{ about } B = 0 \quad \therefore 25 - 62.5 - 100 \cdot 2 + 4V_D = 0 \quad \therefore V_D = +59.4 \text{ kN } \uparrow$$

$$\sum F_y = 0 \quad \therefore V_D + V_{BD} - 100 = 0 \quad \therefore V_{BD} = +40.6 \text{ kN } \uparrow$$

$$\sum F_x = 0 \quad \therefore H_D - F_{BD} = 0 \quad \therefore H_D = F_{BD}$$

Notice again we cannot solve for the axial force yet.

To find the moment at  $C$  in member  $BD$  we draw a free-body diagram:

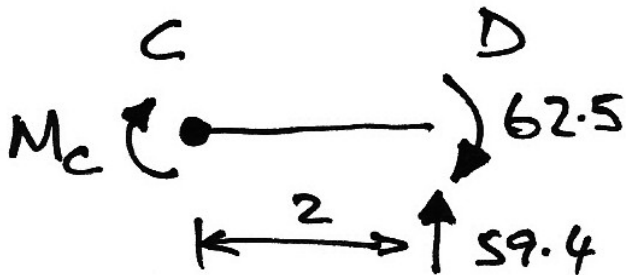

$$\begin{aligned} \sum M \text{ about } B &= 0 \\ \therefore M_C + 62.5 - 59.4 \cdot 2 &= 0 \\ \therefore M_C &= +56.3 \text{ kNm} \end{aligned}$$

To help find the axial forces in the members, we will consider the equilibrium of joint  $B$  itself. However, since there are many forces and moments acting, we will consider each direction/sense in turn:

- Vertical equilibrium of joint  $B$ :

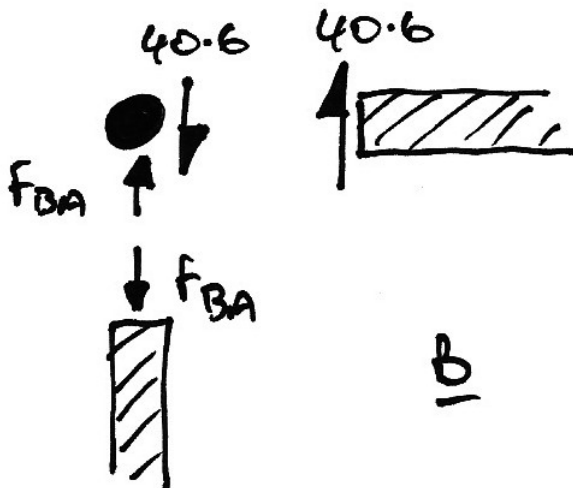

The 40.6 kN is the shear on member  $BD$ .

$$\begin{aligned} \sum F_y &= 0 \\ \therefore 40.6 - F_{BA} &= 0 \\ \therefore F_{BA} &= +40.6 \text{ kN} \end{aligned}$$

The positive sign indicates it acts in the direction shown upon the member and the joint.

- Horizontal equilibrium of joint *B*:

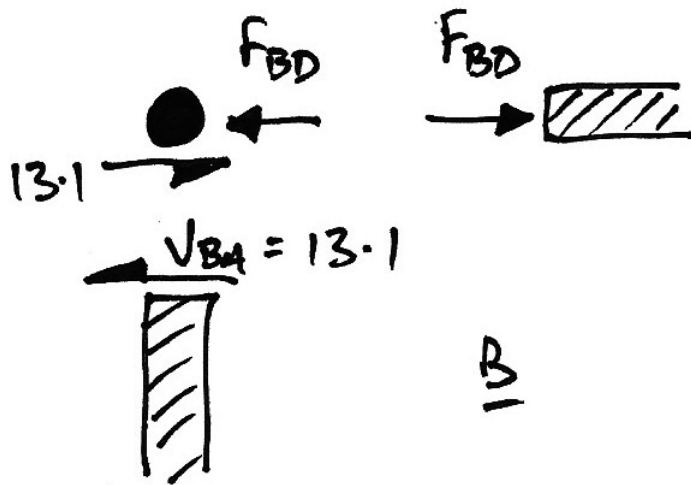

$$\begin{aligned} \sum F_x &= 0 \\ \therefore 13.1 - F_{BD} &= 0 \\ \therefore F_{BD} &= +13.1 \text{ kN} \end{aligned}$$

The positive sign indicates it acts in the direction shown upon the member and the joint.

Lastly, we will consider the moment equilibrium of the joint for completeness.

- Moment equilibrium of joint *B*:

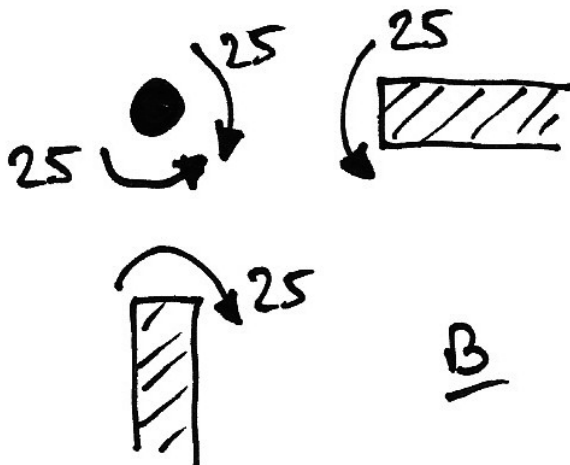

As can be seen clearly the joint is in moment equilibrium.

Assembling all of these calculations, we can draw the final solution for this problem.

Final Solution

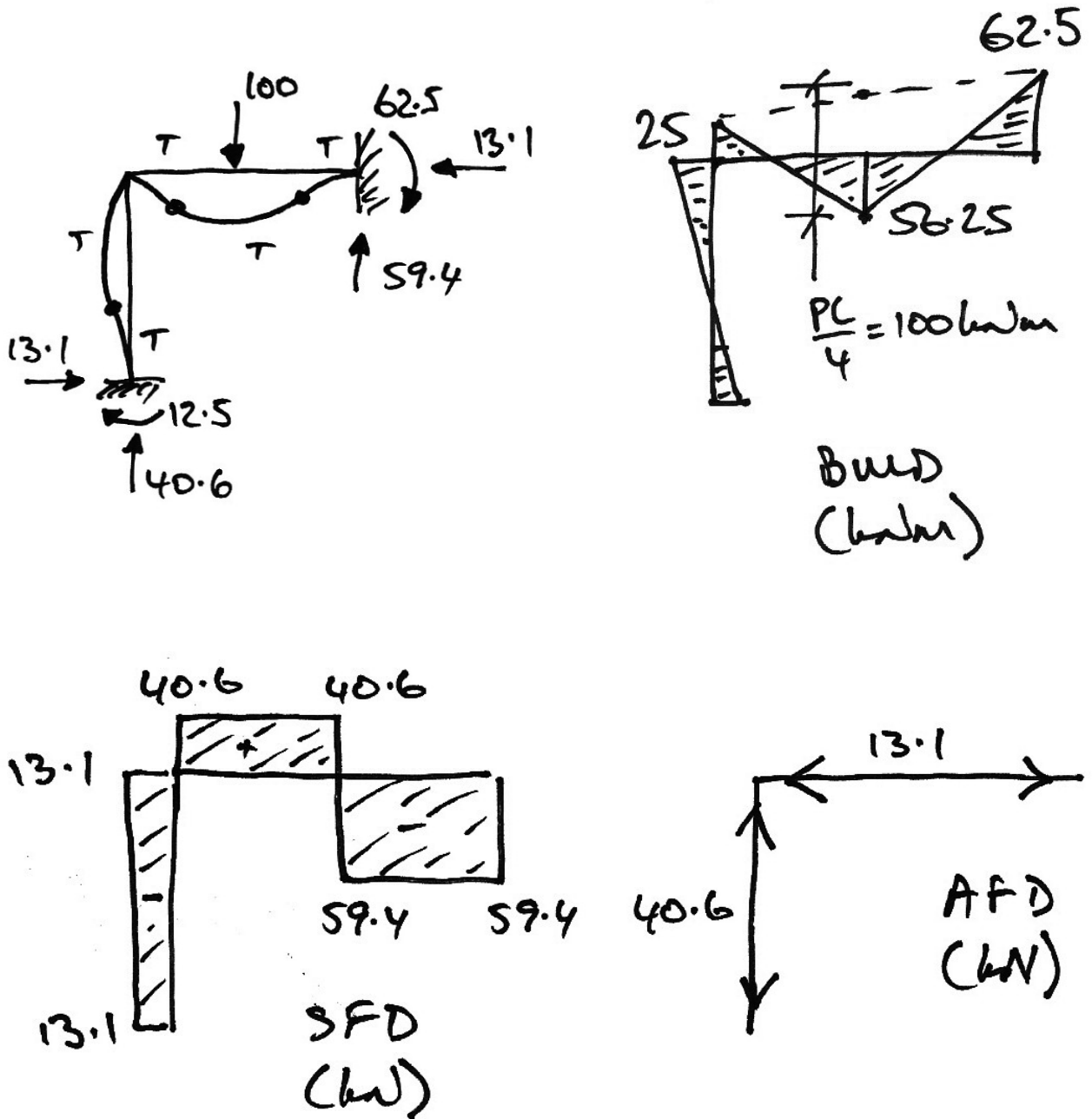

In the axial force diagram we have used the standard truss sign convention:

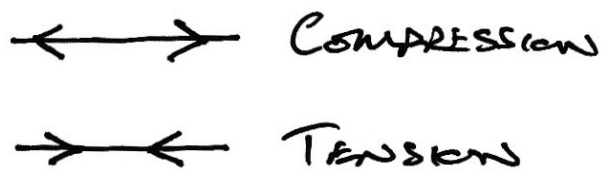

### 4.3 Example 7: Frame with Pinned Support

#### Problem

Analyse the following frame:

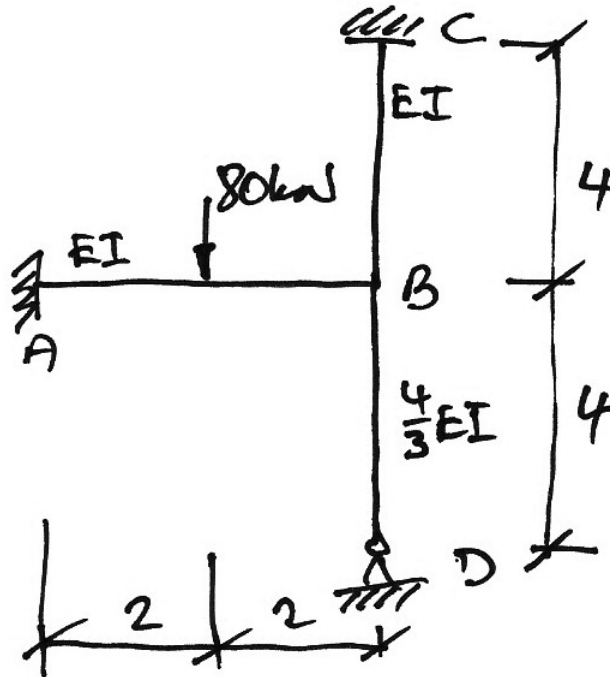

#### Solution

1. Stiffnesses:

- $AB$ :  $k_{BA} = \left( \frac{EI}{L} \right)_{AB} = \frac{1}{4}$
- $BC$ :  $k_{BC} = \left( \frac{EI}{L} \right)_{BC} = \frac{1}{4}$
- $BD$ :  $k'_{BD} = \frac{3}{4} \left( \frac{EI}{L} \right)_{BD} = \frac{3}{4} \cdot \frac{4/3}{4} = \frac{1}{4}$

2. Distribution Factors:

- Joint  $B$ :

$$\sum k = \frac{1}{4} + \frac{1}{4} + \frac{1}{4} = \frac{3}{4}$$

$$\left. \begin{aligned} DF_{BA} &= \frac{k_{BA}}{\sum k} = \frac{1/4}{3/4} = 0.33 \\ DF_{BC} &= \frac{k_{BC}}{\sum k} = \frac{1/4}{3/4} = 0.33 \\ DF_{BD} &= \frac{k_{BD}}{\sum k} = \frac{1/4}{3/4} = 0.33 \end{aligned} \right\} \sum DFs = 1$$

3. Fixed-End Moments:

- Span AB:

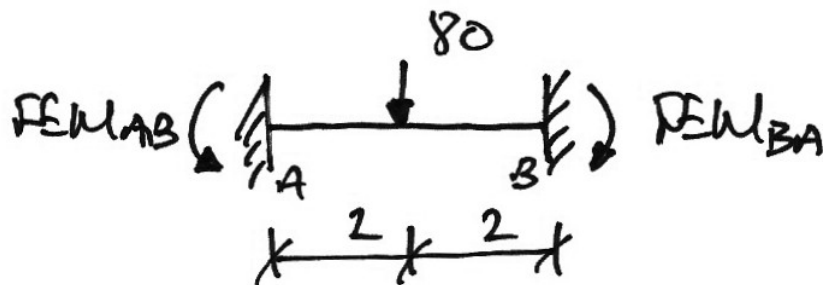

$$FEM_{AB} = +\frac{PL}{8} = \frac{+80 \cdot 4}{8} = +40 \text{ kNm}$$

$$FEM_{BA} = -\frac{PL}{8} = \frac{-80 \cdot 4}{8} = -40 \text{ kNm}$$

4. Moment Distribution Table:

Joint	A		B		C	D
Member	AB	BA	BD	BC	CB	DB
DF	0	0.33	0.33	0.33	1	0
FEM	+40.0	-40.0				
Dist.		+13.3	+13.3	+13.3		
C.O.	+6.7				+6.7	
Final	+46.7	-26.7	+13.3	+13.3	+6.7	0

The results of the moment distribution are summed up in the following diagram, in which the signs of the moments give us their directions:

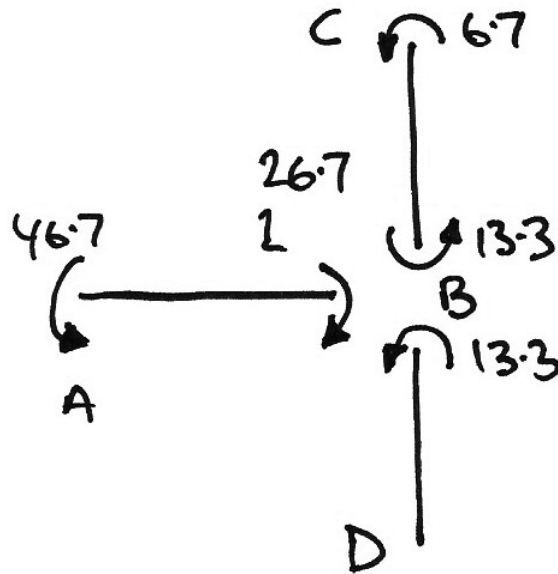

Using the above diagram and filling in the known and unknown forces acting on each member, we can calculate the forces and shears on each member.

5. Calculate End Shears and Forces

Span AB:

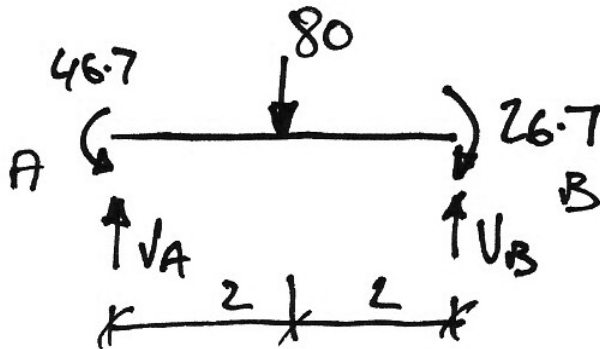

$$\sum M \text{ about } A = 0$$

$$\therefore -46.7 + 80 \cdot 2 + 26.7 - 4V_B = 0$$

$$\therefore V_B = +35.0 \text{ kN } \uparrow$$

$$\sum F_y = 0$$

$$\therefore V_B + V_A - 80 = 0$$

$$\therefore V_A = +45.0 \text{ kN } \uparrow$$

Span BC:

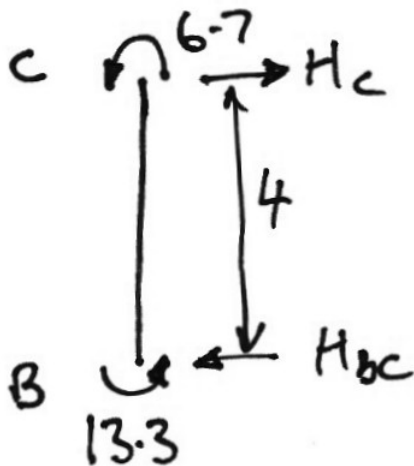

$$\sum M \text{ about } B = 0$$

$$\therefore 4H_C - 6.7 - 13.3 = 0$$

$$\therefore H_C = +5.0 \text{ kN } \rightarrow$$

$$\sum F_x = 0$$

$$\therefore H_C - H_{BC} = 0$$

$$\therefore H_{BC} = +5.0 \text{ kN } \leftarrow$$

Span BD:

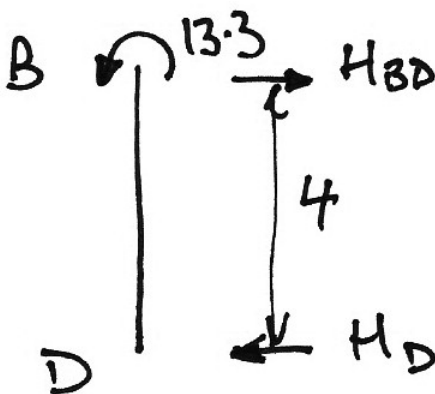

$$\sum M \text{ about } B = 0$$

$$\therefore 4H_D - 13.3 = 0$$

$$\therefore H_D = +3.3 \text{ kN } \leftarrow$$

$$\sum F_x = 0$$

$$\therefore H_D - H_{BD} = 0$$

$$\therefore H_{BD} = +3.3 \text{ kN } \rightarrow$$



To help find the axial forces in the members, consider first the vertical equilibrium of joint  $B$ :

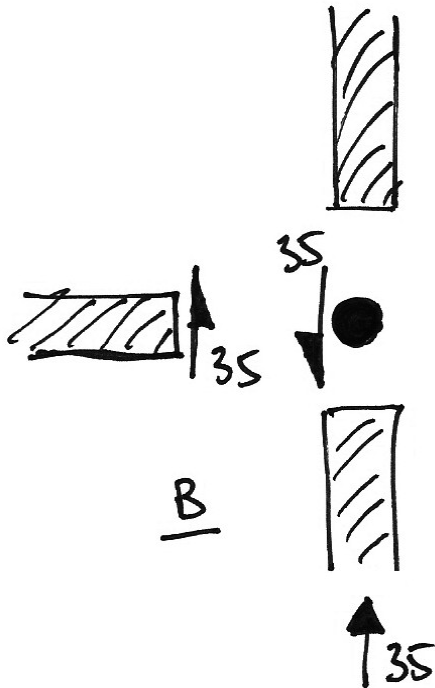

- As can be seen, the upwards end shear of 35 kN in member  $AB$  acts downwards upon joint  $B$ .
- In turn, joint  $B$  must be vertically supported by the other members.
- Since all loads must go to ground, all of the 35 kN is taken in compression by member  $BD$  as shown.

Next consider the horizontal equilibrium of joint  $B$ :

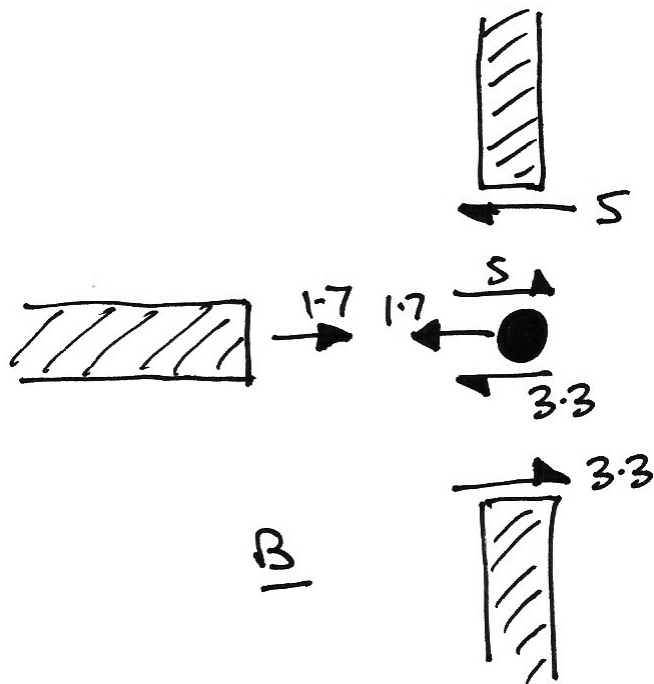

- The two ends shears of 5 kN (member  $BC$ ) and 3.3 kN (member  $BD$ ), in turn act upon the joint.
- Since joint  $B$  must be in horizontal equilibrium, there must be an extra force of 1.7 kN acting on the joint as shown.
- This 1.7 kN force, in turn, acts upon member  $AB$  as shown, resulting in the horizontal reaction at joint  $A$  of 1.7 kN.

Lastly, for completeness, we consider the moment equilibrium of joint *B*:

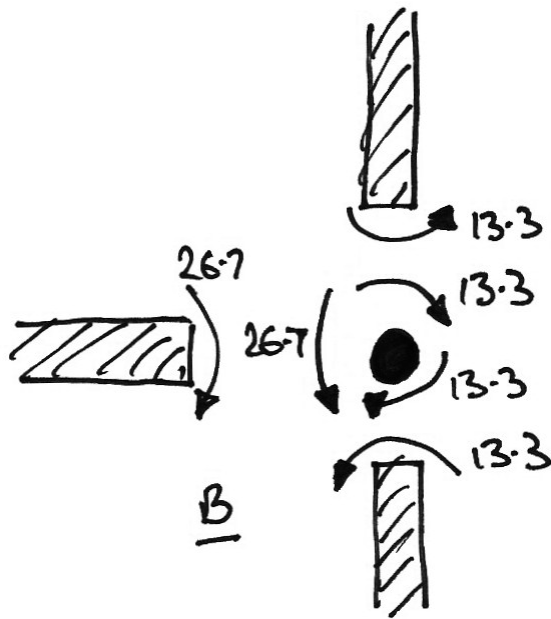

- As can be seen, the member end moments act upon the joint in the opposite direction.
- Looking at the joint itself it is clearly in equilibrium since:

$$26.7 - 13.3 - 13.3 \approx 0$$

(allowing for the rounding that has occurred).

**Final Solution**

At this point the final BMD, SFD, reactions and DSD can be drawn:

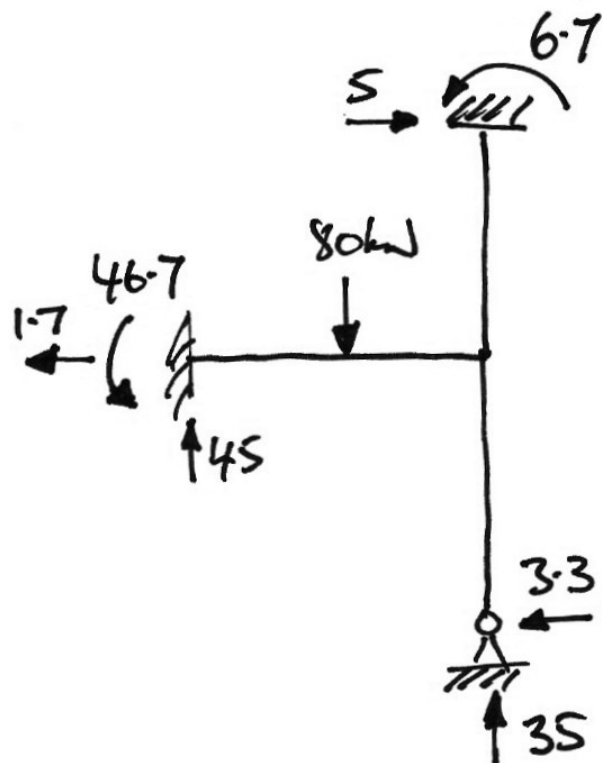
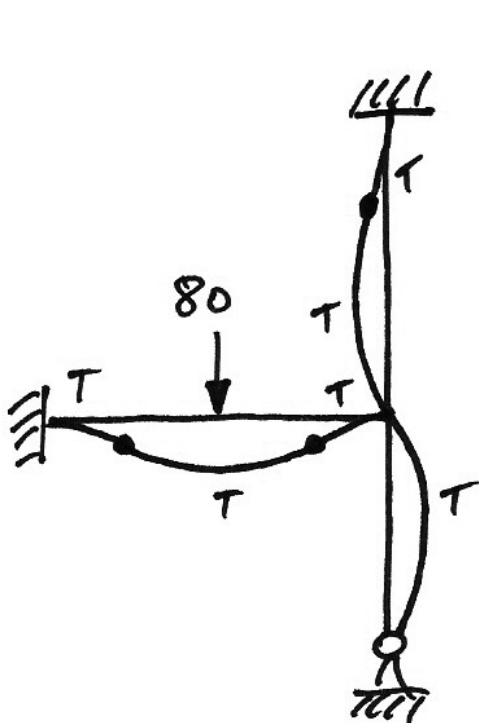
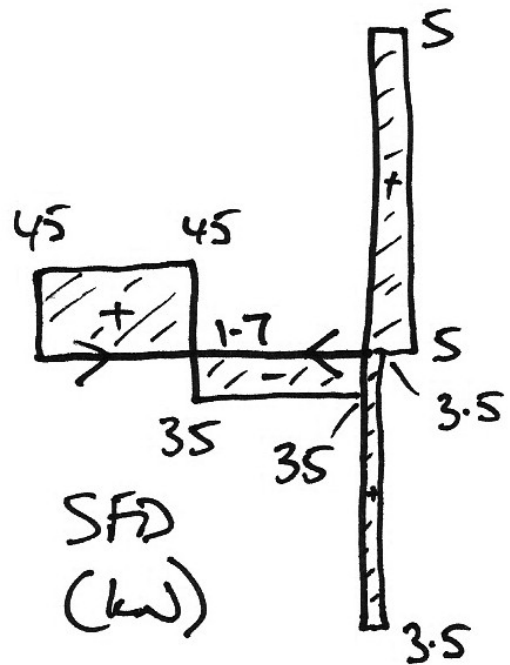
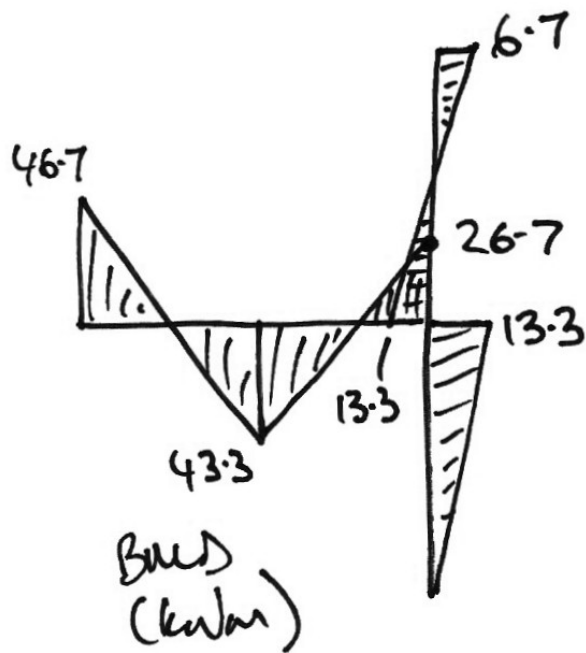

#### 4.4 Example 8: Frame with Cantilever

##### Problem

Analyse the following prismatic frame for all load effects:

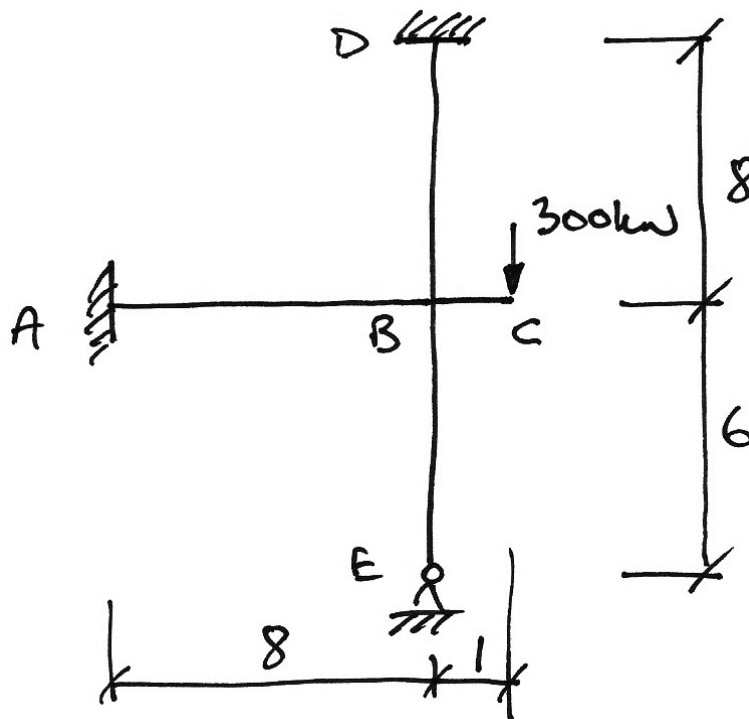

##### Solution

1. Stiffnesses:

- $AB$ :  $k_{BA} = \left(\frac{EI}{L}\right)_{AB} = \frac{1}{8}$
- $BC$ : Member  $BC$  has no stiffness since it is a cantilever;
- $BD$ :  $k_{BD} = \left(\frac{EI}{L}\right)_{BD} = \frac{1}{8}$
- $BE$ :  $k'_{BE} = \frac{3}{4} \left(\frac{EI}{L}\right)_{BE} = \frac{3}{4} \cdot \frac{1}{6} = \frac{1}{8}$

2. Distribution Factors:

- Joint B:

$$\sum k = \frac{1}{8} + \frac{1}{8} + \frac{1}{8} = \frac{3}{8}$$

$$\left. \begin{aligned} DF_{BA} &= \frac{k_{BA}}{\sum k} = \frac{1/8}{3/8} = 0.33 \\ DF_{BD} &= \frac{k_{BD}}{\sum k} = \frac{1/8}{3/8} = 0.33 \\ DF_{BE} &= \frac{k_{BE}}{\sum k} = \frac{1/8}{3/8} = 0.33 \end{aligned} \right\} \sum DFs = 1$$

3. Fixed-End Moments:

- Span BC:

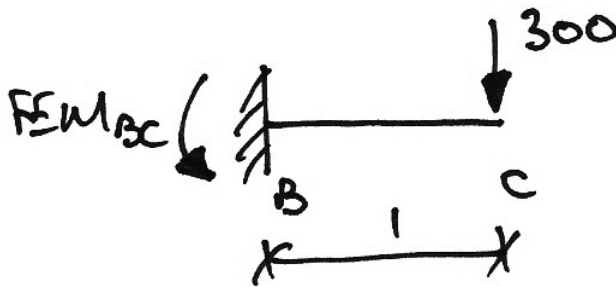

$$\begin{aligned} FEM_{BC} &= +PL = +300 \cdot 1 \\ &= +300 \text{ kNm} \end{aligned}$$

4. Moment Distribution Table:

Joint	A		B			D	E
Member	AB	BA	BC	BE	BD	DB	EB
DF	0	0.33	0	0.33	0.33	0	0
FEM			+300.0				
Dist.		-100.0		-100.0	-100.0		
C.O.	-50.0					-50.0	
Final	-50.0	-100.0	+300.0	-100.0	-100.0	-50.0	0

Using the signs, the results of the moment distribution are summed up in the following diagram:

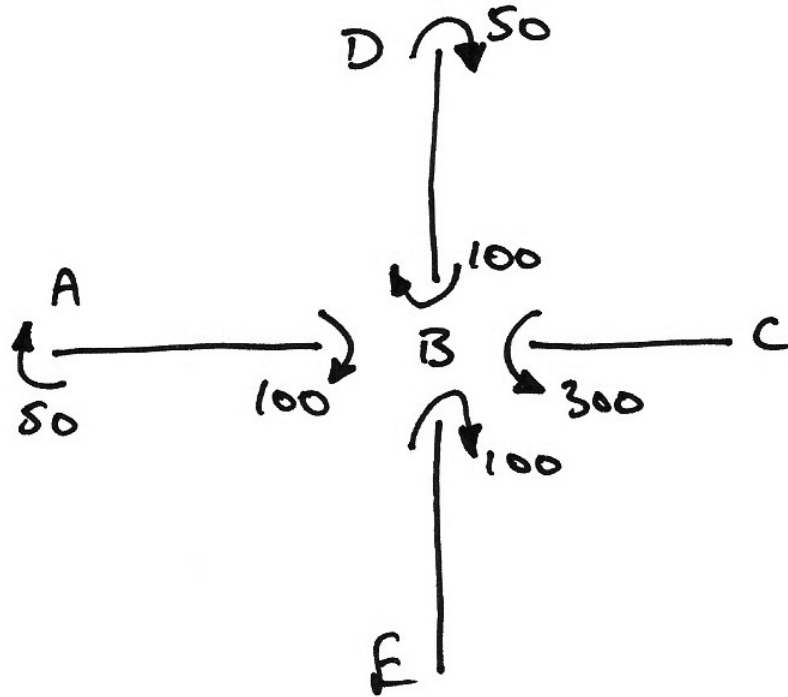

Looking at joint B, we see that it is in moment equilibrium as expected:

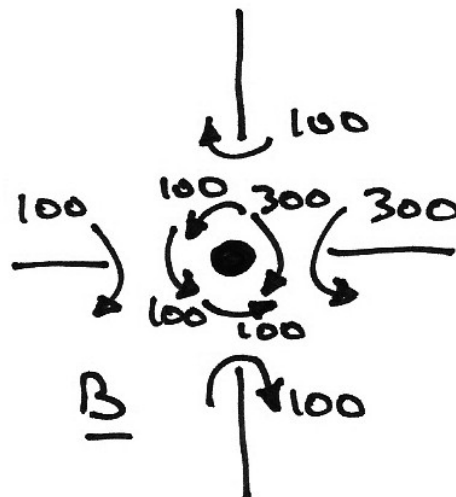

**Final Solution**

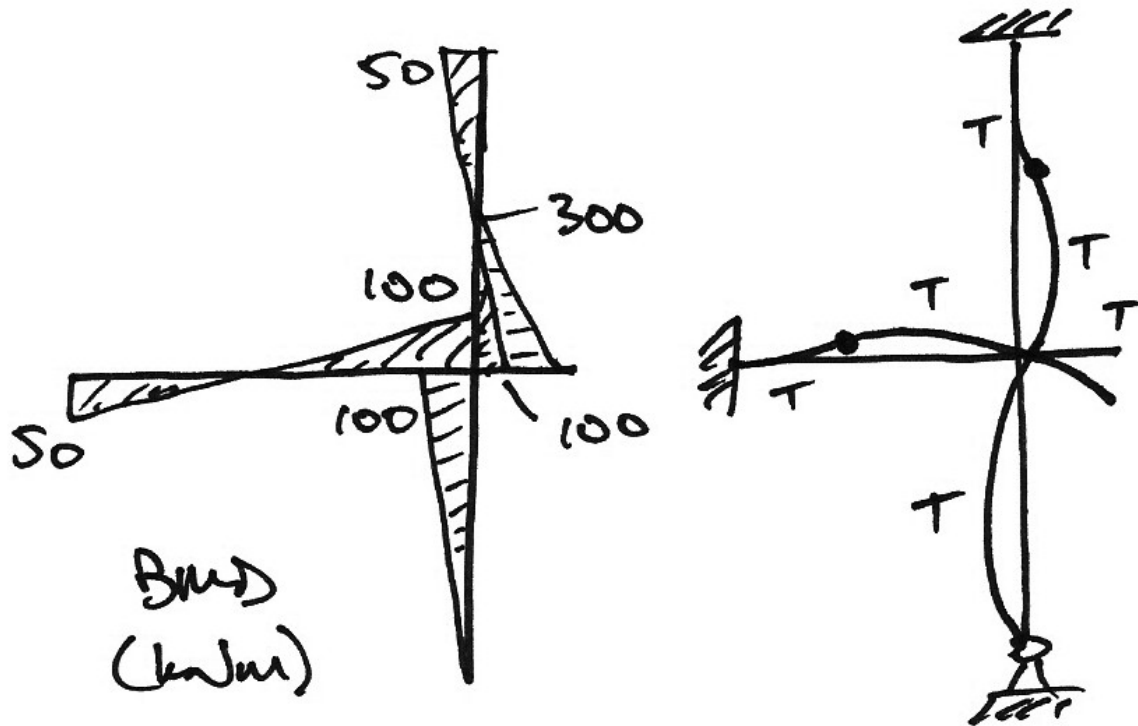

**Exercise:**

Using a similar approach to the previous examples, find the reactions and shear force diagram.

Ans.:

$$M_A = -50.0 \text{ kNm} \quad V_A = 18.75 \text{ kN} \downarrow \quad H_A = 2.05 \text{ kN} \rightarrow$$

$$M_C = -50.0 \text{ kNm} \quad V_C = 0 \text{ kN} \quad H_C = 18.75 \text{ kN} \leftarrow$$

$$V_D = 318.75 \text{ kN} \quad H_D = 16.7 \text{ kN} \leftarrow$$

**4.5 Problems**

Using moment distribution, determine the bending moment diagram, shear force diagram, reactions and deflected shape diagram for the following non-sway frames. Consider them prismatic unless  $EI$  values are given. The reactions and pertinent results of the moment distribution are given.

<p>1.</p>		$V_A = 137 \text{ kN} \downarrow$ $H_A = 13 \text{ kN} \leftarrow$ $M_C = 48 \text{ kNm}$ $V_C = 0 \text{ kN}$ $H_C = 48 \text{ kN} \rightarrow$ $V_D = 337 \text{ kN} \uparrow$ $H_D = 35 \text{ kN} \leftarrow$  $M_{BA} = 52 \text{ kNm}$ $M_{BC} = 96 \text{ kNm}$ $M_{BD} = 148 \text{ kNm}$
<p>2.</p>		$V_A = 200.5 \text{ kN} \uparrow$ $H_A = 120.7 \text{ kN} \leftarrow$ $M_A = 113.3 \text{ kNm}$ $M_C = -23.3 \text{ kNm}$ $V_C = 47.5 \text{ kN} \uparrow$ $H_C = 216.7 \text{ kN} \leftarrow$  $M_B = 73.3 \text{ kNm}$



<p>3.</p>		$V_A = 34.9 \text{ kN } \uparrow$ $H_A = 8.3 \text{ kN } \rightarrow$ $M_A = -16.6 \text{ kNm}$ $M_D = -33.6 \text{ kNm}$ $V_D = 54.6 \text{ kN } \uparrow$ $H_D = 6.8 \text{ kN } \leftarrow$ $V_E = 110.6 \text{ kN } \uparrow$ $H_E = 1.5 \text{ kN } \leftarrow$ $M_B = 33.3 \text{ kNm}$ $M_{CB} = 64.1 \text{ kNm}$ $M_{CD} = 55.2 \text{ kNm}$ $M_{CE} = 8.9 \text{ kNm}$
-----------	--	---

The following problems are relevant to previous exam questions, the year of which is given. The solutions to these problems are required as the first step in the solutions to the exam questions. We shall see why this is so when we study sway frames.

<p>4. Summer 1998</p>		$V_A = 50.0 \text{ kN } \uparrow$ $H_A = 20.0 \text{ kN } \rightarrow$ $H_C = 20.0 \text{ kN } \leftarrow$ $M_D = 0 \text{ kNm}$ $V_D = 30.0 \text{ kN } \uparrow$ $H_D = 0 \text{ kN}$ $M_B = 120.0 \text{ kNm}$
-----------------------	--	--

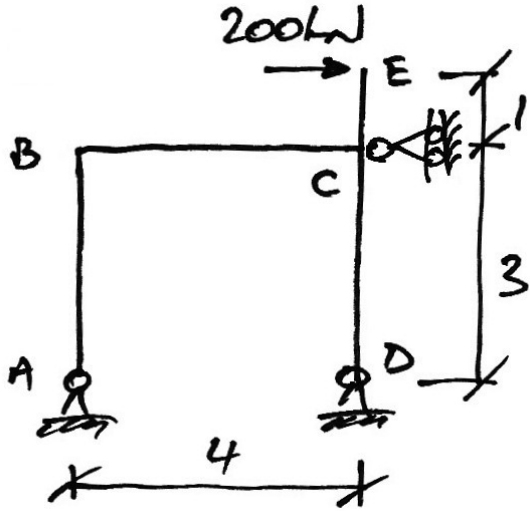
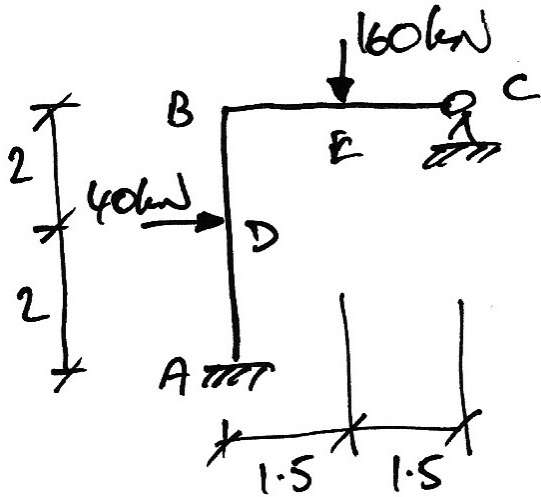
<p>5.</p>	<p>Summer 2000</p> 	<p> <math>V_A = 30.0 \text{ kN} \downarrow</math>  <math>H_A = 8.9 \text{ kN} \leftarrow</math>  <math>H_C = 226.7 \text{ kN} \leftarrow</math>  <math>V_D = 30.0 \text{ kN} \uparrow</math>  <math>H_D = 35.6 \text{ kN} \rightarrow</math> </p> <p> <math>M_B = 26.7 \text{ kNm}</math>  <math>M_{CB} = 93.3 \text{ kNm}</math>  <math>M_{CD} = 106.7 \text{ kNm}</math> </p>
<p>6.</p>	<p>Summer 2001</p> 	<p> <math>M_A = +2.5 \text{ kNm}</math>  <math>V_A = 98.33 \text{ kN} \uparrow</math>  <math>H_A = 6.9 \text{ kN} \leftarrow</math>  <math>V_C = 61.7 \text{ kN} \uparrow</math>  <math>H_C = 33.1 \text{ kN} \leftarrow</math> </p> <p> <math>M_B = 55 \text{ kNm}</math> </p>

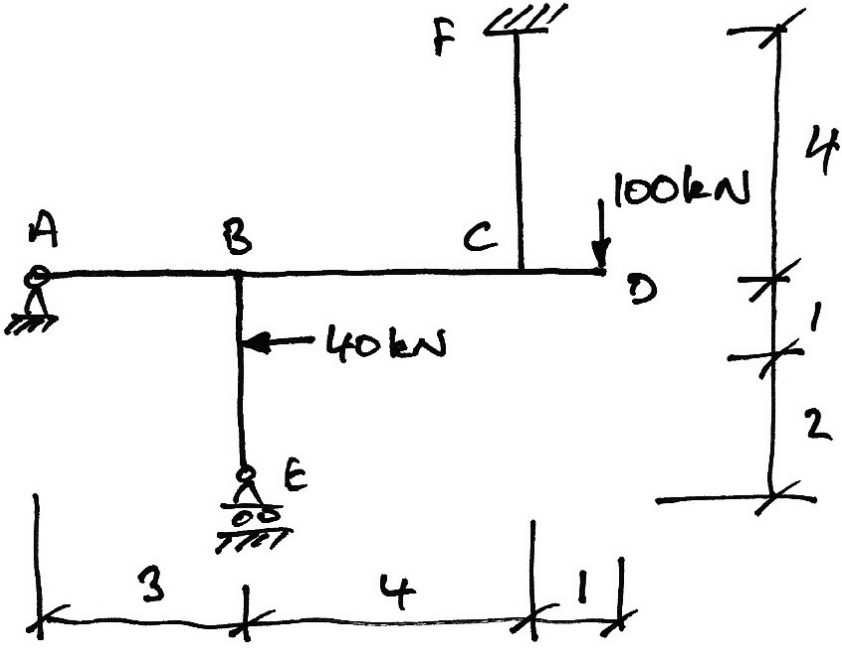
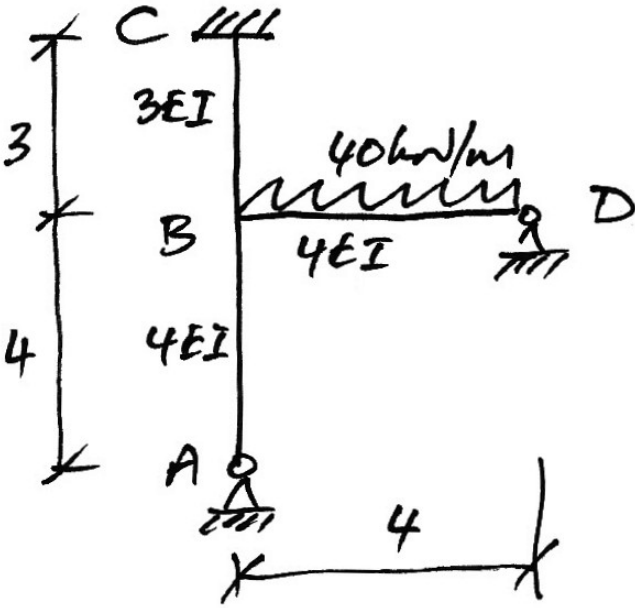
<p>7.</p>	<p>Summer 2005</p> 	<p> <math>V_A = 2.7 \text{ kN} \downarrow</math>  <math>H_A = 58.0 \text{ kN} \rightarrow</math>  <math>V_E = 18.3 \text{ kN} \downarrow</math>  <math>M_F = -24.0 \text{ kNm}</math>  <math>V_F = 121.0 \text{ kN} \uparrow</math>  <math>H_F = 18.0 \text{ kN} \leftarrow</math>    <math>M_{BC} = 32.0 \text{ kNm}</math>  <math>M_{CF} = 48.0 \text{ kNm}</math>  <math>M_{CB} = 52.0 \text{ kNm}</math> </p>
<p>8.</p>	<p>Summer 2006</p> 	<p> <math>V_A = 40.3 \text{ kN} \uparrow</math>  <math>H_A = 6.0 \text{ kN} \rightarrow</math>  <math>M_C = +16.0 \text{ kNm}</math>  <math>V_C = 0 \text{ kN}</math>  <math>H_C = 16.0 \text{ kN} \leftarrow</math>  <math>V_D = 66.0 \text{ kN} \uparrow</math>  <math>H_D = 10.0 \text{ kN} \rightarrow</math>    <math>M_{BA} = 24.0 \text{ kNm}</math>  <math>M_{BD} = 56.0 \text{ kNm}</math>  <math>M_{DB} = 32.0 \text{ kNm}</math> </p>

## 5. Sway Frames

### 5.1 Basis of Solution

#### Overall

Previously, in the description of sway and non-sway frames, we identified that there are two sources of moments:

- Those due to the loads on the members, for example:

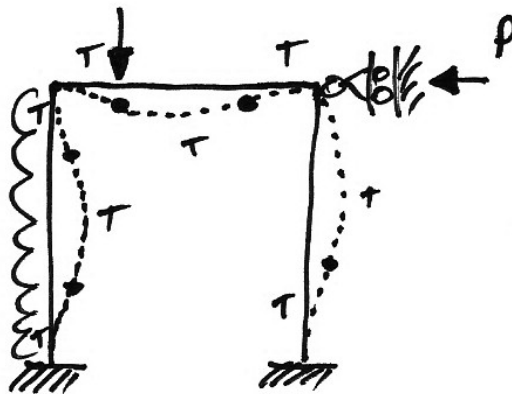

- Those due solely to sway, for example:

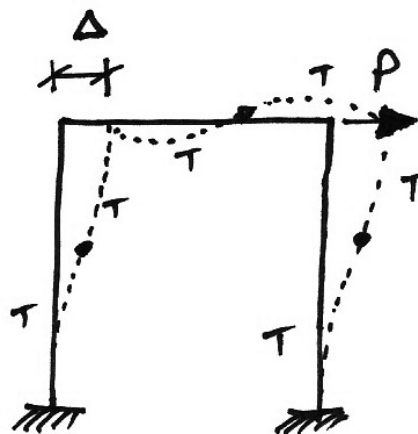

So if we consider any sway frame, such as the following, we can expect to have the above two sources of moments in the frame.

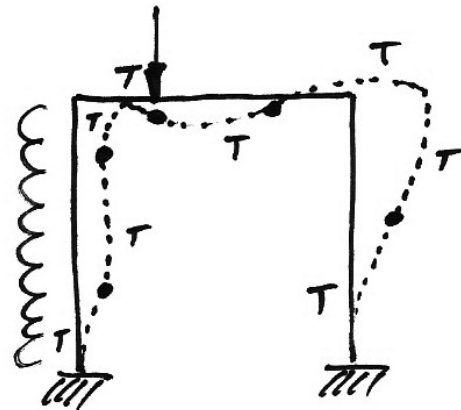

This leads to the use of the Principle of Superposition to solve sway frames:

1. The sway frame is propped to prevent sway;
2. The propping force,  $P$ , is calculated – Stage I analysis;
3. The propping force *alone* is applied to the frame in the opposite direction to calculate the sway moments – the Stage II analysis;
4. The final solution is the superposition of the Stage I and Stage II analyses.

These steps are illustrated for the above frame as:

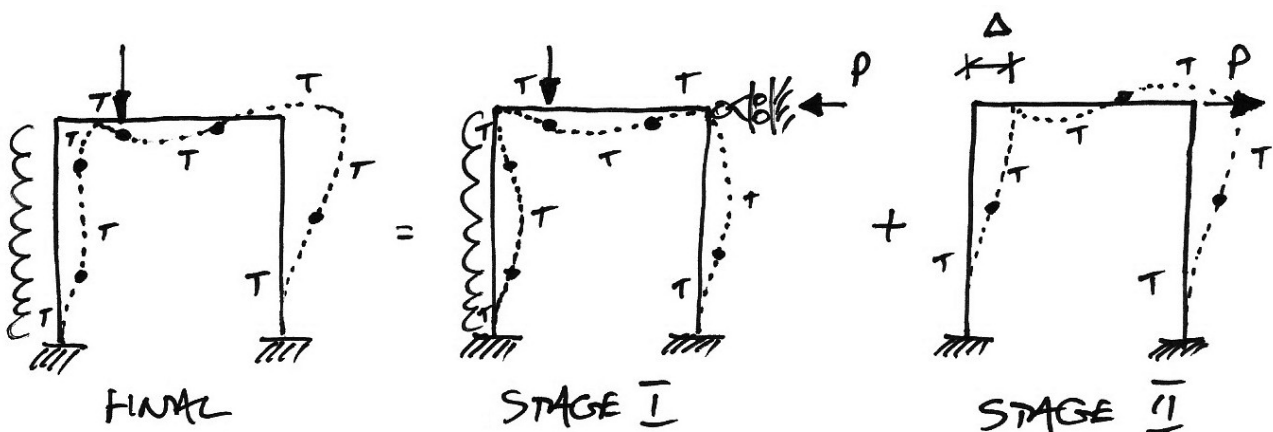

The Stage I analysis is simply that of a non-sway frame, covered previously. The goal of the Stage I analysis is to determine the Stage I BMD and the propping force (or reaction).

### Stage II Analysis

The Stage II analysis proceeds a little differently to usual moment distribution, as follows.

If we examine again Stage II of the sample frame, we see that the prop force,  $P$ , causes an unknown amount of sway,  $\Delta$ . However, we also know that the moments from the lateral movement of joints depends on the amount of movement (or sway):

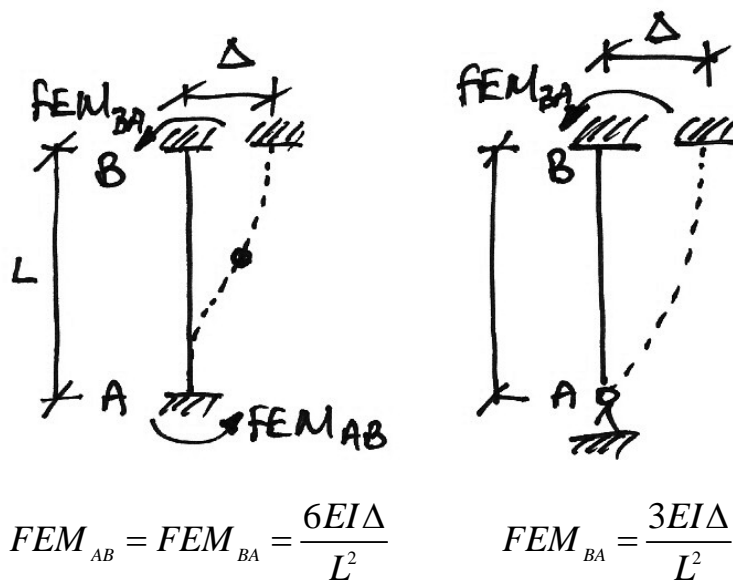

Since we don't know the amount of sway,  $\Delta$ , that occurs, we cannot find the FEMs.

The Stage II solution procedure is:

1. We assume a sway, (called the arbitrary sway,  $\Delta^*$ ); calculate the FEMs this sway causes (the arbitrary FEMs). Then, using moment distribution we find the moments corresponding to that sway (called the arbitrary moments,  $M_{II}^*$ ). This is the Stage II analysis.
2. From this analysis, we solve to find the value of the propping force,  $P^*$ , that would cause the arbitrary sway assumed.
3. Since this force  $P^*$  is linearly related to its moments,  $M_{II}^*$ , we can find the moments that our *known* prop force,  $P$ , causes,  $M_{II}$ , by just scaling (which is a use of the Principle of Superposition):

$$\frac{P}{P^*} = \frac{M_{II}}{M_{II}^*}$$

Introducing the *sway factor*,  $\alpha$ , which is given by the ratio:

$$\alpha = \frac{P}{P^*}$$

We then have for the actual moments and sway respectively:

$$M_{II} = \alpha M_{II}^*$$

$$\Delta = \alpha \Delta^*$$

Diagrammatically the first two steps are:

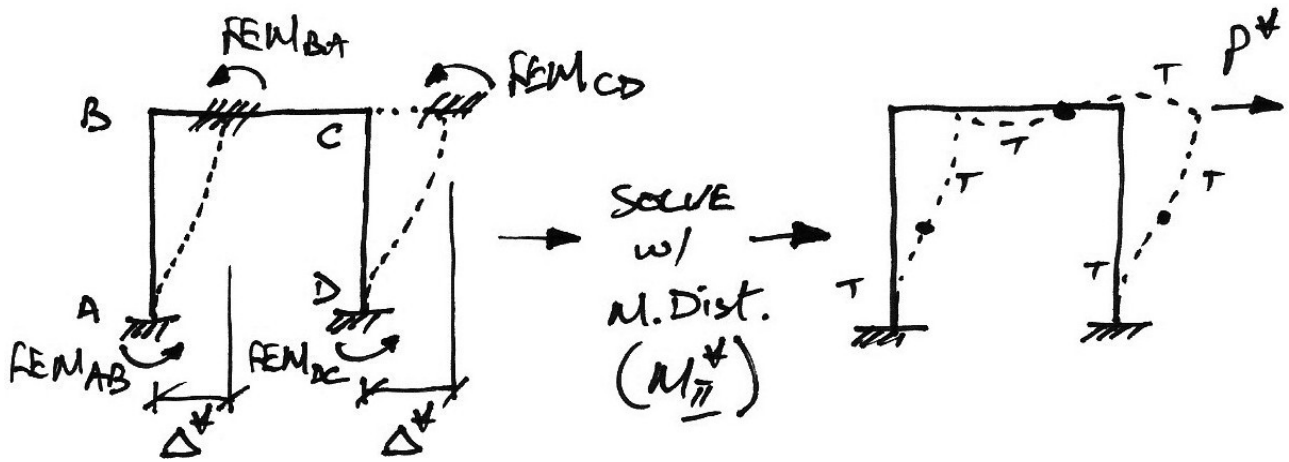



### 5.2 Example 9: Illustrative Sway Frame

#### Problem

Analyse the following prismatic frame for the bending moment diagram:

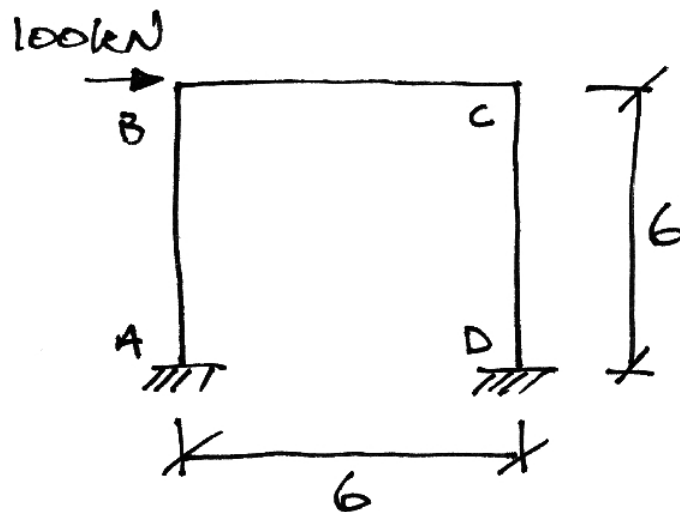

#### Solution

This is a sway frame and thus a two-stage analysis is required:

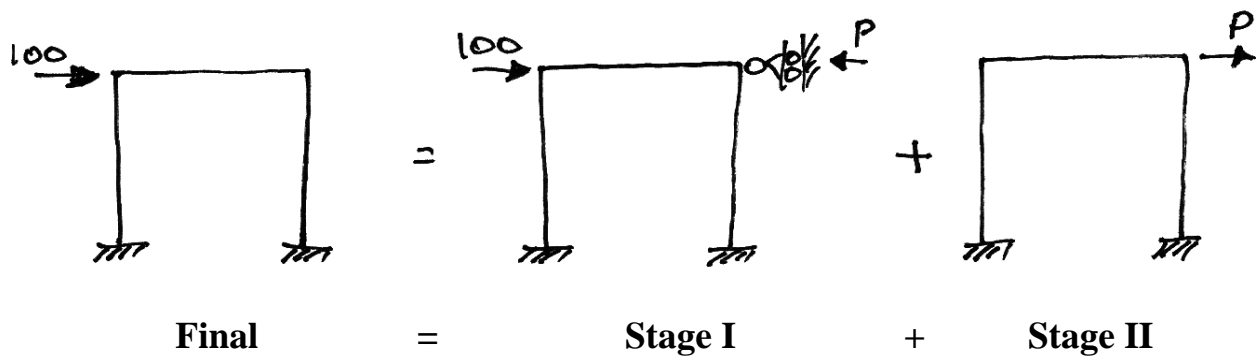

However, since we have no inter-nodal loading (loading between joints), and since we are neglecting axial deformation, Stage I has no moments. Therefore the original frame is already just a Stage II analysis – compare the Final and Stage II frames: they are mirror images.

Next we allow the frame to sway, whilst keeping the joints locked against rotation:

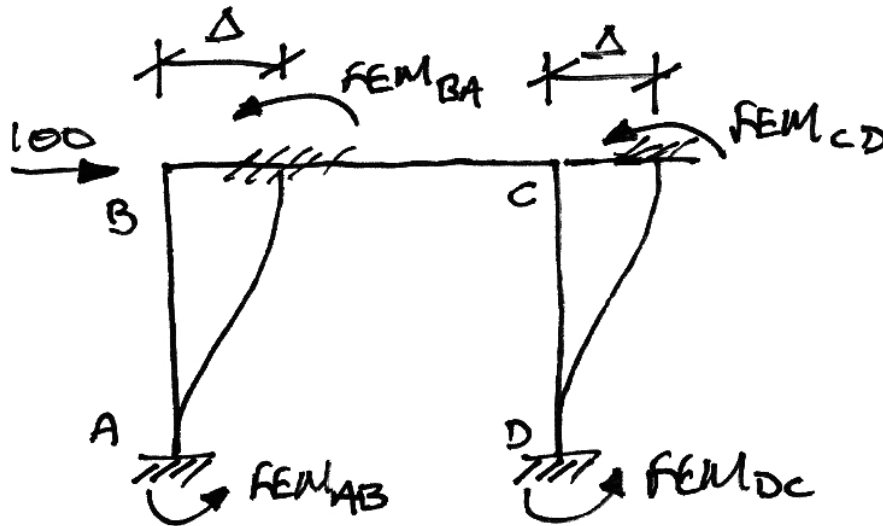

From this figure, it is clear that the FEMs are:

$$FEM_{BA} = FEM_{AB} = \frac{6EI}{L^2} \Delta$$

$$FEM_{DC} = FEM_{CD} = \frac{6EI}{L^2} \Delta$$

Since we don't know how much it sways, we cannot determine the FEMs. Therefore we choose to let it sway an arbitrary amount,  $\Delta^*$ , and then find the force  $P^*$  that causes this amount of sway. Let's take the arbitrary sway to be:

$$\Delta^* = \frac{600}{EI}$$

And so the arbitrary FEMs become:

$$FEM_{BA} = FEM_{AB} = \frac{6EI}{6^2} \left( \frac{600}{EI} \right) = 100 \text{ kNm}$$

$$FEM_{DC} = FEM_{CD} = \frac{6EI}{6^2} \left( \frac{600}{EI} \right) = 100 \text{ kNm}$$

We could have avoided the step of choosing an intermediate arbitrary sway by simply choosing arbitrary FEMs, as we will do in future.

With the FEMs now known, we must carry out a moment distribution to find the force,  $P^*$ , associated with the arbitrary FEMs (or sway).

1. Stiffnesses:

- $AB$ :  $k_{AB} = \left( \frac{EI}{L} \right)_{AB} = \frac{1}{6}$

- $BC$ :  $k_{BC} = \left( \frac{EI}{L} \right)_{BC} = \frac{1}{6}$

- $CD$ :  $k_{CD} = \left( \frac{EI}{L} \right)_{CD} = \frac{1}{6}$

2. Distribution Factors:

- Joint  $B$ :

$$\sum k = \frac{1}{6} + \frac{1}{6} = \frac{2}{6}$$

$$\left. \begin{aligned} DF_{BA} &= \frac{k_{BA}}{\sum k} = \frac{1/6}{2/6} = 0.5 \\ DF_{BC} &= \frac{k_{BD}}{\sum k} = \frac{1/6}{2/6} = 0.5 \end{aligned} \right\} \sum DFs = 1$$

- Joint  $C$ : is the same as Joint  $B$ .

3. Fixed-End Moments:

For the FEMs we simply take the arbitrary FEMs already chosen.

4. Moment Distribution Table:

Joint	A	B		C		D
Member	AB	BA	BC	CB	CD	DC
DF	0	0.5	0.5	0.5	0.5	0
FEM	+100	+100			+100	+100
Dist.		-50	-50	-50	-50	
C.O.	-25		-25	-25		-25
Dist.		+12.5	+12.5	+12.5	+12.5	
C.O.	+6.3		+6.3	+6.3		+6.3
Dist.		-3.2	-3.2	-3.2	-3.2	
C.O.	-1.6		-1.6	-1.6		-1.6
Dist.		+0.8	+0.8	+0.8	+0.8	
Final	+79.7	+60.1	-60.2	-60.2	+60.1	+79.7

Thus approximately we have moments of 80 and 60 kNm at the joints. Notice also that the result is symmetrical, as it should be.

5. Calculate End Shears and Forces

Span *AB*:

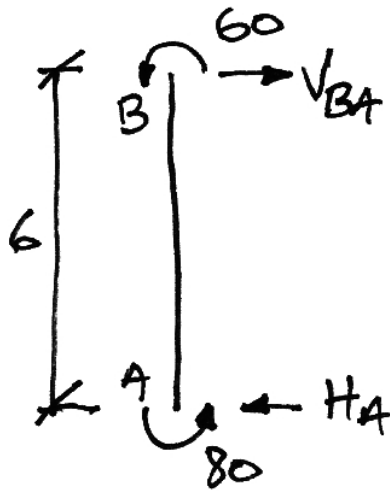

$$\begin{aligned} \sum M \text{ about } A &= 0 \\ \therefore 80 + 60 - 6V_{BA} &= 0 \\ \therefore V_{BA} &= 23.3 \text{ kN} \rightarrow \end{aligned}$$

$$\begin{aligned} \sum F_x &= 0 \\ \therefore H_A &= +23.3 \text{ kN} \leftarrow \end{aligned}$$

Span *BC*:

This is the same as *AB*.

Our solution thus far is:

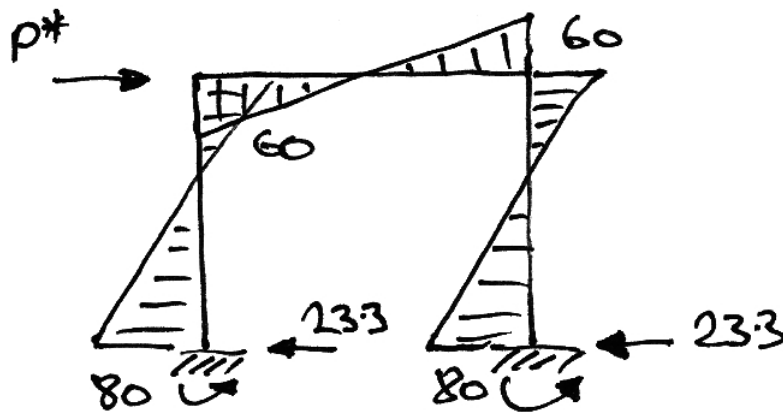

Thus the total horizontal reaction at *A* and *D* is  $23.3 + 23.3 = 46.6$  kN. This therefore is the force causing the arbitrary moments and sway:

$$P^* = 46.6 \text{ kN}$$

Returning to the original problem, the actual force applied is 100 kN, not 46.6 kN. Thus, by superposition, we obtain the solution to our original problem if we ‘scale up’ the current solution by the appropriate amount, the sway factor:

$$\alpha = \frac{P}{P^*} = \frac{100}{46.6} = 2.15$$

So if we multiply our current solution by 2.15 we will obtain the solution to our actual problem:

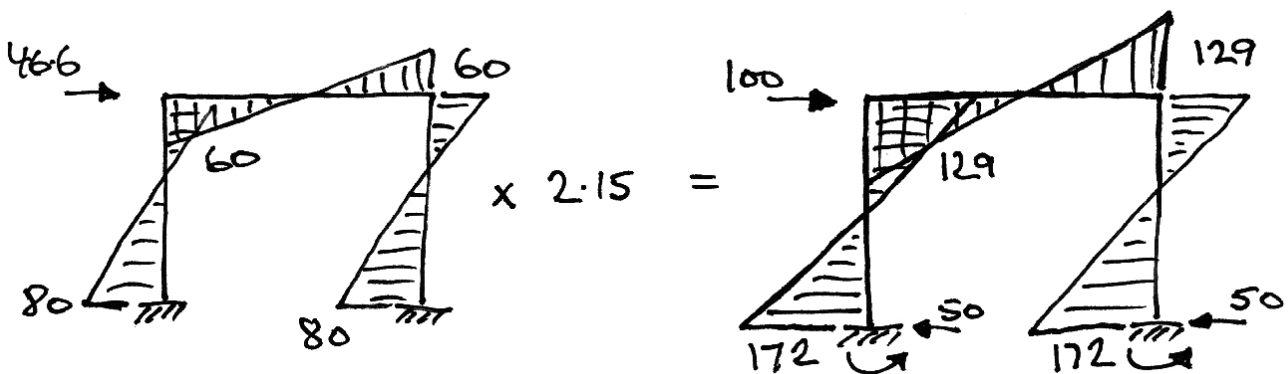

And this then is the final solution.

### Arbitrary Sway and Arbitrary Moments

As we have just seen, when we choose an arbitrary sway,  $\Delta^*$ , we could really choose handy ‘round’ FEMs instead. For example, taking  $\Delta^* = 100/EI$  for the previous frame gives:

$$\begin{aligned} FEM_{AB} &= FEM_{BA} = FEM_{CD} = FEM_{DC} \\ &= \frac{6EI}{6^2} \cdot \frac{100}{EI} \\ &= 16.67 \text{ kNm} \end{aligned}$$

This number is not so ‘round’. So instead we usually just choose arbitrary moments, such as 100 kNm, as we did in the example:

$$\begin{aligned} FEM_{AB} &= FEM_{BA} = FEM_{CD} = FEM_{DC} \\ &= 100 \text{ kNm} \end{aligned}$$

And this is much easier to do. But do remember that in choosing an arbitrary moment, we are really just choosing an arbitrary sway. As we saw, the arbitrary sway associated with the 100 kNm arbitrary moment is:

$$\begin{aligned} 100 &= \frac{6EI}{6^2} \cdot \Delta^* \\ \Delta^* &= \frac{600}{EI} \end{aligned}$$

We will come back to arbitrary moments later in more detail after all of the preceding ideas have been explained by example.

### 5.3 Example 10: Simple Sway Frame

#### Problem

Analyse the following prismatic frame for all load effects:

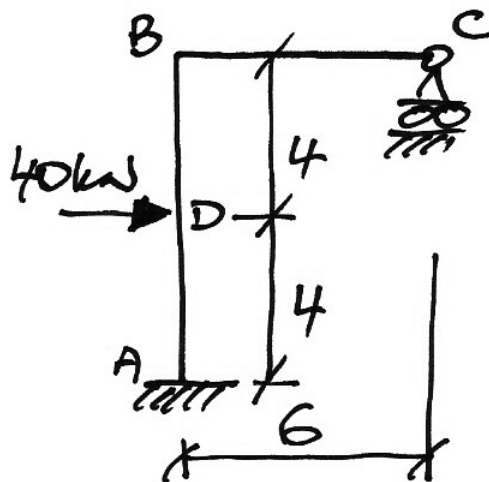

#### Solution

Firstly we recognize that this is a sway frame and that a two-stage analysis is thus required. We choose to prop the frame at C to prevent sway, and use the following two-stage analysis:

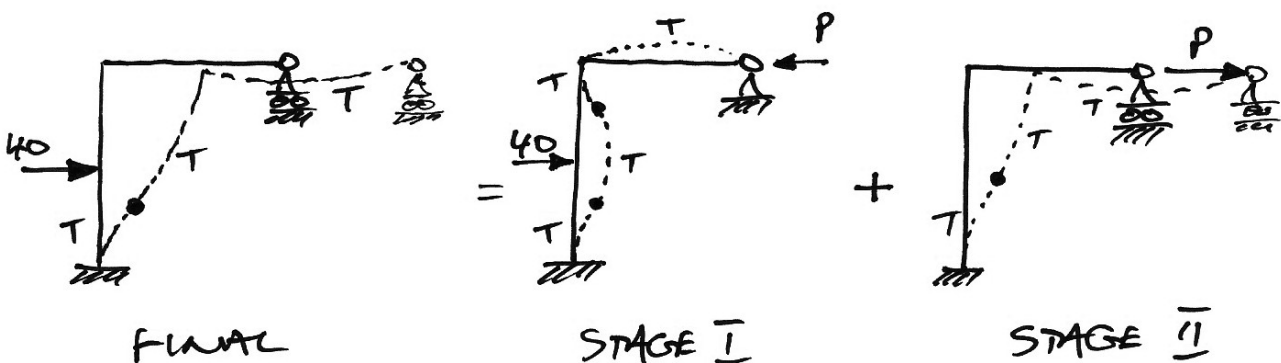



### Stage I Analysis

We proceed as usual for a non-sway frame:

#### 1. Stiffnesses:

- $AB$ :  $k_{BA} = \left(\frac{EI}{L}\right)_{AB} = \frac{1}{8}$
- $BC$ :  $k'_{BC} = \frac{3}{4} \left(\frac{EI}{L}\right)_{BC} = \frac{3}{4} \cdot \frac{1}{6} = \frac{1}{8}$

#### 2. Distribution Factors:

- Joint  $B$ :

$$\sum k = \frac{1}{8} + \frac{1}{8} = \frac{2}{8}$$

$$\left. \begin{aligned} DF_{BA} &= \frac{k_{BA}}{\sum k} = \frac{1/8}{2/8} = 0.5 \\ DF_{BC} &= \frac{k_{BD}}{\sum k} = \frac{1/8}{2/8} = 0.5 \end{aligned} \right\} \sum DFs = 1$$

#### 3. Fixed-End Moments:

- Span  $AB$ :

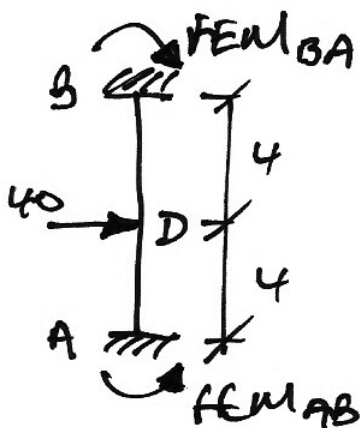

$$FEM_{BA} = -\frac{PL}{8} = -\frac{40 \cdot 8}{8} = -40 \text{ kNm}$$

$$FEM_{AB} = +\frac{PL}{8} = +40 \text{ kNm}$$

4. Moment Distribution Table:

Joint	A	B		C
Member	AB	BA	BC	CB
DF	1	0.5	0.5	0
FEM	+40	-40		
Dist.		+20	+20	
C.O.	+10			
Final	+50	-20	+20	

5. Calculate End Shears and Forces

Span AB:



$$\begin{aligned} \sum M \text{ about } A &= 0 \\ \therefore 8V_{BA} + 50 - 20 - 40 \cdot 4 &= 0 \\ \therefore V_{BA} &= +16.25 \text{ kN } \leftarrow \end{aligned}$$

$$\begin{aligned} \sum F_x &= 0 \\ \therefore H_A + V_{BA} - 40 &= 0 \\ \therefore H_A &= +23.75 \text{ kN } \leftarrow \end{aligned}$$

Span BC:

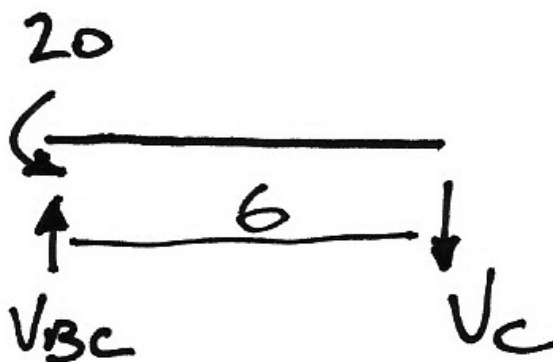

$$\begin{aligned} \sum M \text{ about } B &= 0 \\ \therefore 20 - 6V_C &= 0 \\ \therefore V_C &= +3.33 \text{ kN } \downarrow \end{aligned}$$

$$\begin{aligned} \sum F_y &= 0 \\ \therefore V_{BC} - V_C &= 0 \\ \therefore V_{BC} &= +3.33 \text{ kN } \uparrow \end{aligned}$$

6. Draw BMD and reactions at a minimum for Stage I. Here we give everything for completeness:

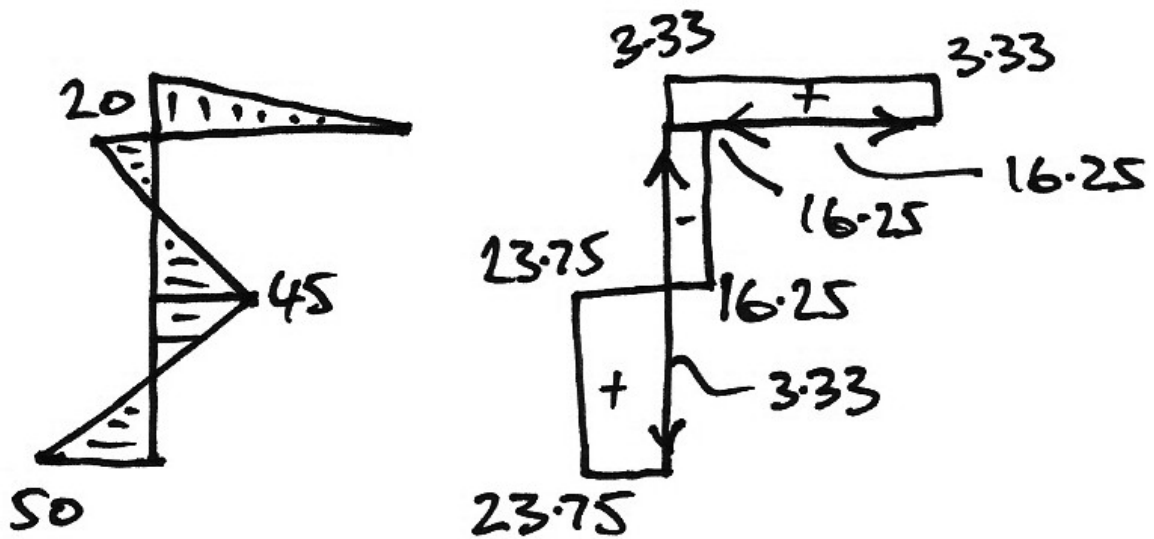
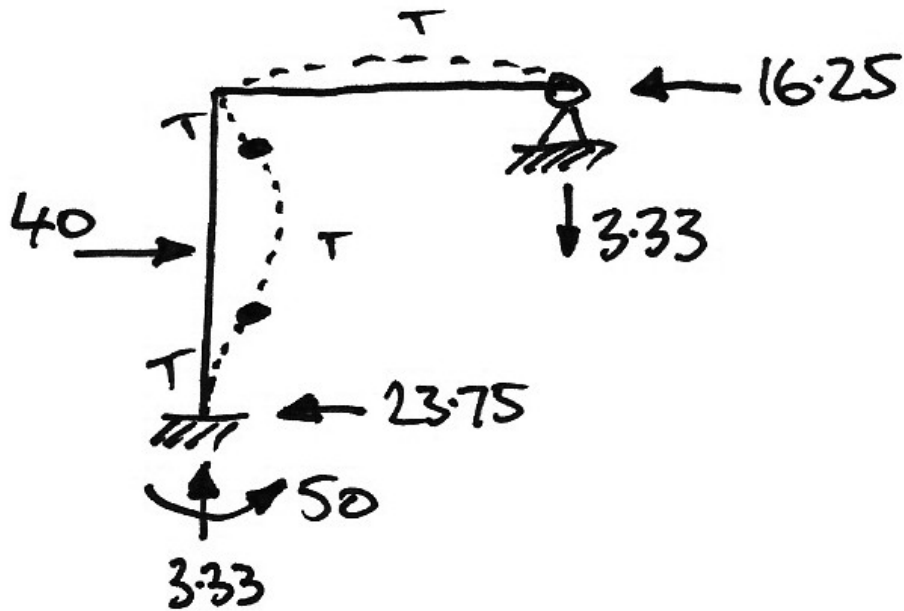

BMD  
(kNm)

SFD / AFD  
(kN)

**Stage II Analysis**

In this stage, showing the joints locked against rotation, we are trying to analyse for the following loading:

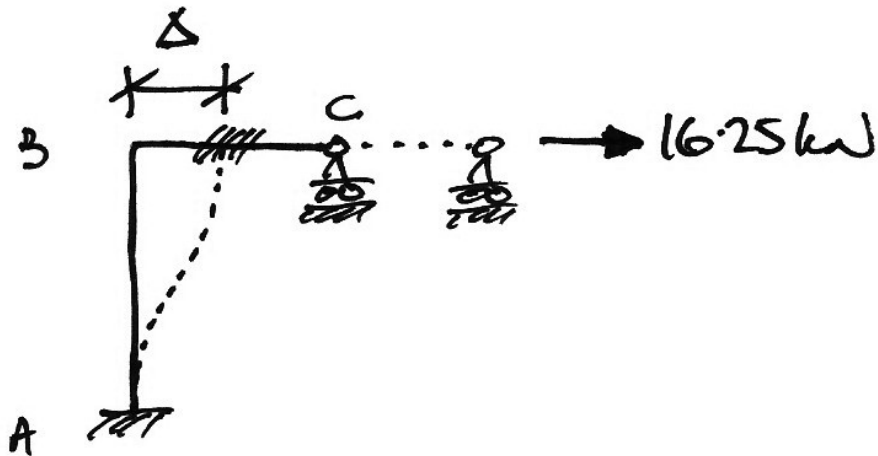

But since we can't figure out what the sway,  $\Delta$ , caused by the actual prop force,  $P$ , is, we must use an arbitrary sway,  $\Delta^*$ , and associated arbitrary FEMs:

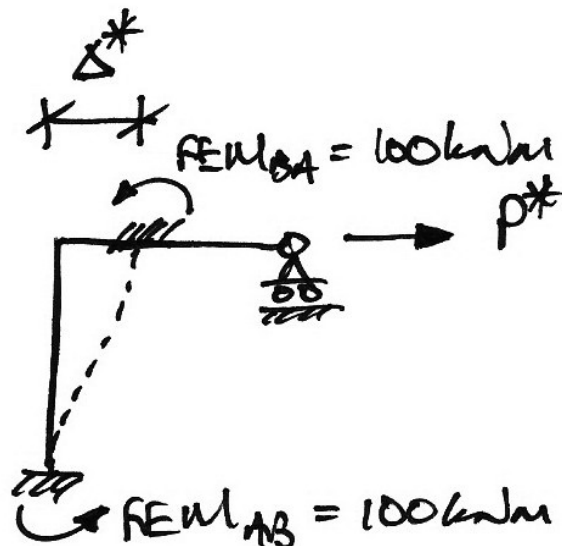

So we are using a value of 100 kNm as our arbitrary FEMs – note that we could have chosen any handy number. Next we carry out a moment distribution of these arbitrary FEMs:

Joint	A	B		C
Member	AB	BA	BC	CB
DF	1	0.5	0.5	0
FEM	+100	+100		
Dist.		-50	-50	
C.O.	-25			
Final	+75	+50	-50	

And we analyse for the reactions:

**Span AB:**

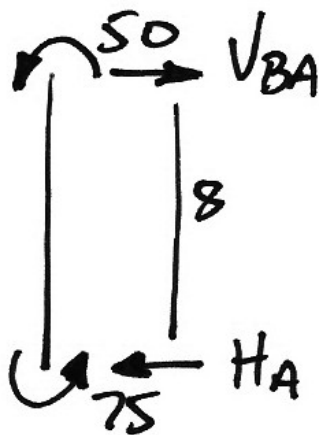

$$\begin{aligned} \sum M \text{ about } A &= 0 \\ \therefore 8V_{BA} - 50 - 75 &= 0 \\ \therefore V_{BA} &= +15.625 \text{ kN } \rightarrow \end{aligned}$$

$$\begin{aligned} \sum F_x &= 0 \\ \therefore H_A + V_{BA} &= 0 \\ \therefore H_A &= +15.625 \text{ kN } \leftarrow \end{aligned}$$

**Span BC:**

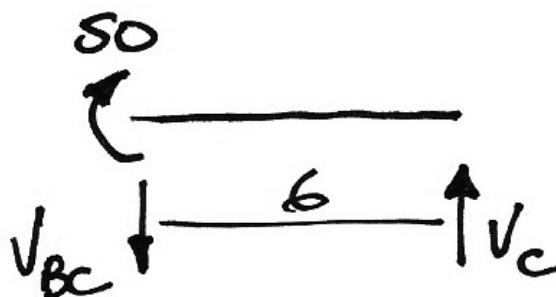

$$\begin{aligned} \sum M \text{ about } B &= 0 \\ \therefore 50 - 6V_C &= 0 \\ \therefore V_C &= +8.33 \text{ kN } \uparrow \end{aligned}$$

$$\begin{aligned} \sum F_y &= 0 \\ \therefore V_{BC} - V_C &= 0 \\ \therefore V_{BC} &= +8.33 \text{ kN } \downarrow \end{aligned}$$

The arbitrary solution is thus:

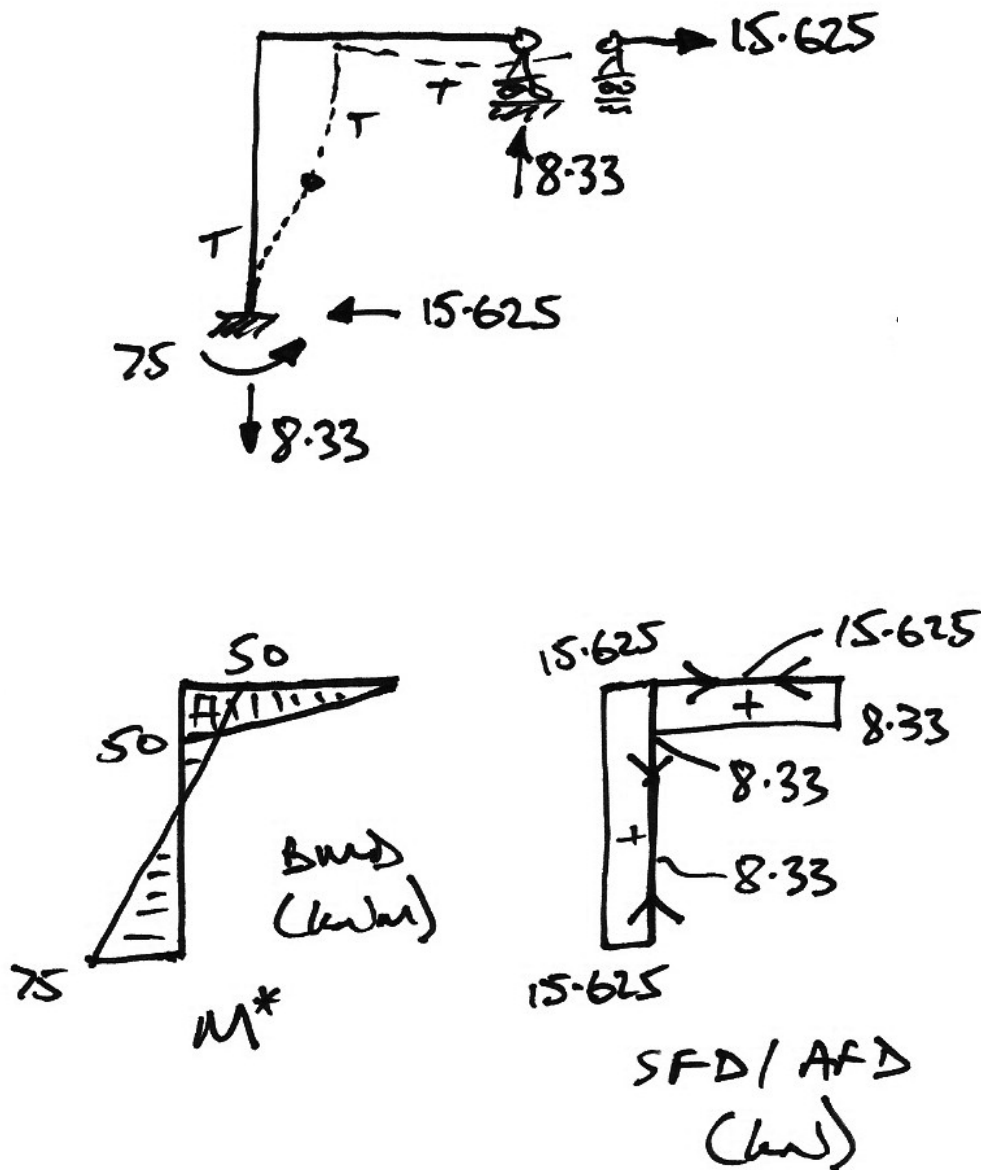

We can see that a force of 15.625 kN causes the arbitrary moments in the BMD above. However, we are interested in the moments that a force of 16.25 kN would cause, and so we scale by the sway factor,  $\alpha$ :

$$\alpha = \frac{P}{P^*} = \frac{16.25}{15.625} = 1.04$$

And so the moments that a force of 16.25 kN causes are thus:

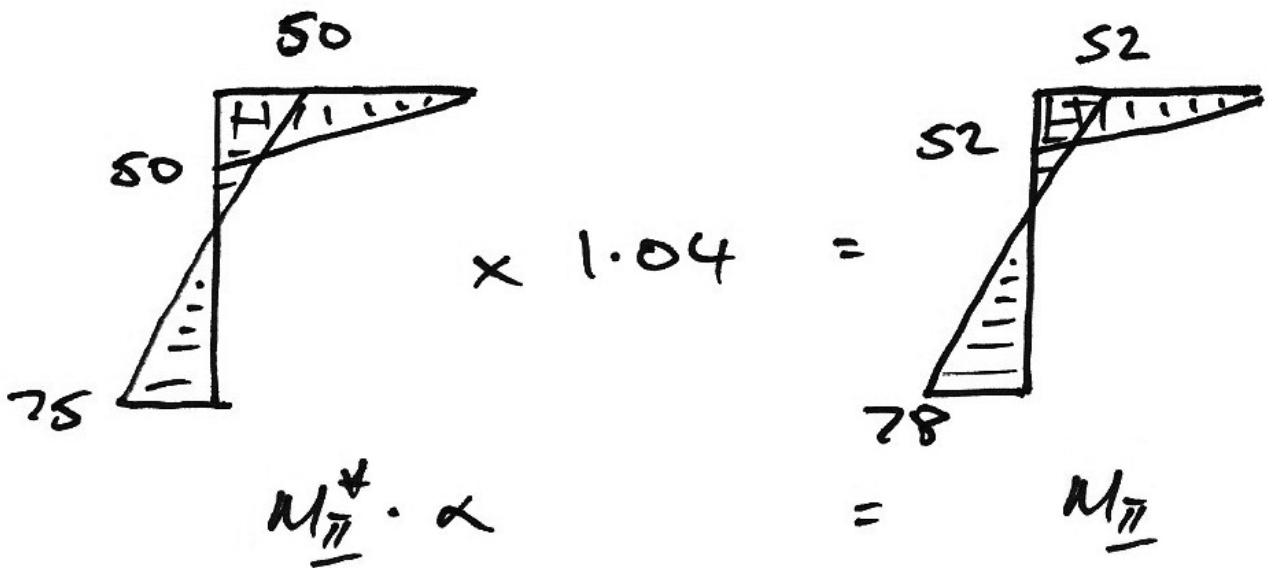

And this is the final Stage II BMD.

**Final Superposition**

To find the total BMD we add the Stage I and Stage II BMDs:

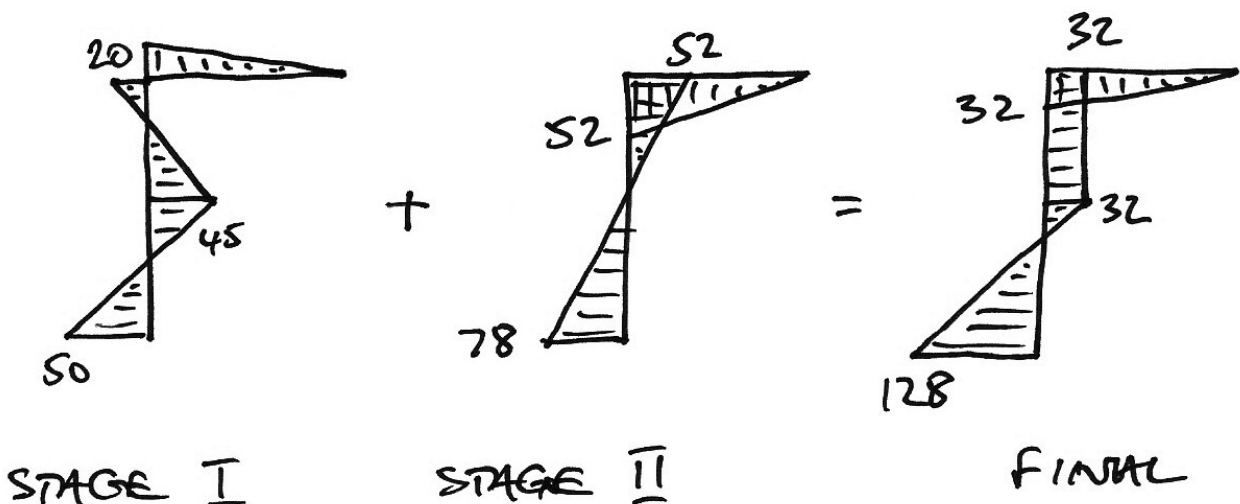

And from the BMD we can calculate the reactions etc. as usual:

Span AB:

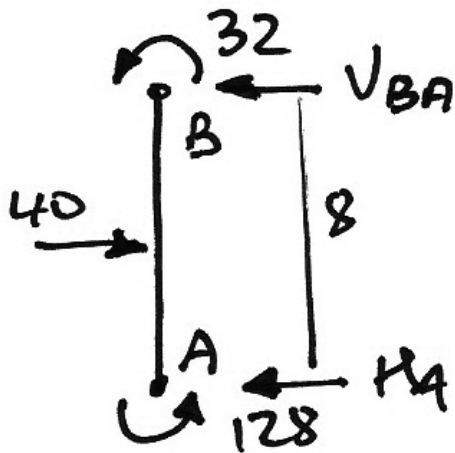

$$\begin{aligned} \sum M \text{ about } A &= 0 \\ \therefore 8V_{BA} + 32 + 128 - 40 \cdot 4 &= 0 \\ \therefore V_{BA} &= 0 \text{ as is expected} \end{aligned}$$

$$\begin{aligned} \sum F_x &= 0 \\ \therefore H_A + V_{BA} - 40 &= 0 \\ \therefore H_A &= +40 \text{ kN } \leftarrow \end{aligned}$$

Span BC:

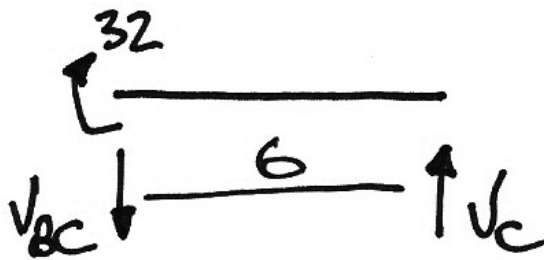

$$\begin{aligned} \sum M \text{ about } B &= 0 \\ \therefore 32 - 6V_C &= 0 \\ \therefore V_C &= +5.33 \text{ kN } \uparrow \end{aligned}$$

$$\begin{aligned} \sum F_y &= 0 \\ \therefore V_{BC} - V_C &= 0 \\ \therefore V_{BC} &= +5.33 \text{ kN } \downarrow \end{aligned}$$

As an aside, it is useful to note that we can calculate the sway also:

$$\begin{aligned} 100 &= \frac{6EI}{8^2} \cdot \Delta^* \\ \Delta^* &= \frac{1066.67}{EI} \end{aligned}$$

And since  $\Delta = \alpha \Delta^*$ , we have:

$$\Delta = 1.04 \times \frac{1066.67}{EI} = \frac{1109.3}{EI}$$



Final Solution

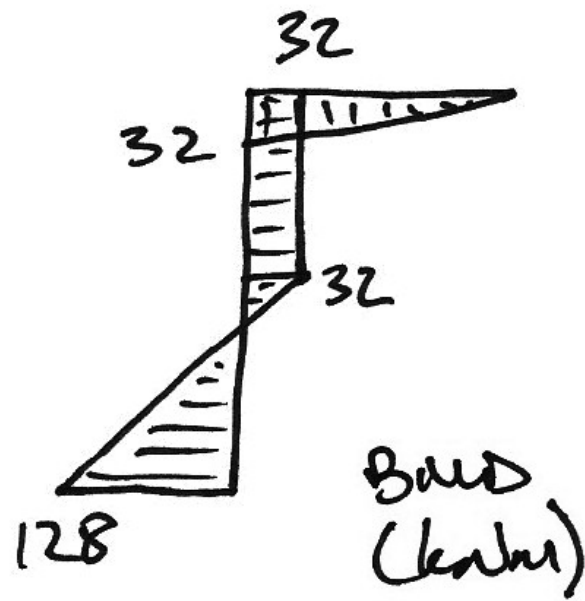
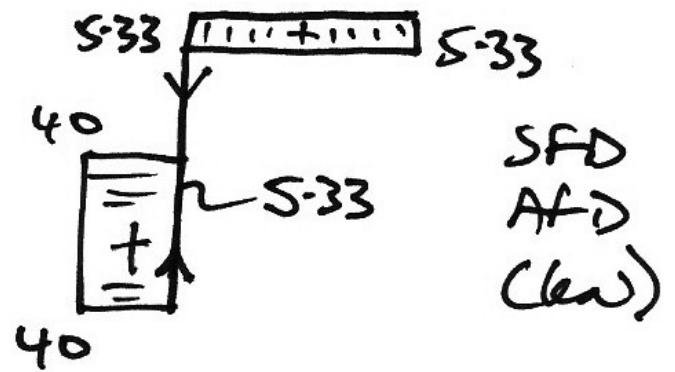
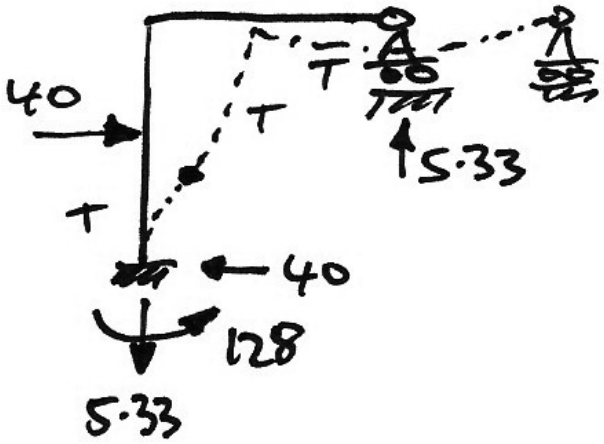

## 5.4 Arbitrary Sway of Rectangular Frames

### Introduction

For simple rectangular frames, such as the previous example, the arbitrary FEMs were straightforward. For example, consider the following structures in which it is simple to determine the arbitrary FEMs:

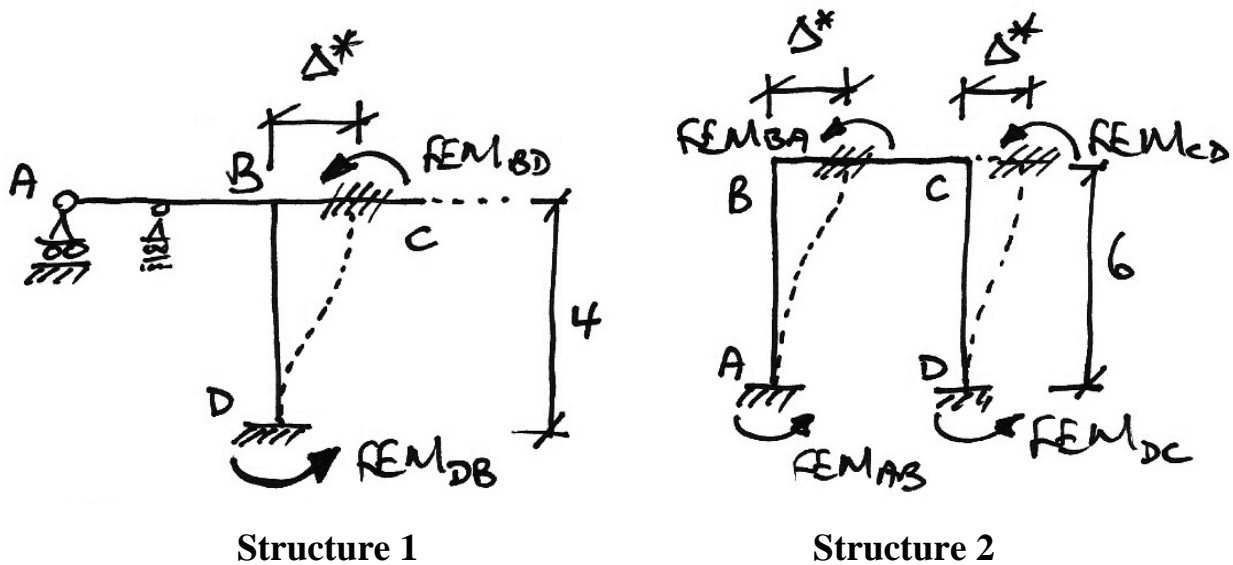

So for Structure 1, we have:

$$FEM_{BD} = FEM_{DB} = \frac{6EI}{L^2} \Delta^* = 100 \text{ kNm say}$$

And for Structure 2:

$$FEM_{BA} = FEM_{AB} = \frac{6EI}{L^2} \Delta^* \text{ and } FEM_{CD} = FEM_{DC} = \frac{6EI}{L^2} \Delta^* = 100 \text{ kNm say.}$$

However, we might have members differing in length, stiffness and/or support-types and we consider these next.

### Differing Support Types

Consider the following frame:

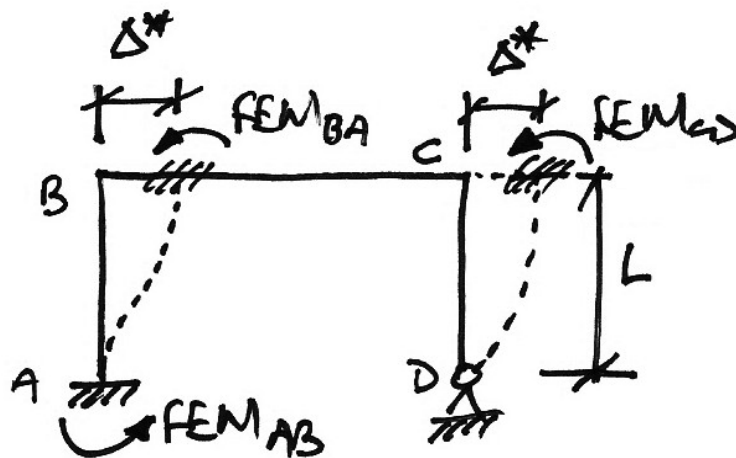

In this case we have:

$$FEM_{AB} = FEM_{BA} = \frac{6EI}{L^2} \Delta^*$$

$$FEM_{CD} = \frac{3EI}{L^2} \Delta^*$$

Since the sway is the same for both sets of FEMs, the arbitrary FEMs must be in the same ratio, that is:

$$\begin{array}{l} FEM_{AB} : FEM_{BA} : FEM_{CD} \\ \frac{6EI}{L^2} \Delta^* : \frac{6EI}{L^2} \Delta^* : \frac{3EI}{L^2} \Delta^* \\ 6 : 6 : 3 \\ 100 \text{ kNm} : 100 \text{ kNm} : 50 \text{ kNm} \end{array}$$

In which we have cancelled the common lengths, sways and flexural rigidities. Once the arbitrary FEMs are in the correct ratio, the same amount of sway,  $\Delta^*$ , has occurred in all members. The above is just the same as choosing  $\Delta^* = \frac{100L^2}{6EI}$ .

### Different Member Lengths

In this scenario, for the following frame, we have,:

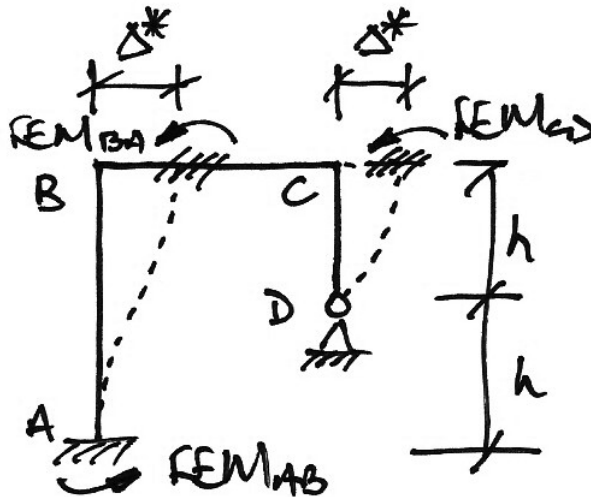

$$FEM_{AB} = FEM_{BA} = \frac{6EI}{(2h)^2} \Delta^*$$

$$FEM_{CD} = \frac{3EI}{h^2} \Delta^*$$

Hence the FEMs must be in the ratio:

$$\begin{array}{l}
 FEM_{AB} \quad : \quad FEM_{BA} \quad : \quad FEM_{CD} \\
 \frac{6EI}{(2h)^2} \Delta^* \quad : \quad \frac{6EI}{(2h)^2} \Delta^* \quad : \quad \frac{3EI}{h^2} \Delta^* \\
 \frac{6}{4} \quad : \quad \frac{6}{4} \quad : \quad 3 \\
 6 \quad : \quad 6 \quad : \quad 12 \\
 1 \quad : \quad 1 \quad : \quad 2 \\
 50 \text{ kNm} \quad : \quad 50 \text{ kNm} \quad : \quad 100 \text{ kNm}
 \end{array}$$

Which could have been achieved by taking  $\Delta^* = \frac{200h^2}{6EI}$ .

### Different Member Stiffnesses

For the following frame, we have:

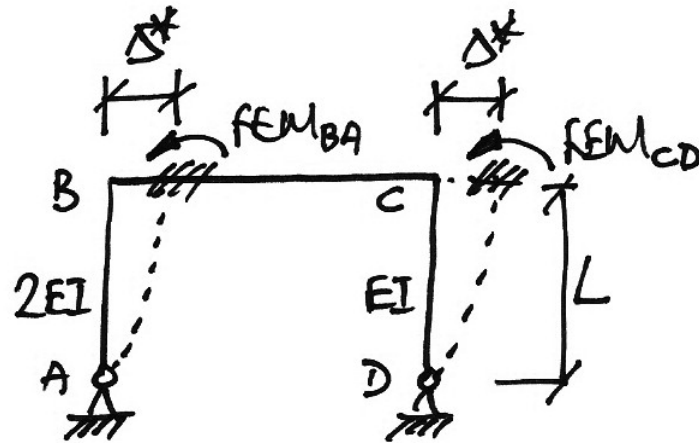

$$FEM_{BA} = \left( \frac{3EI}{L^2} \right)_{AB} \Delta^*$$

$$FEM_{CD} = \left( \frac{3EI}{L^2} \right)_{CD} \Delta^*$$

Hence the FEMs must be in the ratio:

$$\begin{aligned} FEM_{BA} & : FEM_{CD} \\ \frac{3(2EI)}{L^2} \Delta^* & : \frac{3EI}{L^2} \Delta^* \\ 6 & : 3 \\ 2 & : 1 \\ 100 \text{ kNm} & : 50 \text{ kNm} \end{aligned}$$

And this results is just the same as choosing  $\Delta^* = \frac{100L^2}{6EI}$ .

**Class Problems**

Determine an appropriate set of arbitrary moments for the following frames:

<p>1.</p>	
<p>2.</p>	
<p>3.</p>	

### 5.5 Example 11: Rectangular Sway Frame

#### Problem

Analyse the following prismatic frame for all load effects:

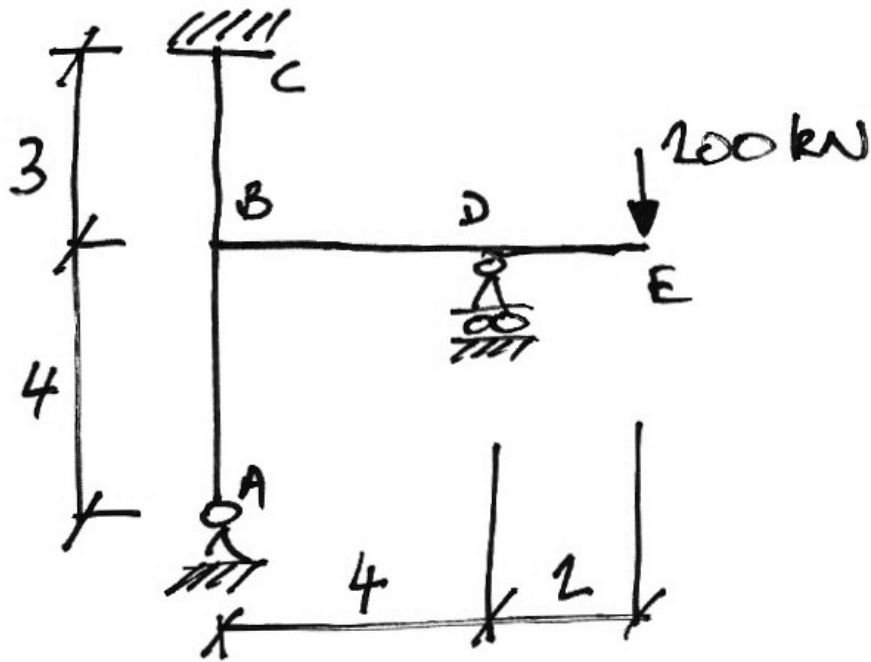

#### Solution

We recognize that this is a sway frame and that a two-stage analysis is thus required.

Place a prop at *D* to prevent sway, which gives the following two-stage analysis:

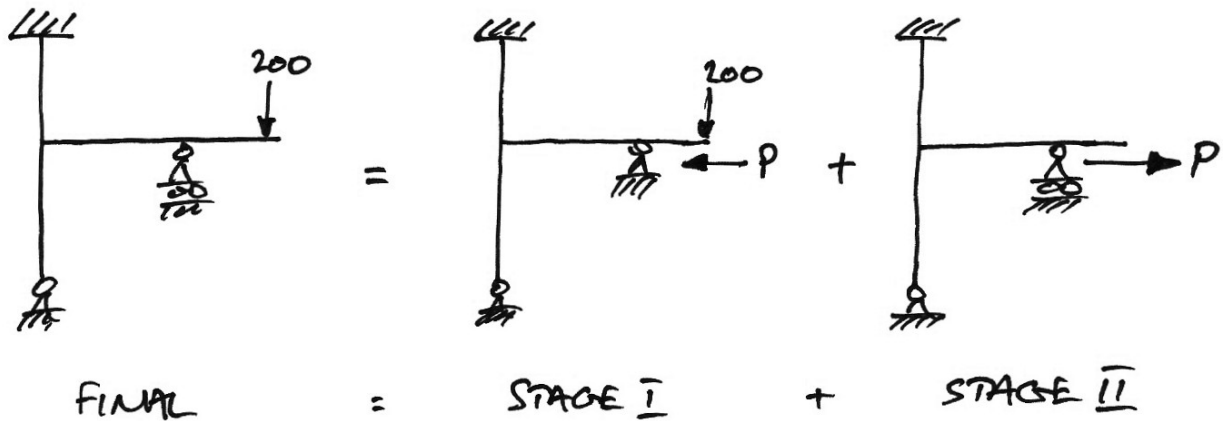

### Stage I Analysis

The Stage I analysis is Problem 1 of Section 4.5 and so the solution is only outlined.

#### 1. Stiffnesses:

- AB:  $k'_{AB} = \frac{3}{4} \left( \frac{EI}{L} \right)_{AB} = \frac{3}{4} \cdot \frac{1}{4} = \frac{3}{16}$
- BC:  $k_{BC} = \frac{1}{3}$
- BD:  $k'_{BD} = \frac{3}{4} \cdot \frac{1}{4} = \frac{3}{16}$

#### 2. Distribution Factors:

- Joint B:

$$\sum k = \frac{3}{16} + \frac{1}{3} + \frac{3}{16} = \frac{34}{48}$$

$$DF_{BA} = \frac{9/48}{34/48} = 0.26 \quad DF_{BC} = \frac{9/48}{34/48} = 0.26 \quad DF_{BD} = \frac{16/48}{34/48} = 0.48$$

Notice that the DFs are rounded to ensure that  $\sum DFs = 1$ .



3. Fixed-End Moments:

- Span  $DE$ :

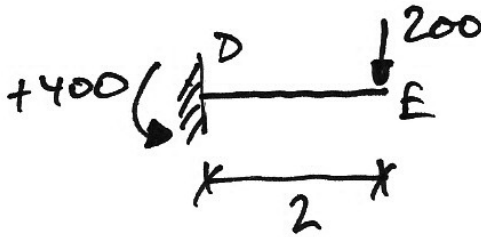

$$FEM_{DE} = 200 \cdot 2 = +400 \text{ kNm}$$

4. Moment Distribution Table:

Joint	A		B		C	D		E
Member	AB	BA	BD	BC	CB	DB	DE	ED
DF		0.26	0.26	0.48		1	0	
FEM							+400	
Dist.						-400		
C.O.			-200					
Dist.		+52	+52	+96				
C.O.					+48			
Final	0	+52	-148	+96	+48	-400	+400	

5. End Shears and Forces:

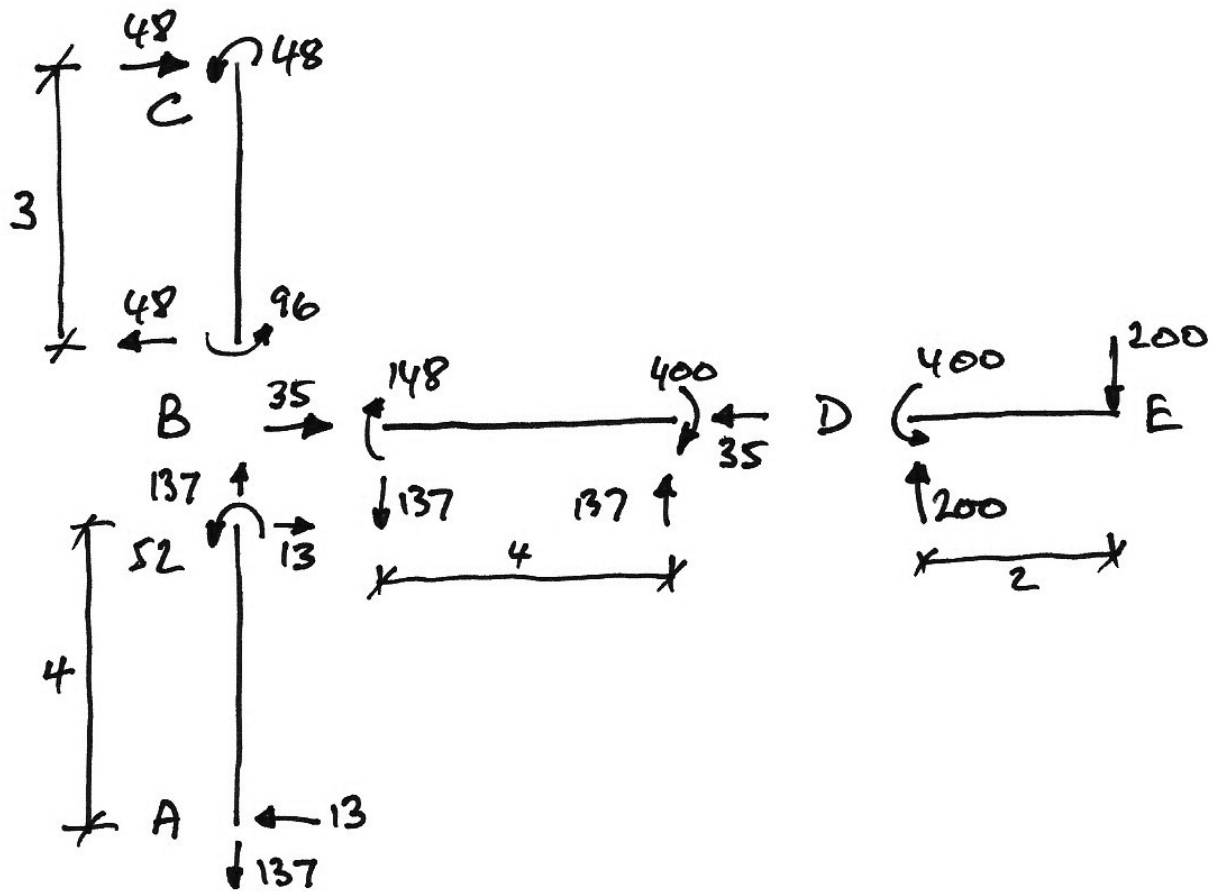

Horizontal equilibrium of Joint  $B$  is:

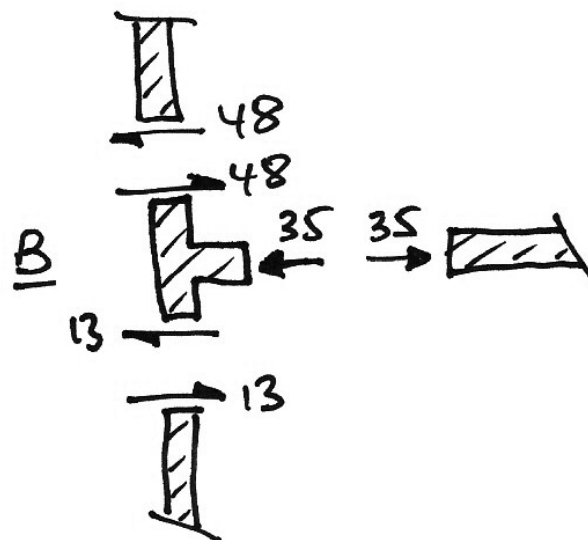

Hence the prop force, which is the horizontal reaction at  $D$ , is 35 kN  $\leftarrow$ .

**Stage II Analysis**

We allow the frame to sway, whilst keeping the joints locked against rotation:

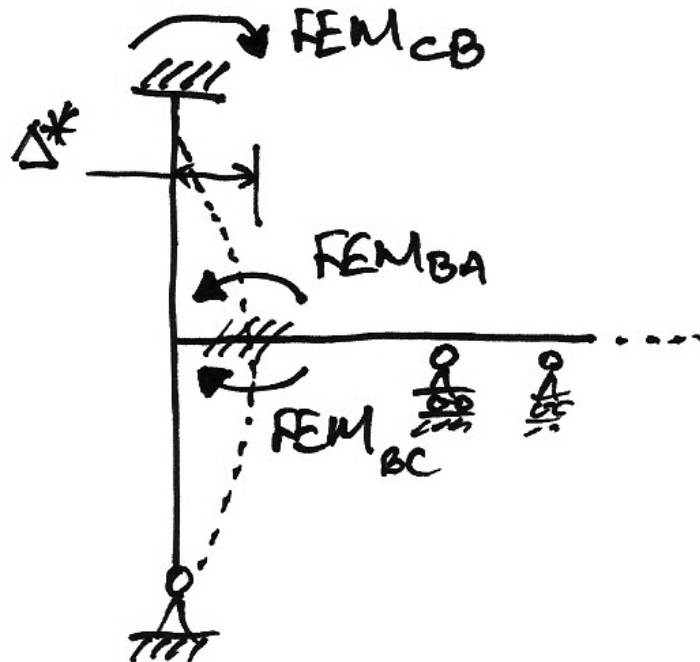

The associated arbitrary FEMs are in the ratio:

$$\begin{array}{l}
 FEM_{CB} \quad : \quad FEM_{BC} \quad : \quad FEM_{BA} \\
 -\frac{6EI}{3^2} \Delta^* \quad : \quad -\frac{6EI}{3^2} \Delta^* \quad : \quad +\frac{3EI}{4^2} \Delta^* \\
 -\frac{6}{9} \quad : \quad -\frac{6}{9} \quad : \quad +\frac{3}{16} \\
 -96 \text{ kNm} \quad : \quad -96 \text{ kNm} \quad : \quad +27 \text{ kNm}
 \end{array}$$

The arbitrary sway associated with these FEMs is:

$$\begin{aligned}
 \frac{6EI}{3^2} \Delta^* &= 96 \\
 \Delta^* &= \frac{144}{EI}
 \end{aligned}$$

And so with these FEMs we analyse for the arbitrary sway force,  $P^*$ :

Joint	A		B		C	D		E
Member	AB	BA	BD	BC	CB	DB	DE	ED
DF		0.26	0.26	0.48		1	0	
FEM		+27		-96	-96			
Dist.		+17.9	+17.9	+33.2				
C.O.					+16.6			
Final	0	+44.9	+17.9	-62.8	-79.4			

The associated member end forces and shears are:

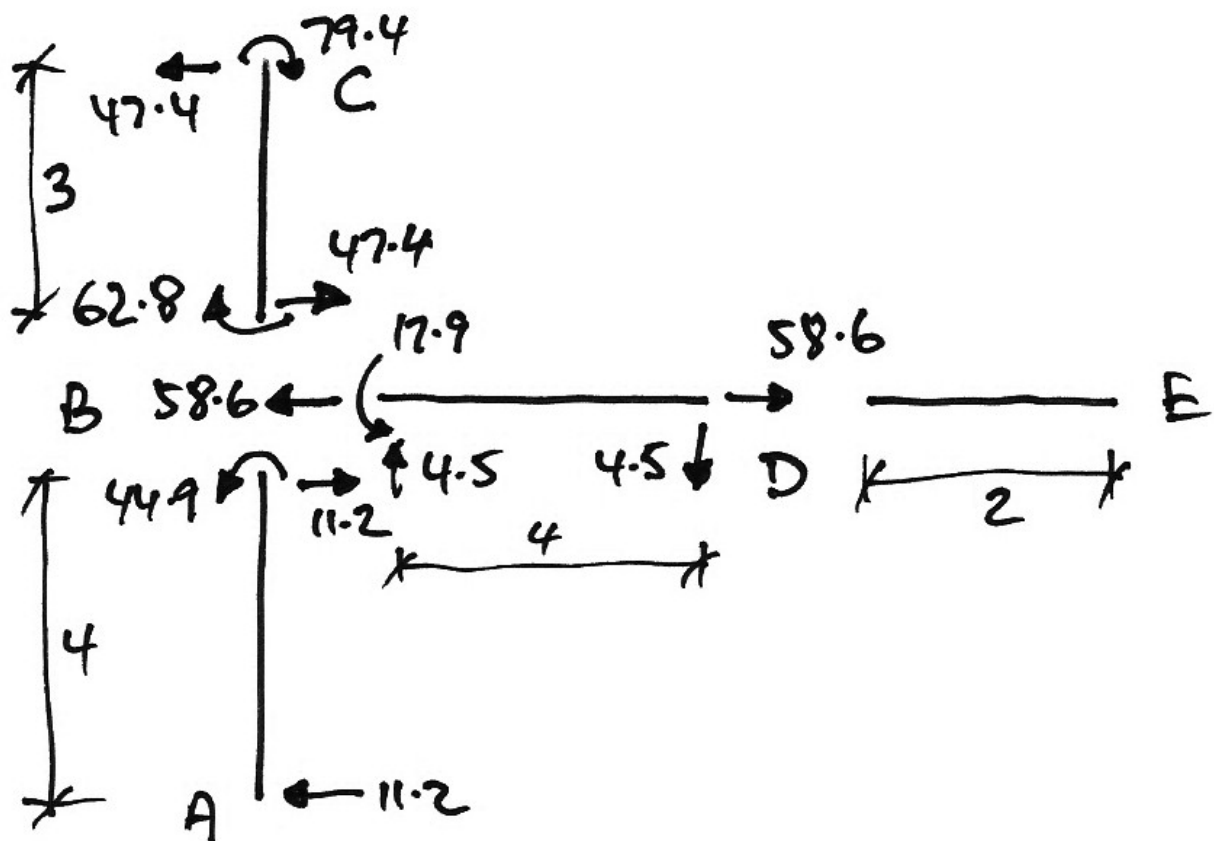

From which we see that  $P^* = 58.6$  kN. Hence:

$$\alpha = \frac{P}{P^*} = \frac{35}{58.6} = 0.597$$

To find the final moments, we can use a table:

Joint	A		B		C	D		E
Member	AB	BA	BD	BC	CB	DB	DE	ED
Stage II* ( $M_{II}^*$ )	0	+44.9	+17.9	-62.8	-79.4			
Stage II ( $M_{II}$ )	0	+26.8	+10.7	-37.5	-47.4			
Stage I ( $M_I$ )	0	+52	-148	+96	+48	-400	+400	
Final ( $M$ )	0	+78.8	-137.3	+58.5	+0.6	-400	+400	

Note that in this table, the moments for Stage II are  $M_{II} = \alpha M_{II}^*$  and the final moments are  $M = M_I + M_{II}$ .

The Stage II BMD is:

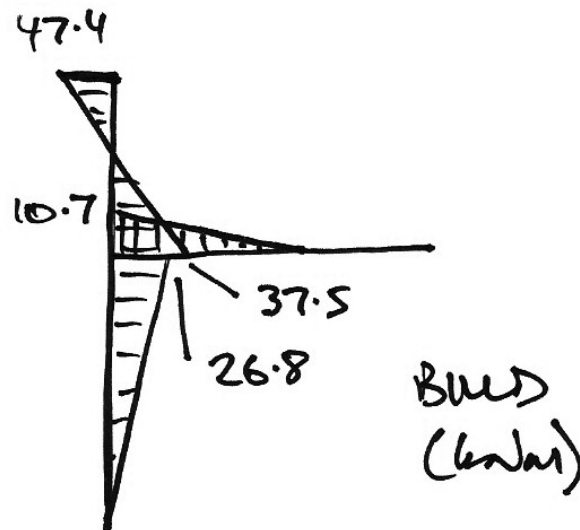

Thus the final member end forces and shears are:

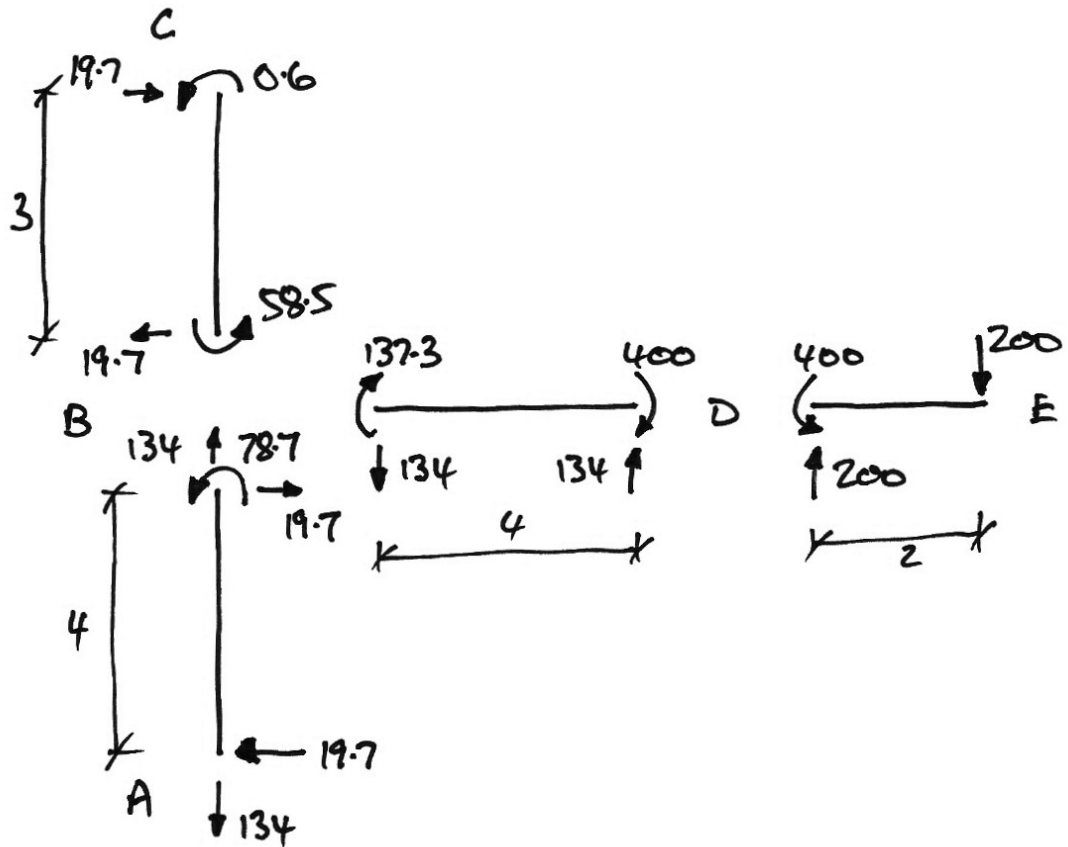

From which we find the reactions and draw the BMD and deflected shape:

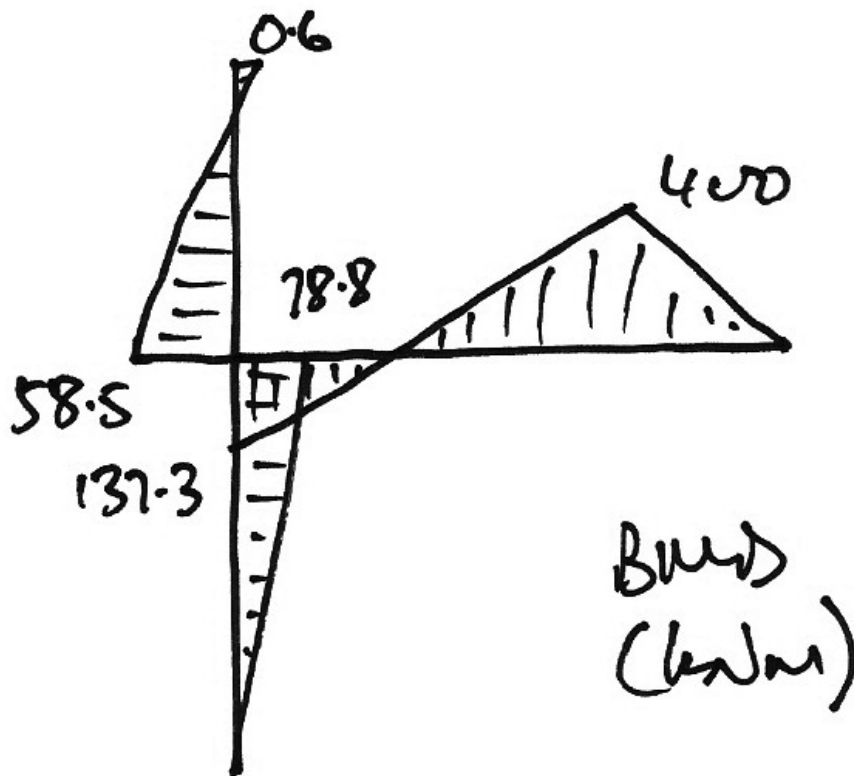

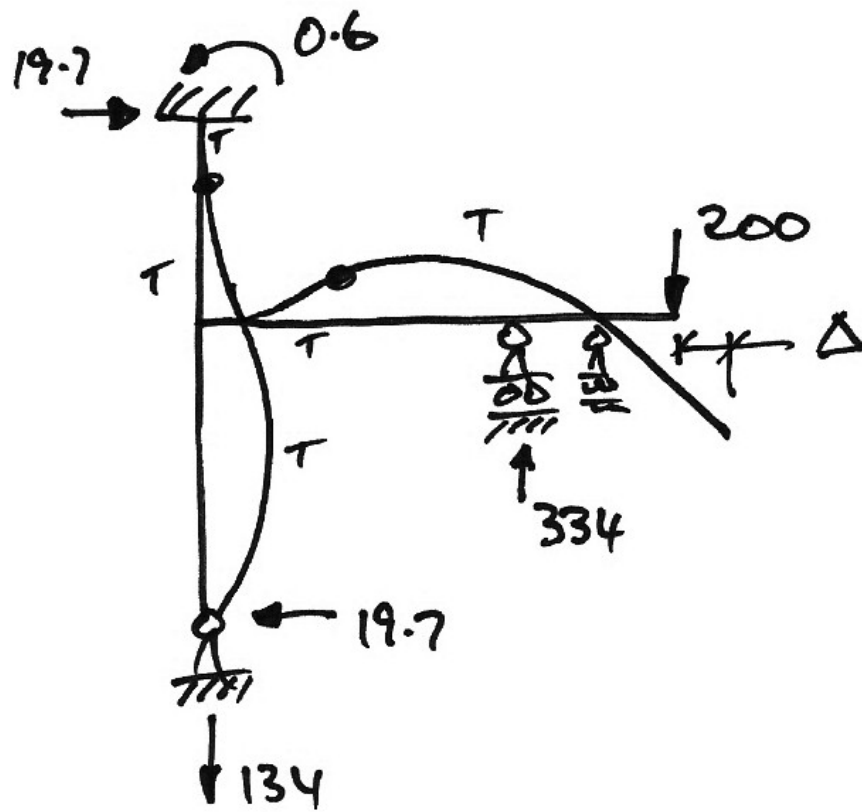

5.6 Problems I

<p>1.</p>		$V_A = 37.4 \text{ kN} \downarrow$ $M_D = +50.3 \text{ kNm}$ $H_D = 0 \text{ kN}$ $V_D = 137.4 \text{ kN} \uparrow$  $M_{BD} = 50.3 \text{ kNm}$ $M_{BA} = 149.7 \text{ kNm}$ $M_{BC} = 200 \text{ kNm}$
<p>2.</p>		$M_A = -14.3 \text{ kNm}$ $V_A = 121.4 \text{ kN} \uparrow$ $H_A = 8.6 \text{ kN} \rightarrow$ $M_D = 19.9 \text{ kNm}$ $V_D = 38.6 \text{ kN} \uparrow$ $H_D = 8.6 \text{ kN} \leftarrow$  $M_B = 37.1 \text{ kNm}$ $M_C = 31.5 \text{ kNm}$

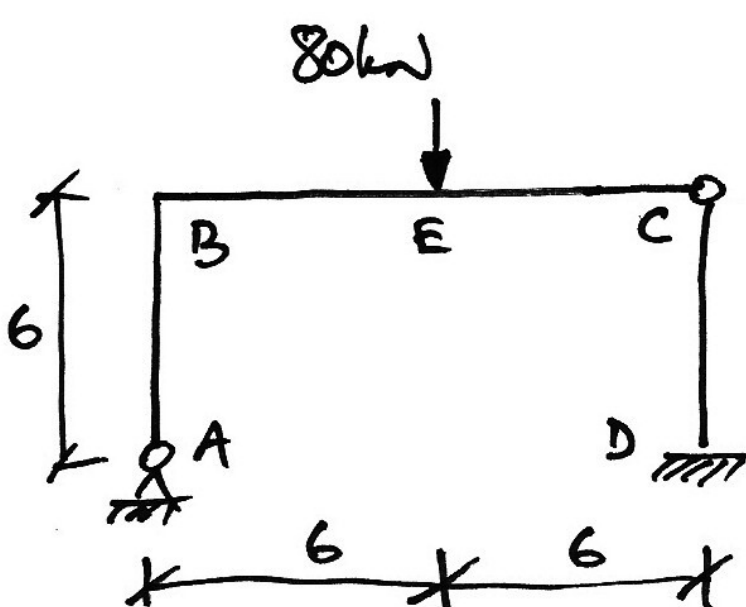
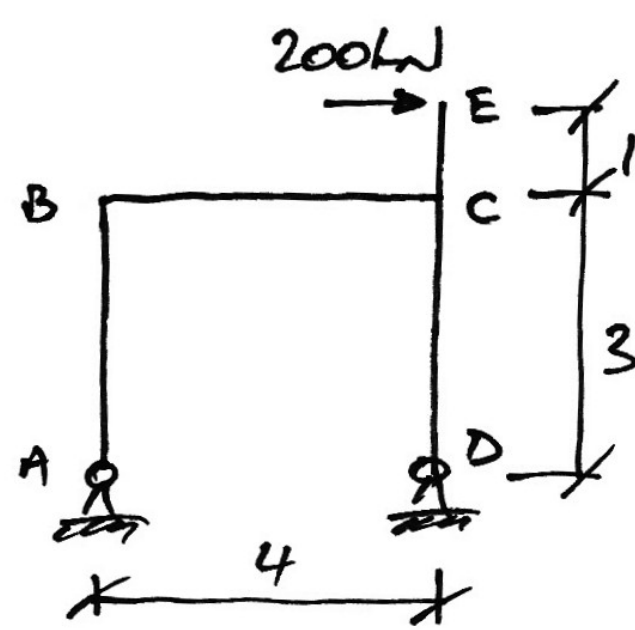

<p>3.</p>	<p>Summer 1998</p> 	<p> <math>V_A = 47.5 \text{ kN} \uparrow</math>  <math>H_A = 15 \text{ kN} \rightarrow</math>  <math>M_D = +90 \text{ kNm}</math>  <math>V_D = 32.5 \text{ kN} \uparrow</math>  <math>H_D = 15 \text{ kN} \leftarrow</math>    <math>M_B = 90.0 \text{ kNm}</math> </p>
<p>4.</p>	<p>Summer 2000</p> 	<p> <math>V_A = 200 \text{ kN} \downarrow</math>  <math>H_A = 122 \text{ kN} \leftarrow</math>  <math>V_D = 200 \text{ kN} \uparrow</math>  <math>H_D = 78 \text{ kN} \rightarrow</math>    <math>M_B = 366 \text{ kNm}</math>  <math>M_{CB} = 433 \text{ kNm}</math>  <math>M_{CD} = 233 \text{ kNm}</math> </p>

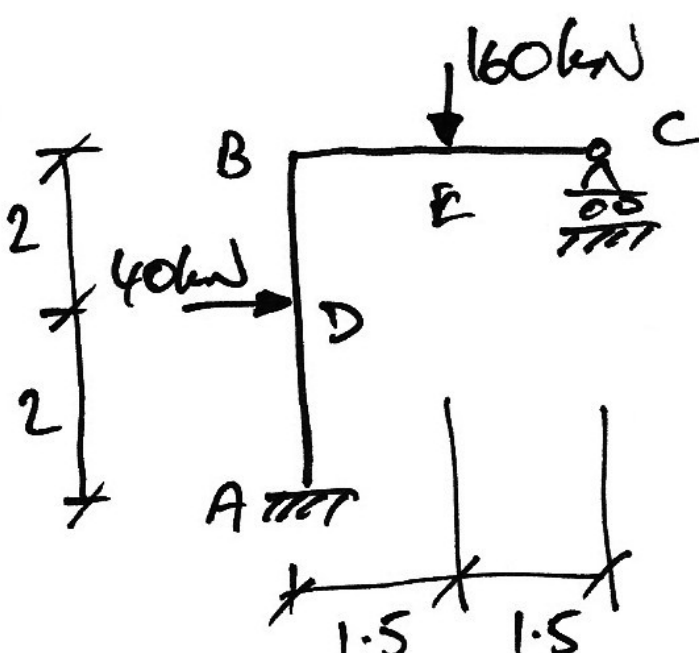
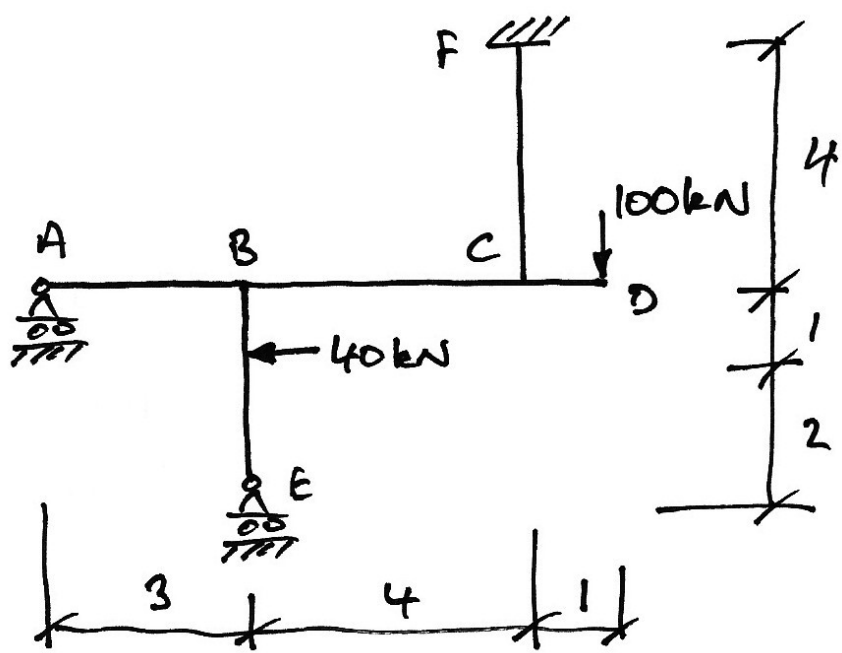
<p>5.</p>	<p>Summer 2001</p> 	<p> <math>M_A = +82 \text{ kNm}</math>  <math>V_A = 81 \text{ kN} \uparrow</math>  <math>H_A = 40 \text{ kN} \leftarrow</math>  <math>V_C = 79 \text{ kN} \uparrow</math>    <math>M_B = 2 \text{ kNm}</math> </p>
<p>6.</p>	<p>Summer 2005</p> 	<p> <math>V_A = 5.1 \text{ kN} \uparrow</math>  <math>V_E = 56 \text{ kN} \downarrow</math>  <math>M_F = +118 \text{ kNm}</math>  <math>V_F = 150 \text{ kN} \uparrow</math>  <math>H_F = 40 \text{ kN} \leftarrow</math>    <math>M_{BA} = 15.4 \text{ kNm}</math>  <math>M_{BC} = 55.4 \text{ kNm}</math>  <math>M_{CF} = 42.4 \text{ kNm}</math>  <math>M_{CB} = 142.4 \text{ kNm}</math> </p>

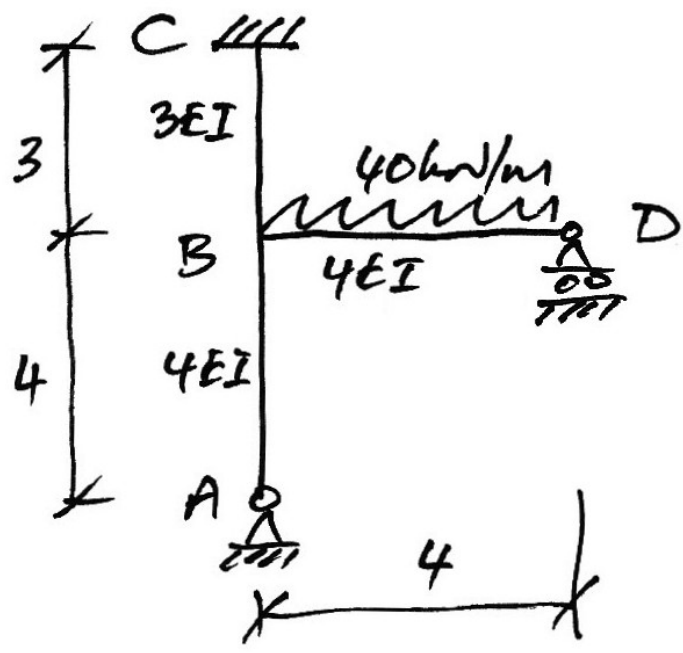
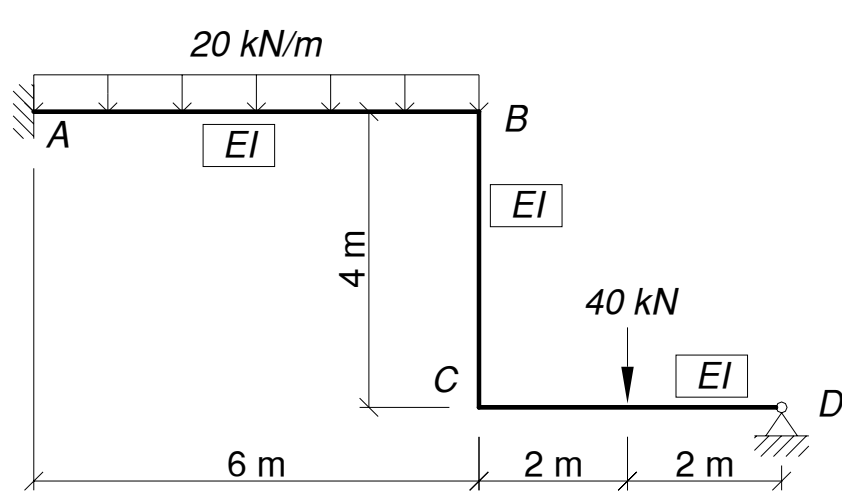
<p>7.</p>	<p>Summer 2006</p> 	<p> <math>V_A = 93.3 \text{ kN} \uparrow</math>  <math>H_A = 8.1 \text{ kN} \rightarrow</math>  <math>M_C = -3.2 \text{ kNm}</math>  <math>V_C = 0 \text{ kN}</math>  <math>H_C = 8.1 \text{ kN} \leftarrow</math>  <math>V_D = 66.7 \text{ kN} \uparrow</math>   <math>M_{BA} = 32.2 \text{ kNm}</math>  <math>M_{BD} = 53.3 \text{ kNm}</math>  <math>M_{BC} = 21.0 \text{ kNm}</math> </p>
<p>8.</p>	<p>Semester 1 2007/8</p> 	<p> <math>M_A = 249.2 \text{ kNm}</math>  <math>M_B = 73.8 \text{ kNm}</math>  <math>M_C = 104 \text{ kNm}</math>  <math>M_E = 92 \text{ kNm}</math> </p>

### 5.7 Arbitrary Sway of Oblique Frames Using Geometry

#### Description

The sway of these types of members is more complicated. In sketching the deflected shape of the frame, we must remember the following:

1. We ignore axial shortening of members;
2. Members only deflect perpendicular to their longitudinal axis.

Based on these small-displacement assumptions, a sample sway frame in which the joints are locked against rotation, but allowed to sway is:

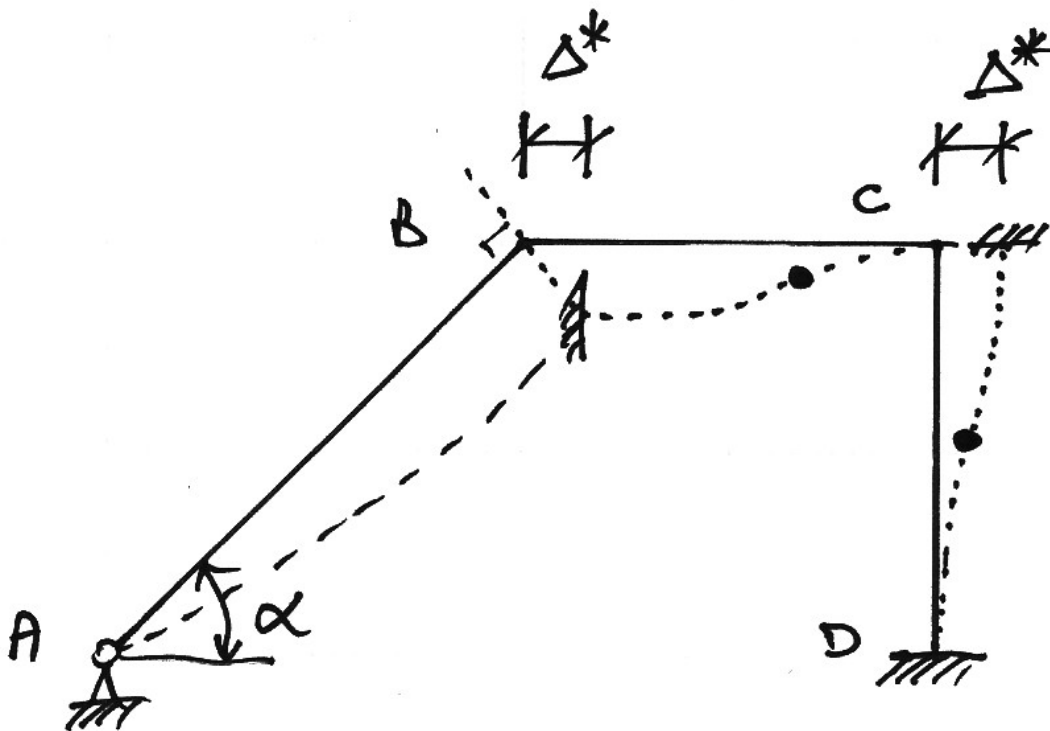

Notice that since member  $BC$  does not change length, both joints  $B$  and  $C$  move laterally an equal amount  $\Delta^*$ . Also, since joint  $B$  must deflect normal to member  $AB$  it must move downwards as shown. Notice that the vertical component of sway at joint  $B$ ,  $\Delta_{BC}^*$ , causes sway moments to occur in the beam member  $BC$ . Looking more closely at the displacements at joint  $B$ , we have the following diagram:

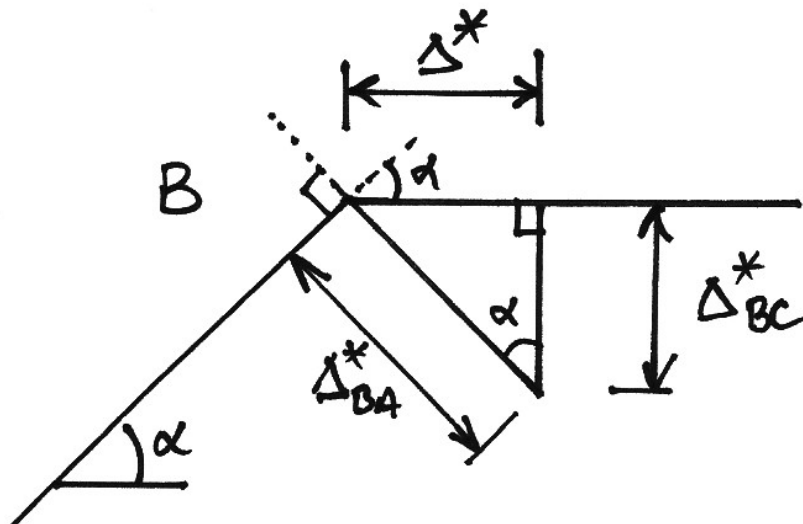

And from the joint displacements it is apparent that the lateral sway of  $B$ ,  $\Delta^*$ , is related to the vertical sway,  $\Delta^*_{BC}$ , and the sway normal to member  $AB$ ,  $\Delta^*_{BA}$ , through the right-angled triangle shown. This triangle can be related slope of member  $AB$  using similar triangles:

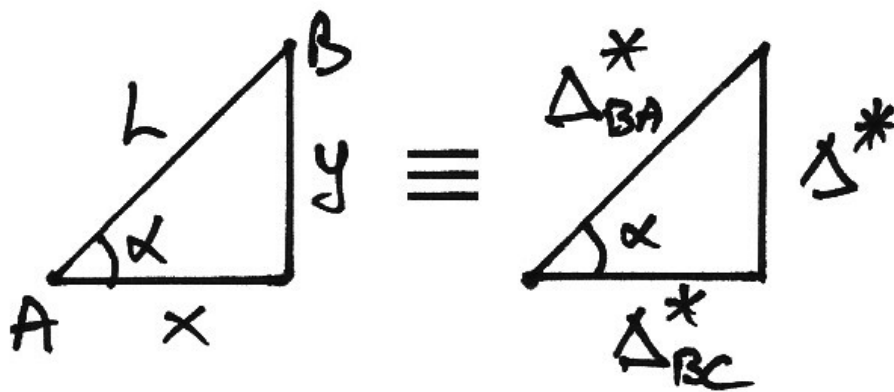

$$\frac{L}{y} = \frac{\Delta^*_{BA}}{\Delta^*} \Rightarrow \Delta^*_{BA} = \Delta^* \frac{L}{y}$$

$$\frac{x}{y} = \frac{\Delta^*_{BC}}{\Delta^*} \Rightarrow \Delta^*_{BC} = \Delta^* \frac{x}{y}$$

Using these relationships, the fixed end moments are then:

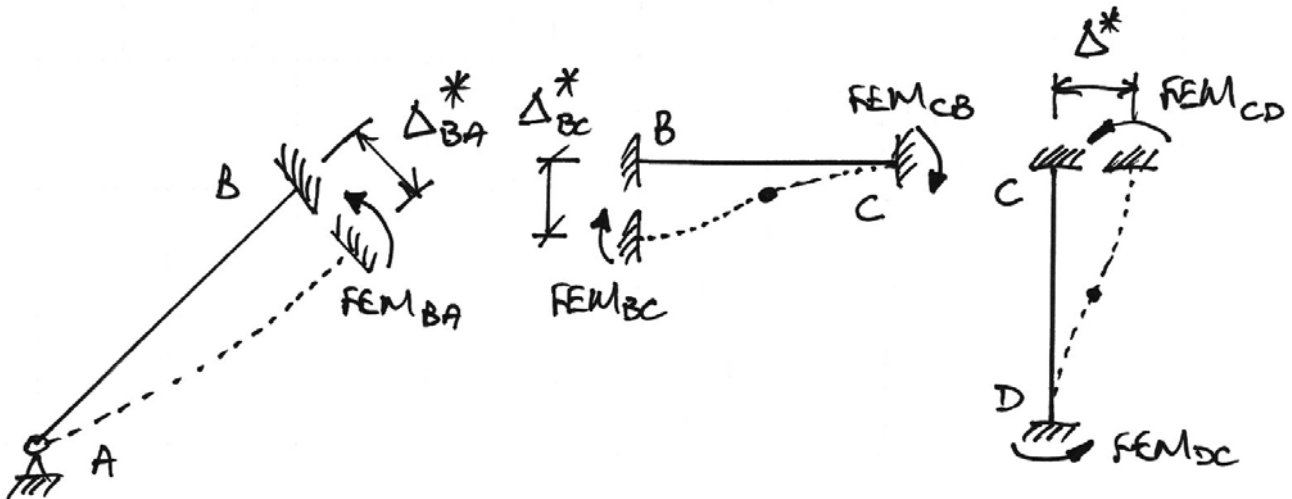

And so, considering this frame as prismatic and considering only independent FEMs for brevity (for example,  $FEM_{CB} = FEM_{BC}$  and so we just keep  $FEM_{BC}$ ), we have:

$$\begin{aligned}
 FEM_{BA} & : FEM_{BC} & : FEM_{CD} \\
 \left( \frac{3EI\Delta^*}{L^2} \right)_{AB} & : \left( \frac{6EI\Delta^*}{L^2} \right)_{BC} & : \left( \frac{6EI\Delta^*}{L^2} \right)_{CD} \\
 \frac{\Delta_{BA}^*}{L_{AB}^2} & : \frac{\Delta_{BC}^*}{L_{BC}^2} & : \frac{\Delta^*}{L_{CD}^2}
 \end{aligned}$$

Using the relationships between the various displacements previously established (for example,  $\Delta_{BA}^* = (L_{AB}/y) \cdot \Delta^*$ ) gives:

$$\begin{aligned}
 \frac{L_{AB}}{y} \cdot \frac{\Delta^*}{L_{AB}^2} & : \frac{x}{y} \cdot \frac{\Delta^*}{L_{BC}^2} & : \frac{\Delta^*}{L_{AB}^2} \\
 \frac{1}{L_{AB}y} & : \frac{x}{L_{BC}^2 y} & : \frac{1}{L_{AB}^2}
 \end{aligned}$$

Thus correct ratios between the arbitrary FEMs are established.

**Numerical Example**

For the following frame, determine a set of arbitrary FEMs:

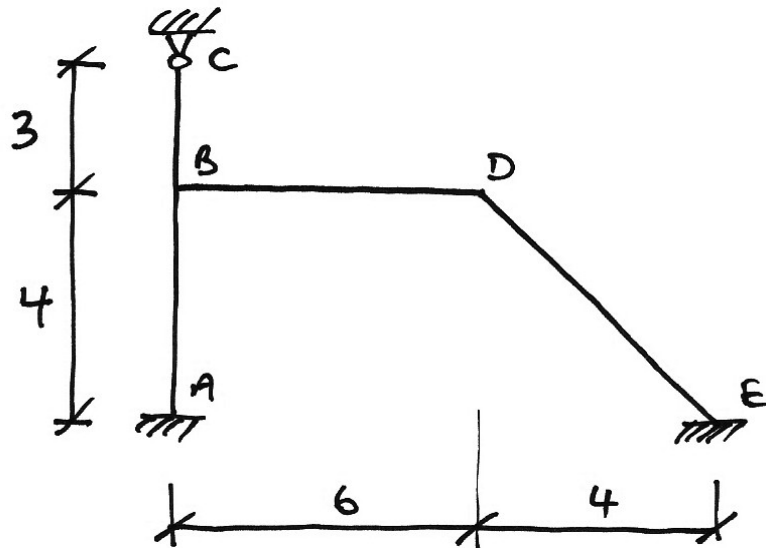

Firstly, we draw the sway configuration, keeping all joints locked against rotation:

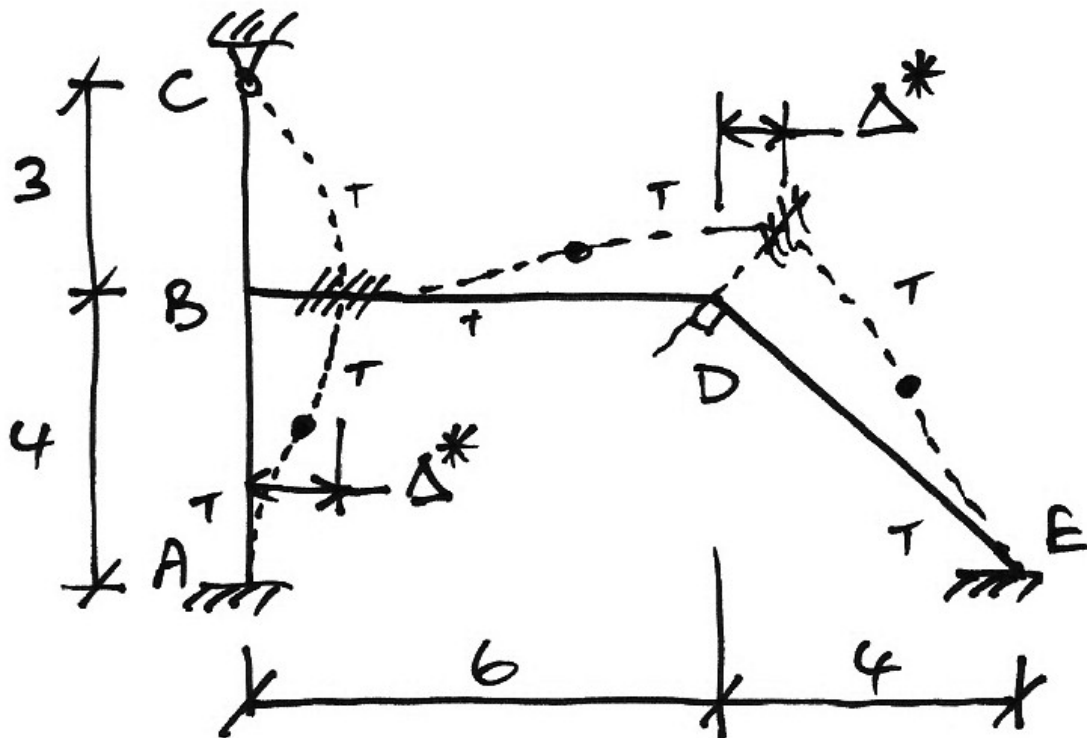

Evidently, the FEMs for members  $AB$  and  $BC$  are directly related to the arbitrary sway,  $\Delta^*$ . For members  $DB$  and  $DE$  we need to consider joint  $D$  carefully:

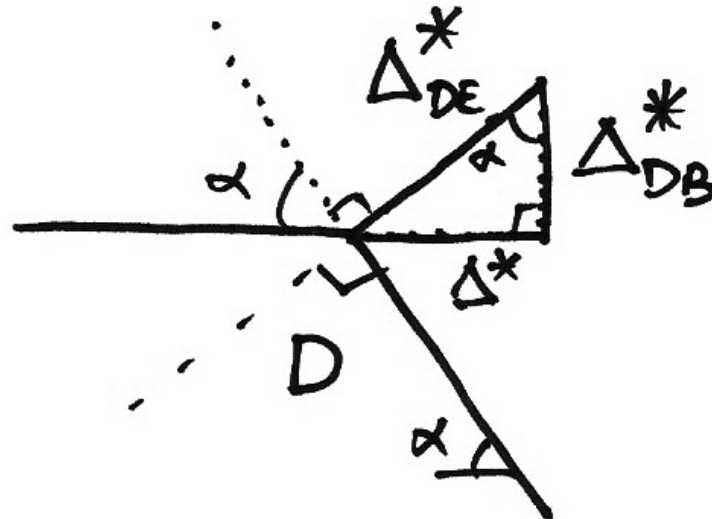

Linking the displacement triangle to the geometry of member  $DE$  we have the similar triangles:

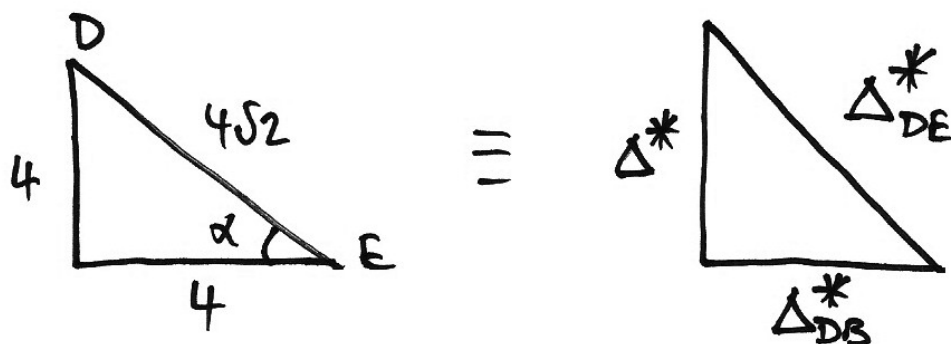

Hence:

$$\frac{\Delta_{DE}^*}{\Delta^*} = \frac{4\sqrt{2}}{4} \Rightarrow \Delta_{DE}^* = \Delta^* \sqrt{2}$$

$$\frac{\Delta_{DB}^*}{\Delta^*} = \frac{4}{4} \Rightarrow \Delta_{DB}^* = 1 \cdot \Delta^*$$



Considering the FEMs as they relate to the sway configuration, we have:

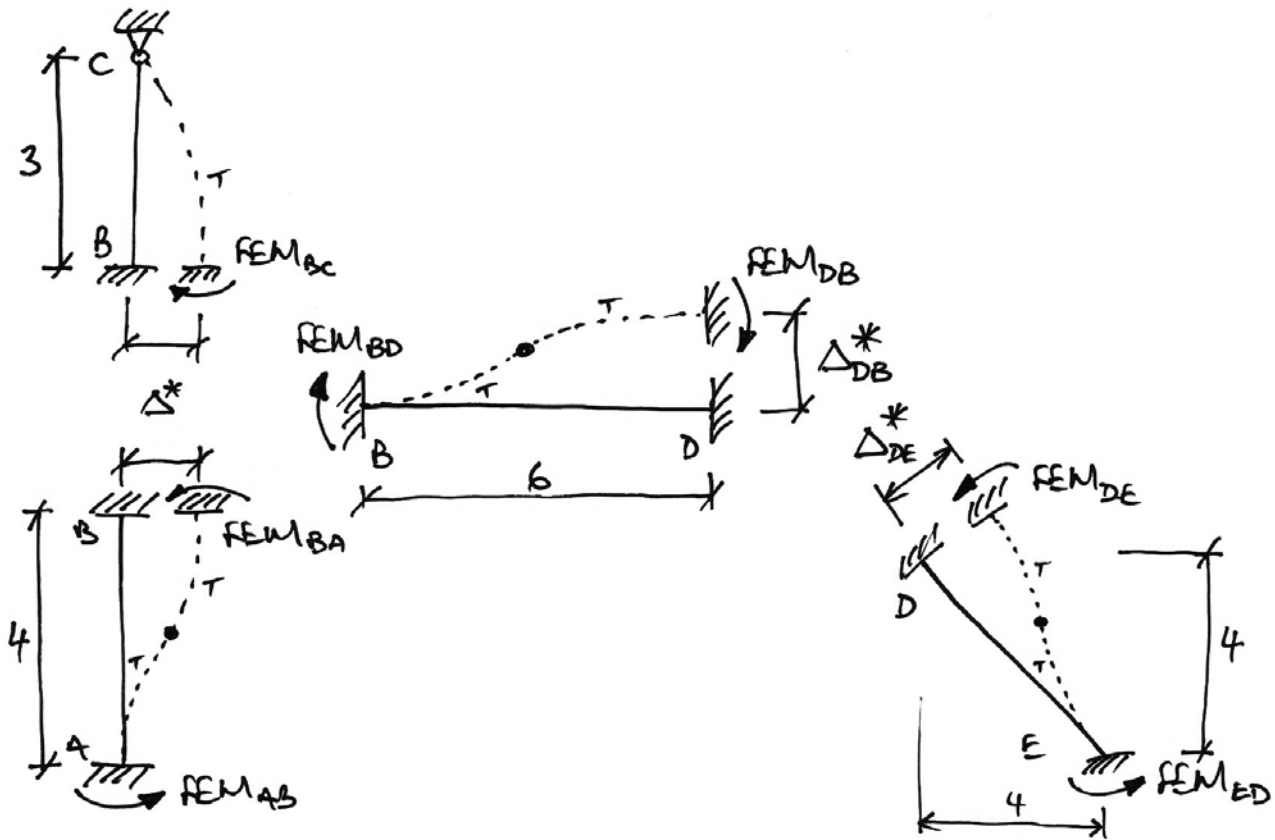

$$\begin{array}{cccc}
 FEM_{BA} & : & FEM_{BC} & : & FEM_{DB} & : & FEM_{DE} \\
 \left( \frac{6EI\Delta^*}{L^2} \right)_{AB} & : & \left( \frac{3EI\Delta^*}{L^2} \right)_{BC} & : & \left( \frac{6EI\Delta^*}{L^2} \right)_{BD} & : & \left( \frac{6EI\Delta^*}{L^2} \right)_{DE} \\
 \frac{6\Delta^*}{4^2} & : & \frac{3\Delta^*}{3^2} & : & \frac{6\Delta_{DB}^*}{6^2} & : & \frac{6\Delta_{DE}^*}{(4\sqrt{2})^2} \\
 \frac{6\Delta^*}{16} & : & \frac{3\Delta^*}{9} & : & \frac{6(1 \cdot \Delta^*)}{36} & : & \frac{6(\Delta^* \sqrt{2})}{32} \\
 \frac{6}{16} & : & \frac{3}{9} & : & \frac{1}{6} & : & \frac{6\sqrt{2}}{32} \\
 108 \text{ kNm} & : & 96 \text{ kNm} & : & 48 \text{ kNm} & : & 76.4 \text{ kNm}
 \end{array}$$

**Class Problems**

Determine an appropriate set of arbitrary moments for the following frames:

<p>1.</p>	
<p>2.</p>	
<p>3.</p>	

**5.8 Example 12: Oblique Sway Frame I**

**Problem – Autumn 2007**

Using moment distribution, analyse the following frame for the reactions, deflected shape and bending moment diagrams:

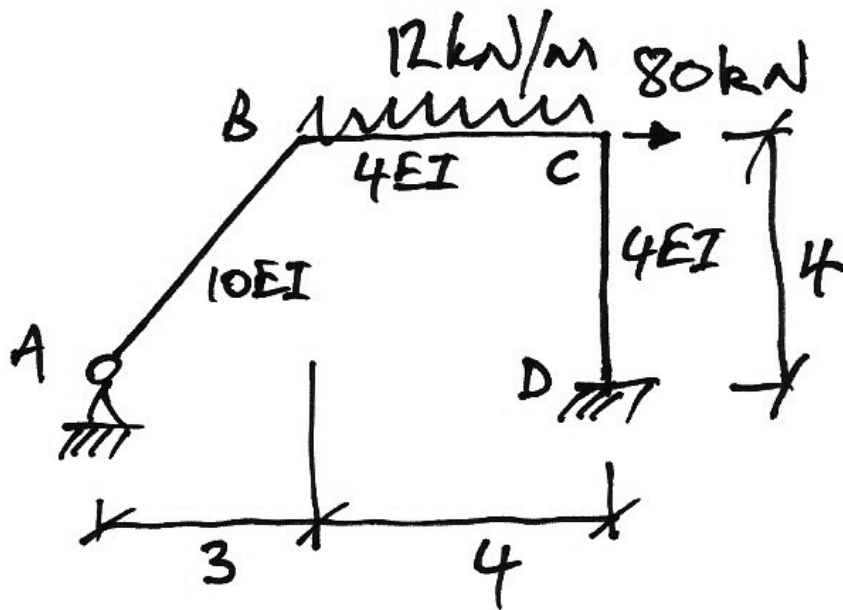

**Solution**

We recognize that this is a sway frame and that a two-stage analysis is required. We put a prop at C to prevent sway, which gives the following two-stage analysis:

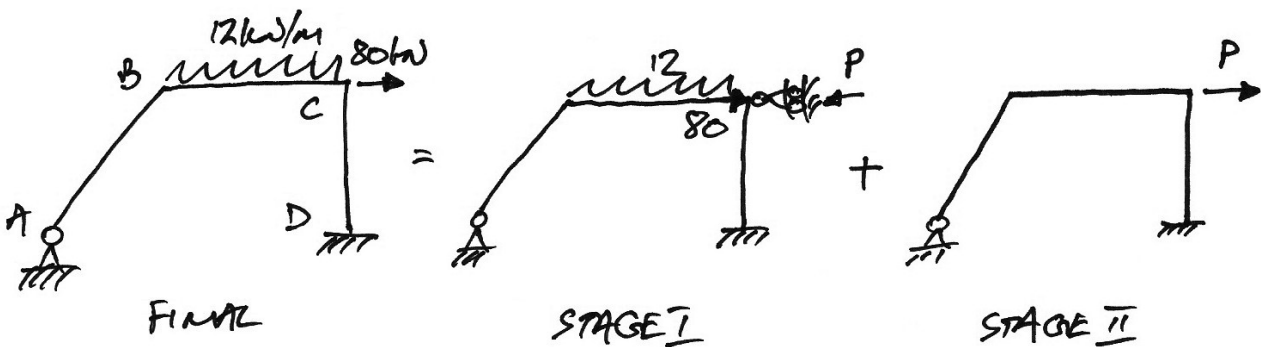

### Stage I Analysis

#### 1. Stiffnesses:

- $AB$ :  $k'_{AB} = \frac{3}{4} \left( \frac{EI}{L} \right)_{AB} = \frac{3}{4} \cdot \frac{10EI}{5} = \frac{3}{2}$
- $BC$ :  $k_{BC} = \left( \frac{EI}{L} \right)_{BC} = \frac{4EI}{4} = 1$
- $BD$ :  $k_{BD} = \left( \frac{EI}{L} \right)_{BD} = \frac{4EI}{4} = 1$

#### 2. Distribution Factors:

- Joint  $B$ :

$$\sum k = \frac{3}{2} + 1 = \frac{5}{2} \quad \Rightarrow \quad DF_{BA} = \frac{3/2}{5/2} = 0.6 \quad DF_{BC} = \frac{2/2}{5/2} = 0.4$$

- Joint  $C$ :

$$\sum k = 1 + 1 = 2 \quad \Rightarrow \quad DF_{CB} = \frac{1}{2} = 0.5 \quad DF_{CD} = \frac{1}{2} = 0.5$$

#### 3. Fixed-End Moments:

- Span  $BC$ :

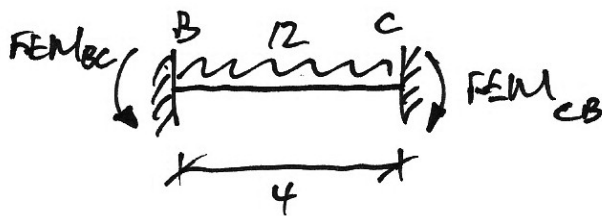

$$FEM_{BC} = + \frac{wL^2}{12} = + \frac{12 \cdot 4^2}{12} = +16 \text{ kNm}$$

$$FEM_{CB} = - \frac{wL^2}{12} = -16 \text{ kNm}$$

Notice that the 80 kN point load at  $C$  does not cause span moments and hence has no FEM. Thus, if the frame was only loaded by the 80 kN point load, there would be no need for a Stage I analysis.

4. Moment Distribution Table:

Joint	A	B		C		D
Member	AB	BA	BC	CB	CD	DE
DF		0.6	0.4	0.5	0.5	0
FEM			+16	-16		
Dist.		-9.6	-6.4	+8	+8	
C.O.						+4
Final	0	-9.6	+9.6	-8	+8	+4

5. End Shears and Forces:

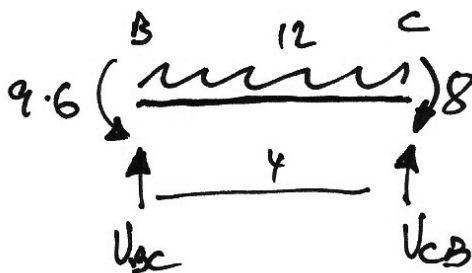

$$\sum M \text{ about } B = 0$$

$$\therefore 12 \cdot \frac{4^2}{2} + 8 - 9.6 - 4V_{CB} = 0$$

$$\therefore V_{CB} = +23.6 \text{ kN}$$

$$\therefore V_D = 23.6 \text{ kN} \uparrow$$

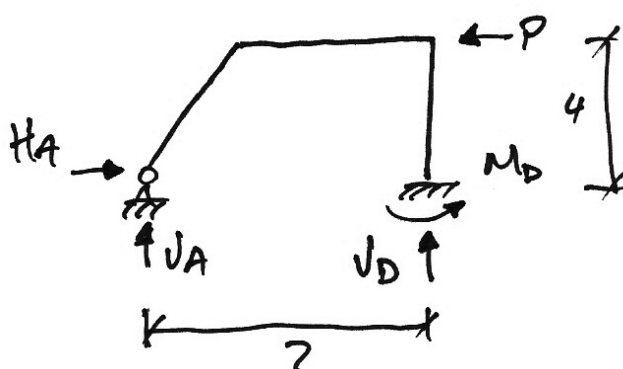

$$\sum M \text{ about } A = 0$$

$$\therefore 12 \cdot 4 \cdot 5 - 23.6 \cdot 7 - 4 - 4P_{UDL} = 0$$

$$\therefore P_{UDL} = +17.7 \text{ kN}$$

$$P = P_{UDL} + P_{80} = 17.7 + 80 = 97.7 \text{ kN}$$

Some points on these calculations are:

- We only solve enough of the structure to find the prop force,  $P$ .

- Since joint  $C$  is a right-angled connection,  $V_{CB}$  of member  $BC$  becomes the axial force in member  $CD$  and so the vertical reaction at  $D$  is  $V_D = 23.6 \text{ kN} \uparrow$  as shown.
- Lastly, the final prop force reaction must allow for both the prop force due to the UDL and the 80 kN which is applied directly to the support.

Sketch this last point:

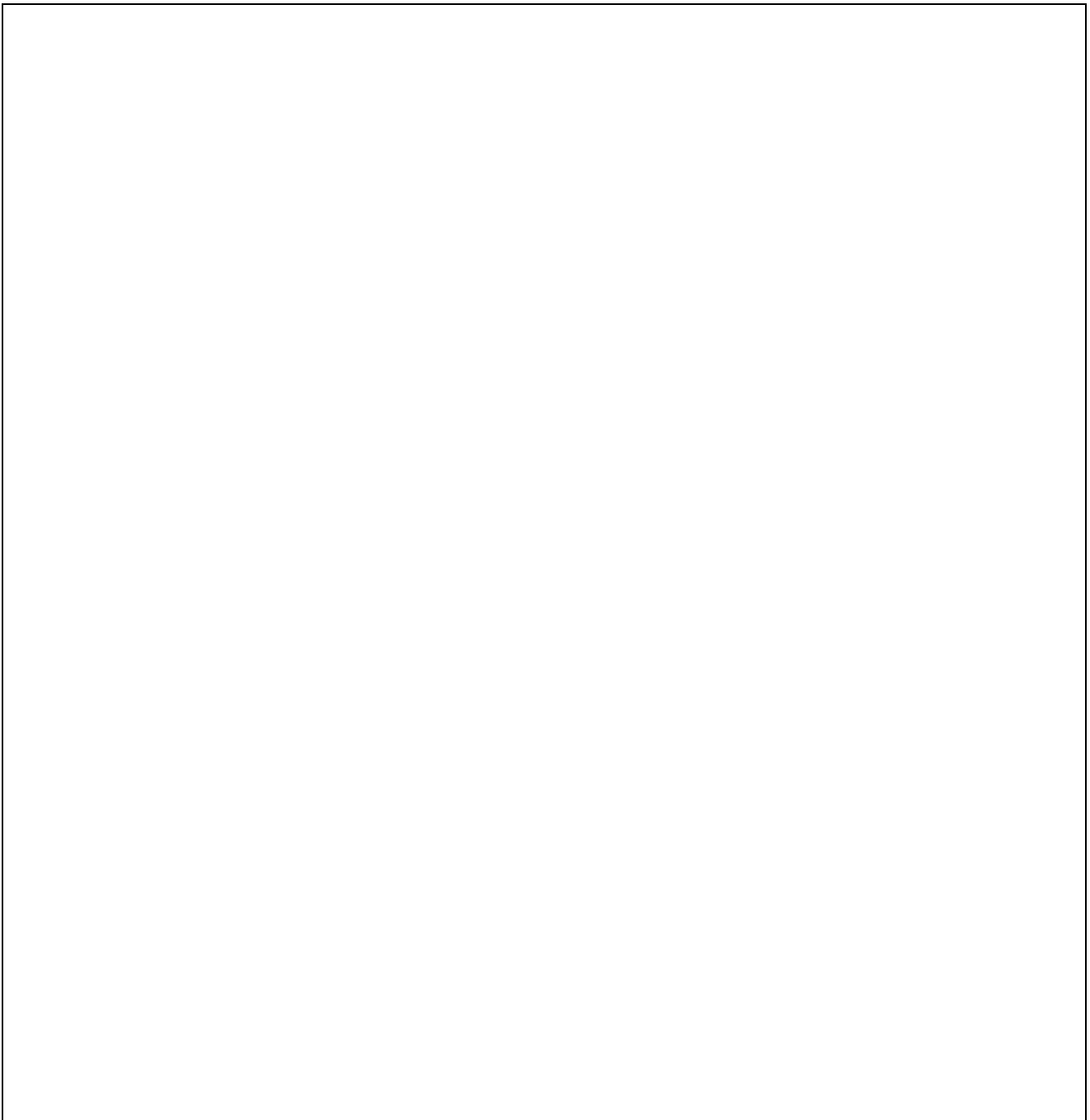

**Stage II Analysis**

We allow the frame to sway, whilst keeping the joints locked against rotation:

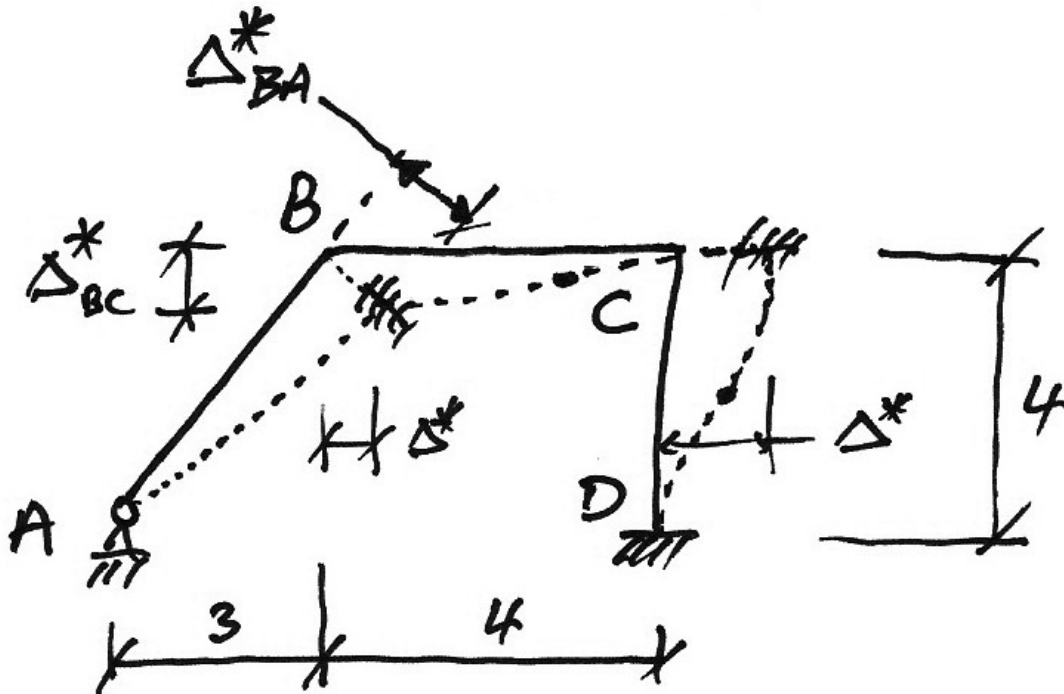

Considering the angle of member  $AB$  as  $\alpha$ , and following that angle around to orientate the displacement triangle at joint  $B$  gives:

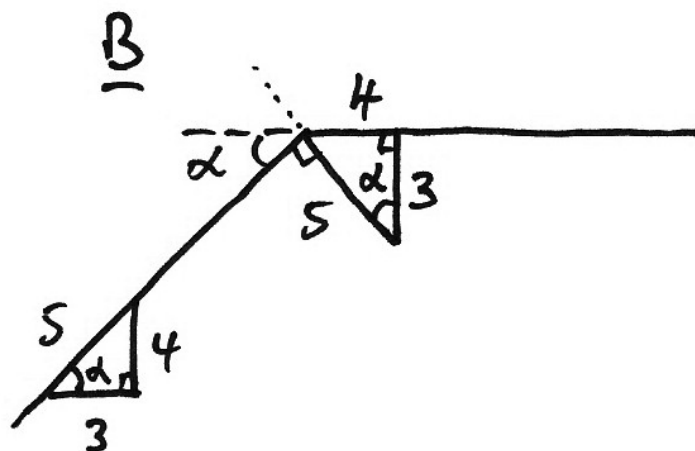

From which we can get the ratios of the arbitrary deflections:

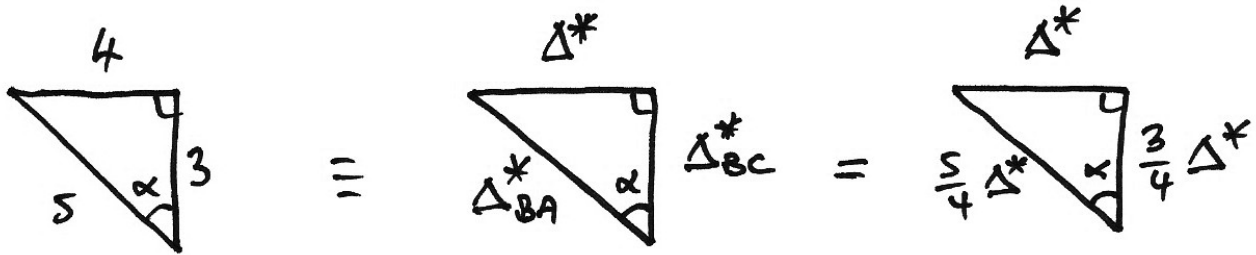

The FEMs are the following:

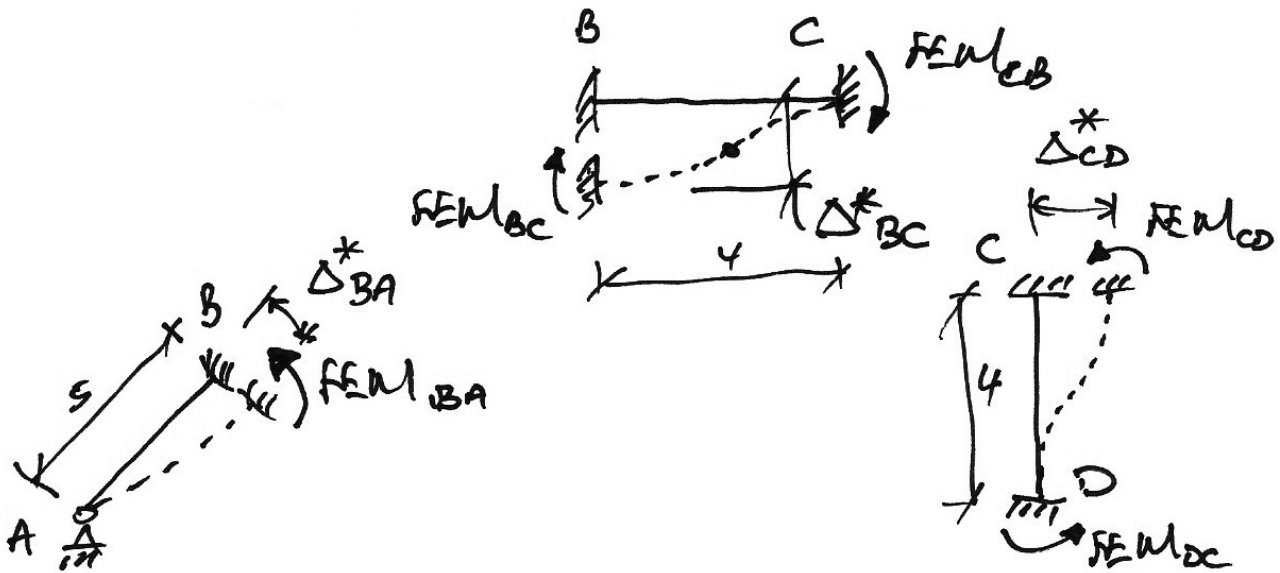

And so we have:

$$\begin{array}{lcl}
 FEM_{BA} & : & FEM_{BC} & : & FEM_{CD} \\
 \left( +\frac{3EI}{L^2} \Delta^* \right)_{AB} & : & \left( -\frac{6EI}{L^2} \Delta^* \right)_{BC} & : & \left( +\frac{6EI}{L^2} \Delta^* \right)_{CD} \\
 +\frac{3(10EI)}{5^2} \Delta_{BA}^* & : & -\frac{6(4EI)}{4^2} \Delta_{BC}^* & : & +\frac{6(4EI)}{4^2} \Delta^* \\
 +\frac{30}{25} \cdot \frac{5}{4} \Delta^* & : & -\frac{24}{16} \cdot \frac{3}{4} \Delta^* & : & +\frac{24}{16} \Delta^* \\
 +240 \text{ kNm} & : & -180 \text{ kNm} & : & +240 \text{ kNm}
 \end{array}$$



The arbitrary sway associated with these FEMs is:

$$\frac{6(4EI)}{4^2} \Delta^* = 240 \Rightarrow \Delta^* = \frac{160}{EI}$$

And so with these FEMs we analyse for the arbitrary sway force,  $P^*$ :

Joint	A	B		C		D
Member	AB	BA	BC	CB	CD	DE
DF		0.6	0.4	0.5	0.5	0
FEM		+240	-180	-180	+240	+240
Dist.		-36	-24	-30	-30	
C.O.						-15
Final	0	+204	-204	-210	+210	+225

Again we only calculate that which is sufficient to find the arbitrary sway force,  $P^*$ :

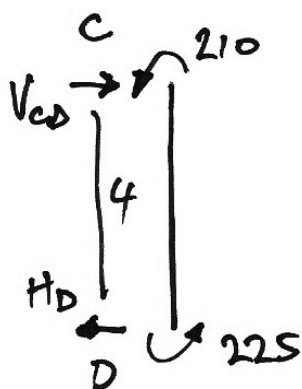

$$\begin{aligned} \sum M \text{ about } C &= 0 \\ \therefore 210 + 225 - 4H_D &= 0 \\ \therefore H_D &= +108.75 \text{ kN } \leftarrow \end{aligned}$$

We consider the portion of the frame  $BCD$ :

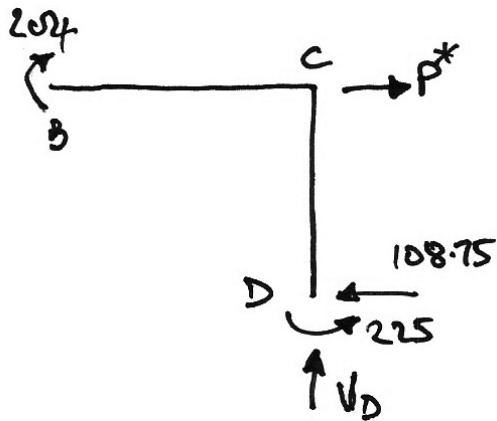

$$\sum M \text{ about } B = 0$$

$$\therefore 204 + 4 \cdot 108.75 - 225 - 4V_D = 0$$

$$\therefore V_D = +103.75 \text{ kN } \uparrow$$

Considering the whole frame, we have:

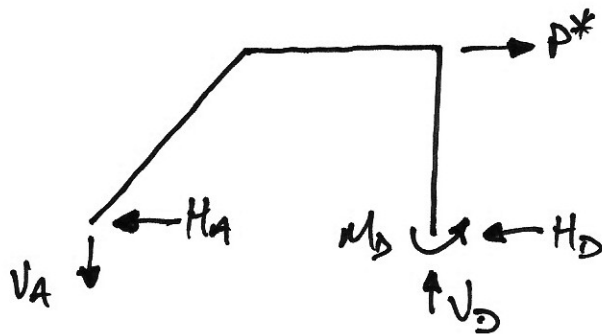

$$\sum F_y = 0$$

$$\therefore V_A - 103.5 = 0$$

$$\therefore V_A = 103.5 \text{ kN } \downarrow$$

And for member AB we have:

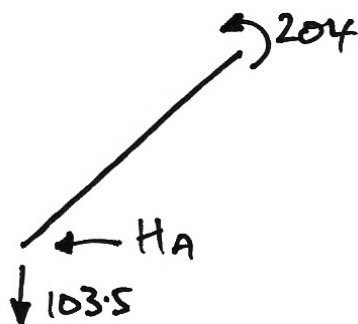

$$\sum M \text{ about } B = 0$$

$$\therefore 204 + 3 \cdot 103.5 - 4H_A = 0$$

$$\therefore H_A = +128.63 \text{ kN } \leftarrow$$

Lastly, we consider the whole frame again:

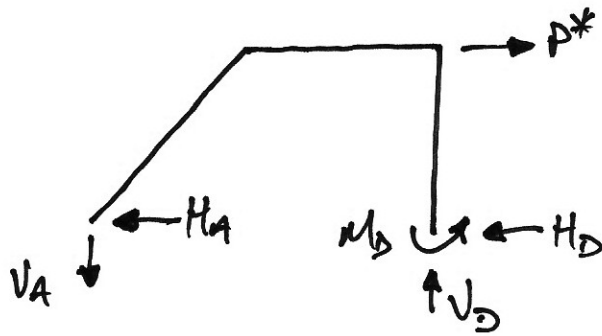

$$\begin{aligned} \sum F_x &= 0 \\ \therefore H_A + H_D - P^* &= 0 \\ \therefore 128.63 + 108.75 - P^* &= 0 \\ \therefore P^* &= 237.43 \text{ kN} \rightarrow \end{aligned}$$

Hence:

$$\alpha = \frac{P}{P^*} = \frac{97.7}{237.43} = 0.4115$$

To find the final moments, we use a table:

Joint	A	B		C		D
Member	AB	BA	BC	CB	CD	DE
Stage II* ( $M_{II}^*$ )	0	+204	-204	-210	+210	+225
Stage II ( $M_{II}$ )	0	+84	-84	-86.4	+86.4	+92.6
Stage I ( $M_I$ )	0	-9.6	+9.6	-8	+8	+4
Final ( $M$ )	0	+74.4	-74.4	-94.4	+94.4	+96.6

Recall the formulae used in the table:  $M_{II} = \alpha M_{II}^*$  and  $M = M_I + M_{II}$ .

Also, the actual sway is

$$\Delta = \alpha \Delta^* = 0.4115 \cdot \frac{144}{EI} = \frac{59.26}{EI}$$

The member forces are:

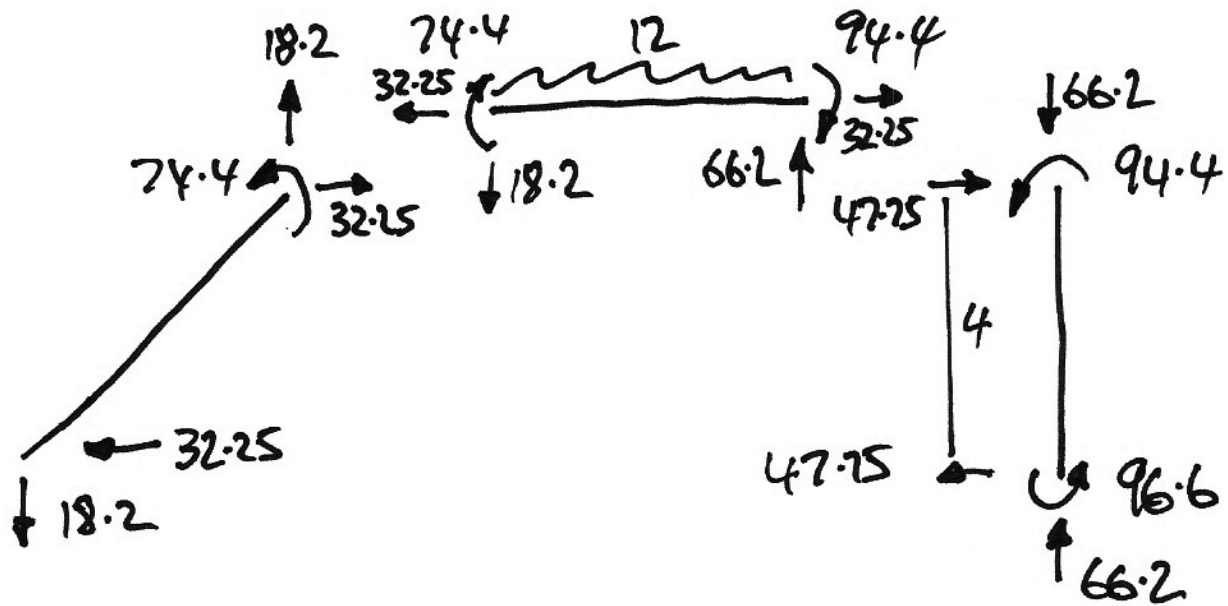

Note that for member  $AB$ , even though the 18.2 kN and 32.25 kN end forces are not the shear and axial force, we can still apply horizontal and vertical equilibrium to find the reactions at the ends of the member. To find the axial and shear forces in member  $AB$  we need to resolve the components of both the 18.2 kN and 32.25 kN end forces parallel and normal to the member axis.

Horizontal equilibrium of joint  $C$  is:

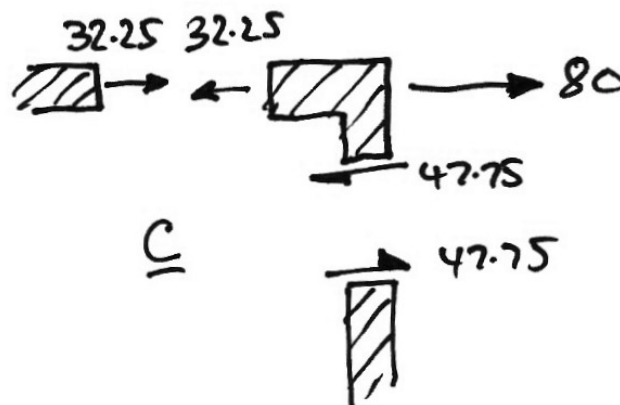

And so the final BMD, deflected shape and reactions are:

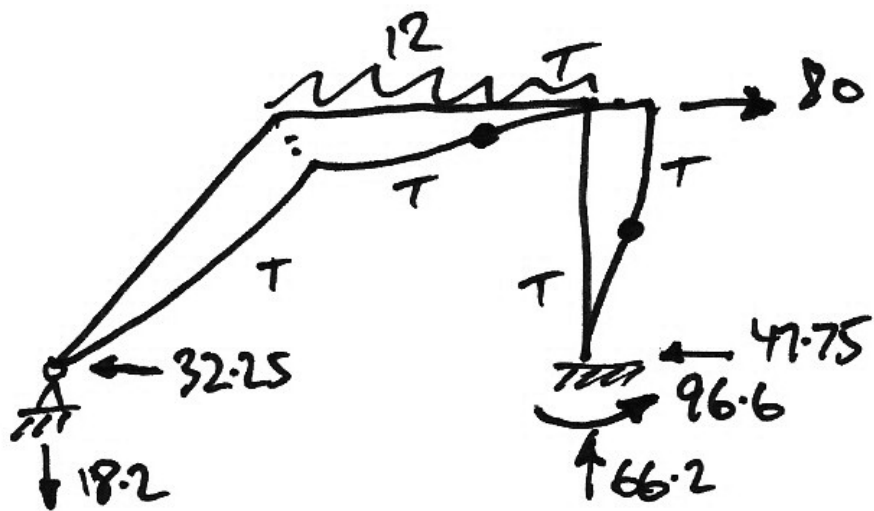
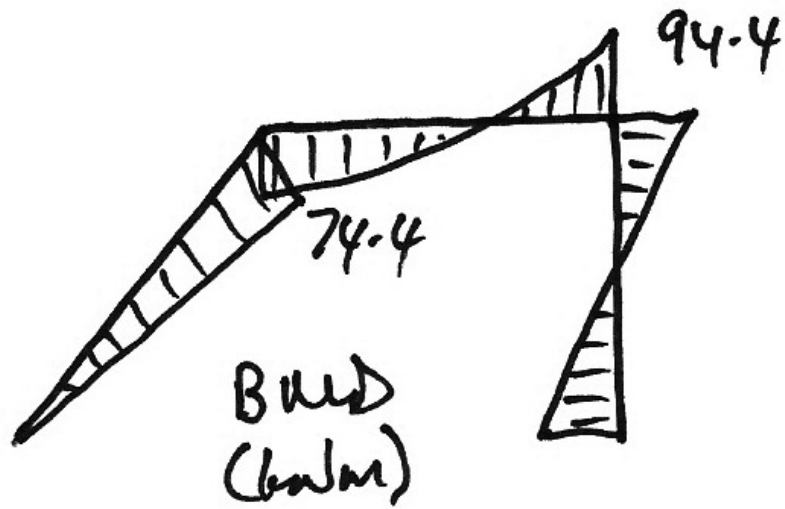

### 5.9 Arbitrary Sway of Oblique Frames Using the ICR

#### Description

For some frames, the method of working with the displacement triangles can be complex and a simpler approach is to consider the Instantaneous Centre of Rotation,  $I_c$ , (ICR) about which the frame rotates. Thus all displacements of the frame can be related to the rotation of the lamina,  $I_cBC$ , about  $I_c$ ,  $\theta^*$ . Then, when working out the ratios,  $\theta^*$  will cancel just as  $\Delta^*$  did previously.

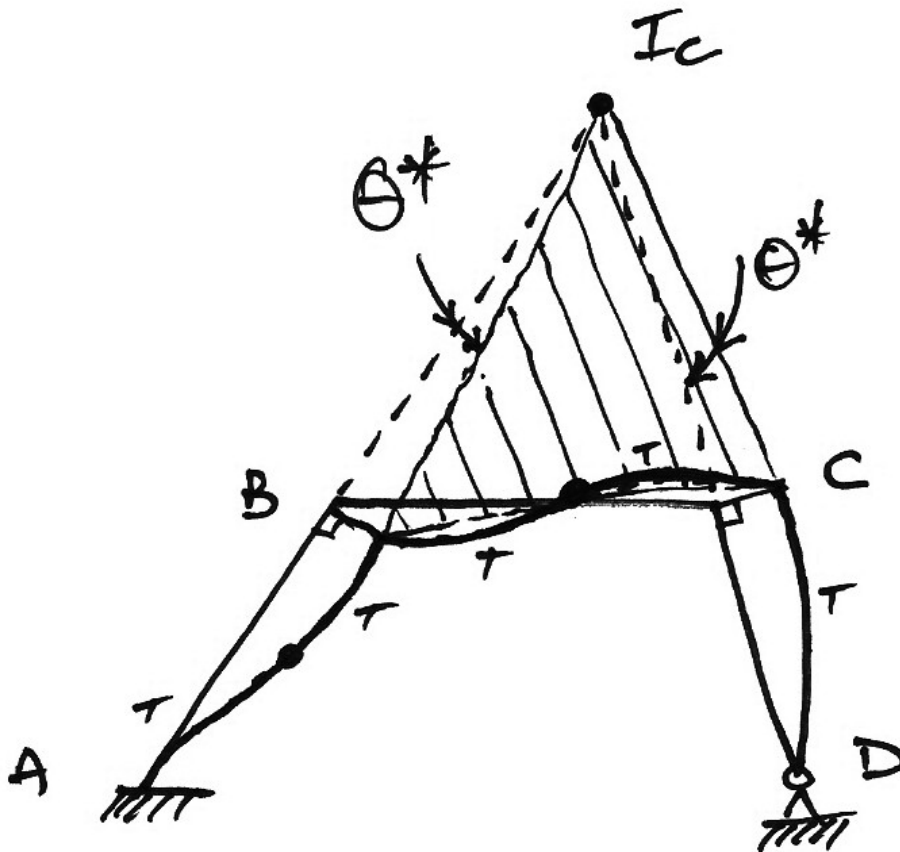

To reiterate: working with  $\theta^*$  may offer a simpler solution than working with  $\Delta^*$ . Both are correct, they are merely alternatives.

**Numerical Example I**

Taking the same frame as we dealt with previously, we will use the centre of rotation approach:

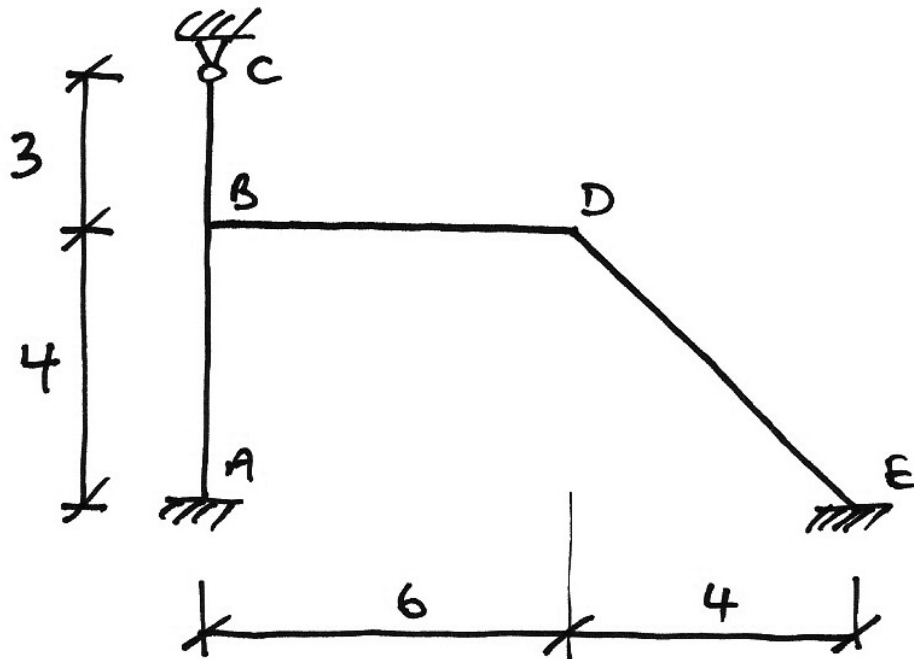

The first step is to identify the  $I_c$  by producing the lines of the members until they intercept as per the following diagram.

Note that in the diagram, the distances to the  $I_c$  are worked out by similar triangles. The  $4-4-4\sqrt{2}$  triangle of member  $DE$  is similar to the  $AI_cE$  triangle and so the lengths  $|I_cC|$  and  $|I_cD|$  are determined.

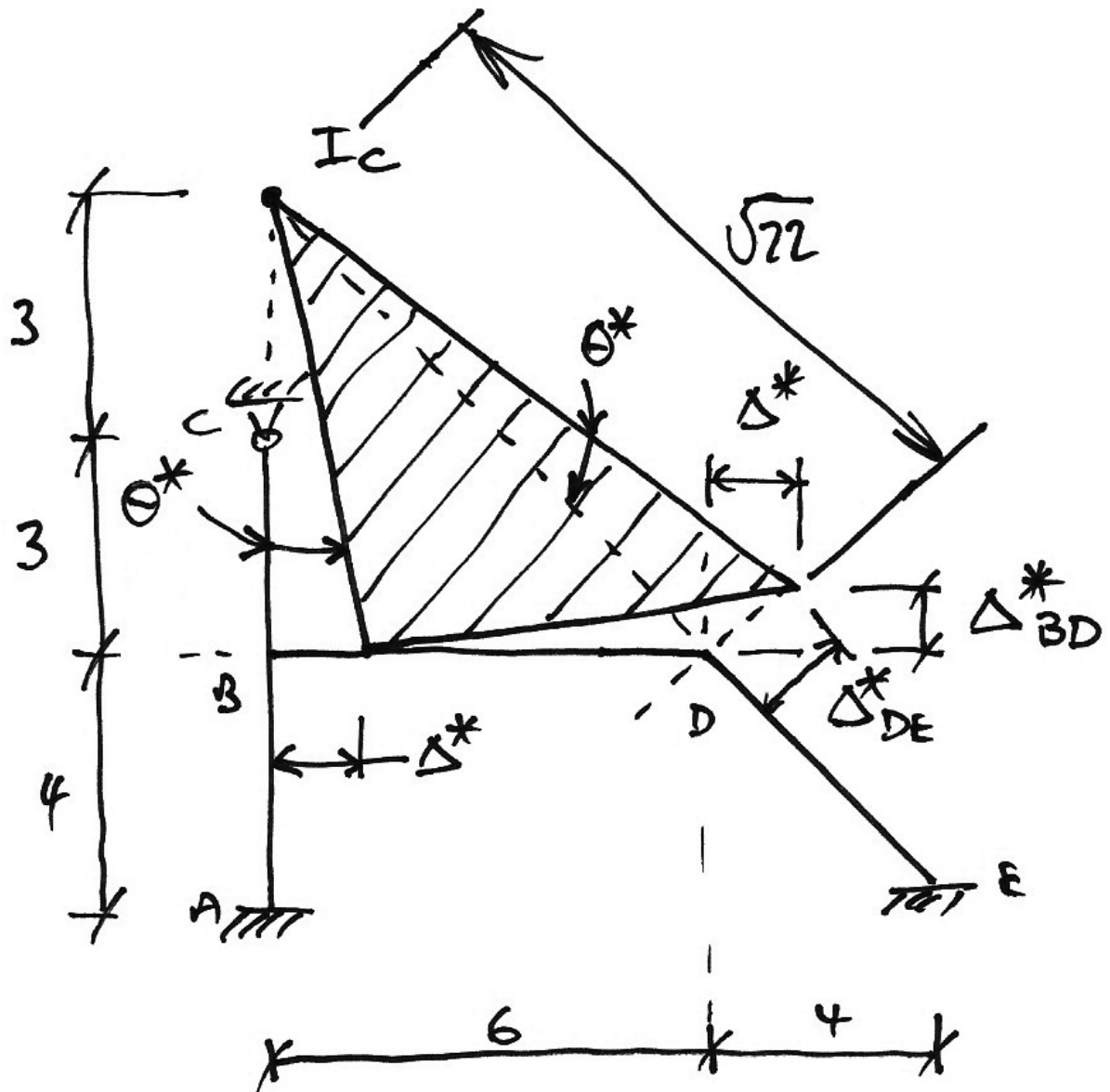

From the length  $|I_c B|$ , we have, using the  $S = R\theta$  for small angles:

$$\Delta^* = 6\theta^*$$

Similarly, length  $|I_c D|$  gives:

$$\Delta_{DE}^* = 6\sqrt{2}\theta^*$$



The length  $|BD|$  times the rotation of the lamina,  $\theta^*$ , gives:

$$\Delta_{BD}^* = 6\theta^*$$

The sway diagram for identifying the FEMs is repeated here:

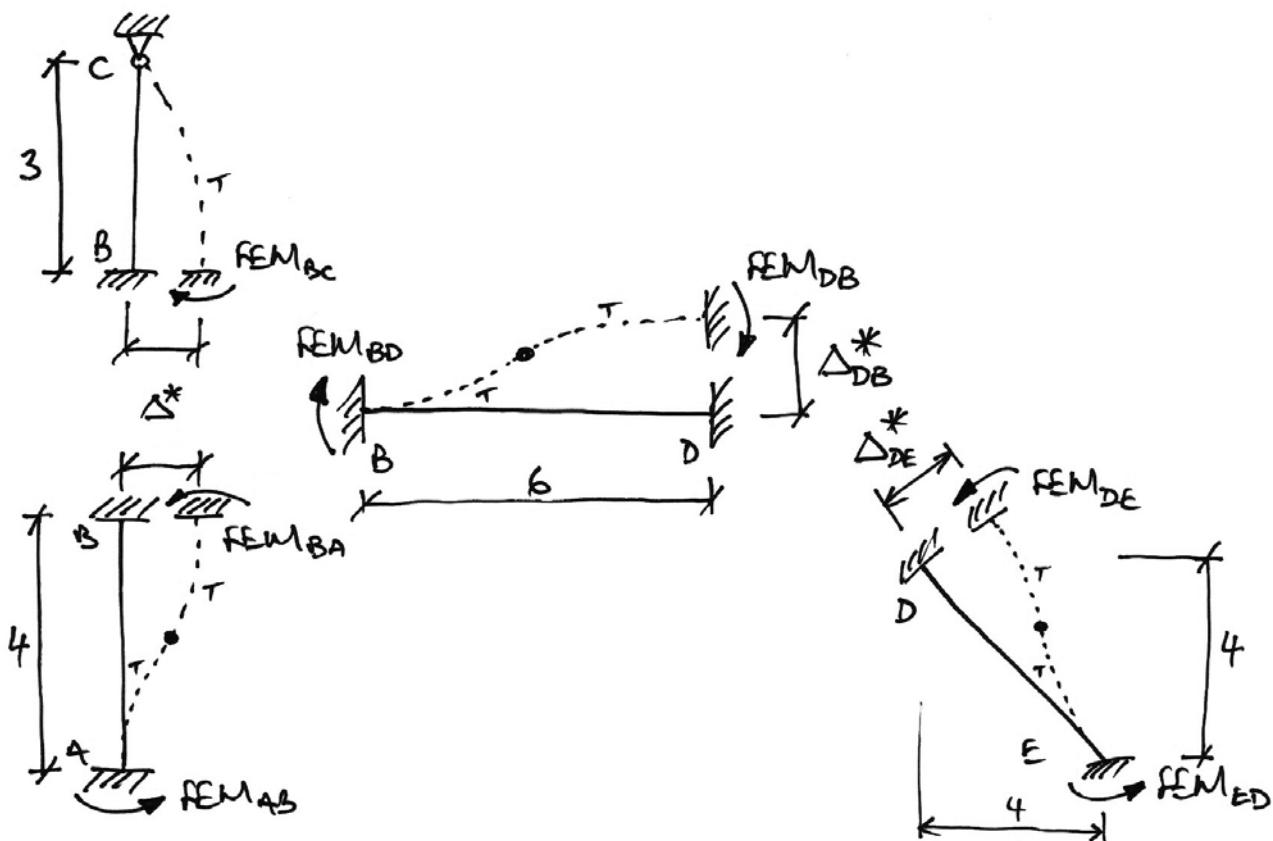

And so the FEMs are in the ratio:

$$\begin{aligned}
 & FEM_{BA} : FEM_{BC} : FEM_{DB} : FEM_{DE} \\
 & \left( \frac{6EI\Delta^*}{L^2} \right)_{AB} : \left( \frac{3EI\Delta^*}{L^2} \right)_{BC} : \left( \frac{6EI\Delta^*}{L^2} \right)_{BD} : \left( \frac{6EI\Delta^*}{L^2} \right)_{DE} \\
 & \frac{6\Delta^*}{4^2} : \frac{3\Delta^*}{3^2} : \frac{6\Delta_{DB}^*}{6^2} : \frac{6\Delta_{DE}^*}{(4\sqrt{2})^2}
 \end{aligned}$$

Now substitute in the relationships between  $\theta^*$  and the various sways:

$$\begin{array}{ccccccc} \frac{6(6\theta^*)}{4^2} & : & \frac{3(6\theta^*)}{3^2} & : & \frac{6(6\theta^*)}{6^2} & : & \frac{6(6\sqrt{2}\theta^*)}{(4\sqrt{2})^2} \\ \frac{36}{16} & : & \frac{18}{9} & : & \frac{36}{36} & : & \frac{36\sqrt{2}}{32} \\ \frac{9}{4} & : & 2 & : & 1 & : & \frac{9\sqrt{2}}{8} \\ 18 & : & 16 & : & 8 & : & 9\sqrt{2} \end{array}$$

And multiplying by 6, say, so that rounding won't affect results gives:

$$\begin{array}{ccccccc} FEM_{BA} & : & FEM_{BC} & : & FEM_{DB} & : & FEM_{DE} \\ 108 \text{ kNm} & : & 96 \text{ kNm} & : & 48 \text{ kNm} & : & 76.4 \text{ kNm} \end{array}$$

And this is the same set of arbitrary moments we calculated earlier when using displacement triangles instead of this  $I_c$  method.

This should help emphasize to you that choosing displacement triangles or the  $I_c$  method is simply a matter of preference and ease of calculation.

### Numerical Example II

In this example, we just work out the arbitrary moments for the frame of Example 11.

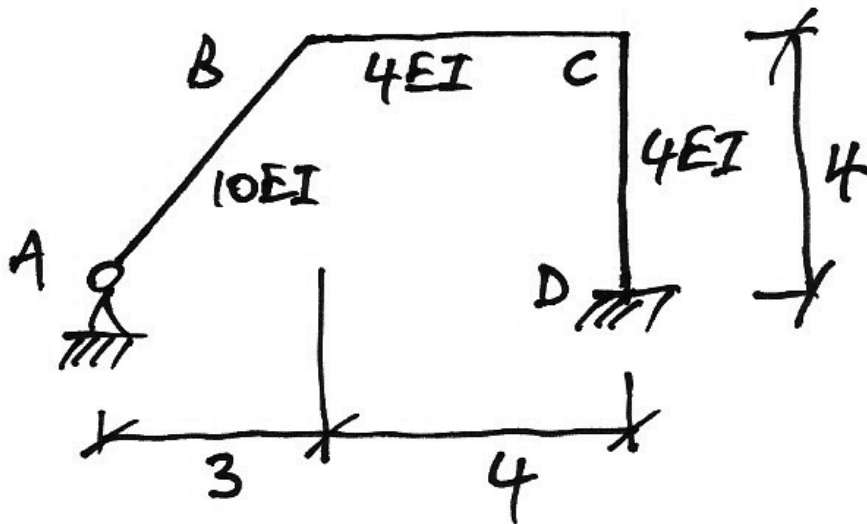

We identify the  $I_c$  by producing the lines of the members until they intercept as per the following diagram.

The distances to the  $I_c$  are worked out by similar triangles. The 3-4-5 triangle of member  $AB$  is similar to the  $BI_cC$  triangle and so the length of member  $BC$  of 4 m forms the '3' side of the triangle and so the lengths  $|I_cB|$  and  $|I_cC|$  are determined since they are the 5 and 4 sides respectively.

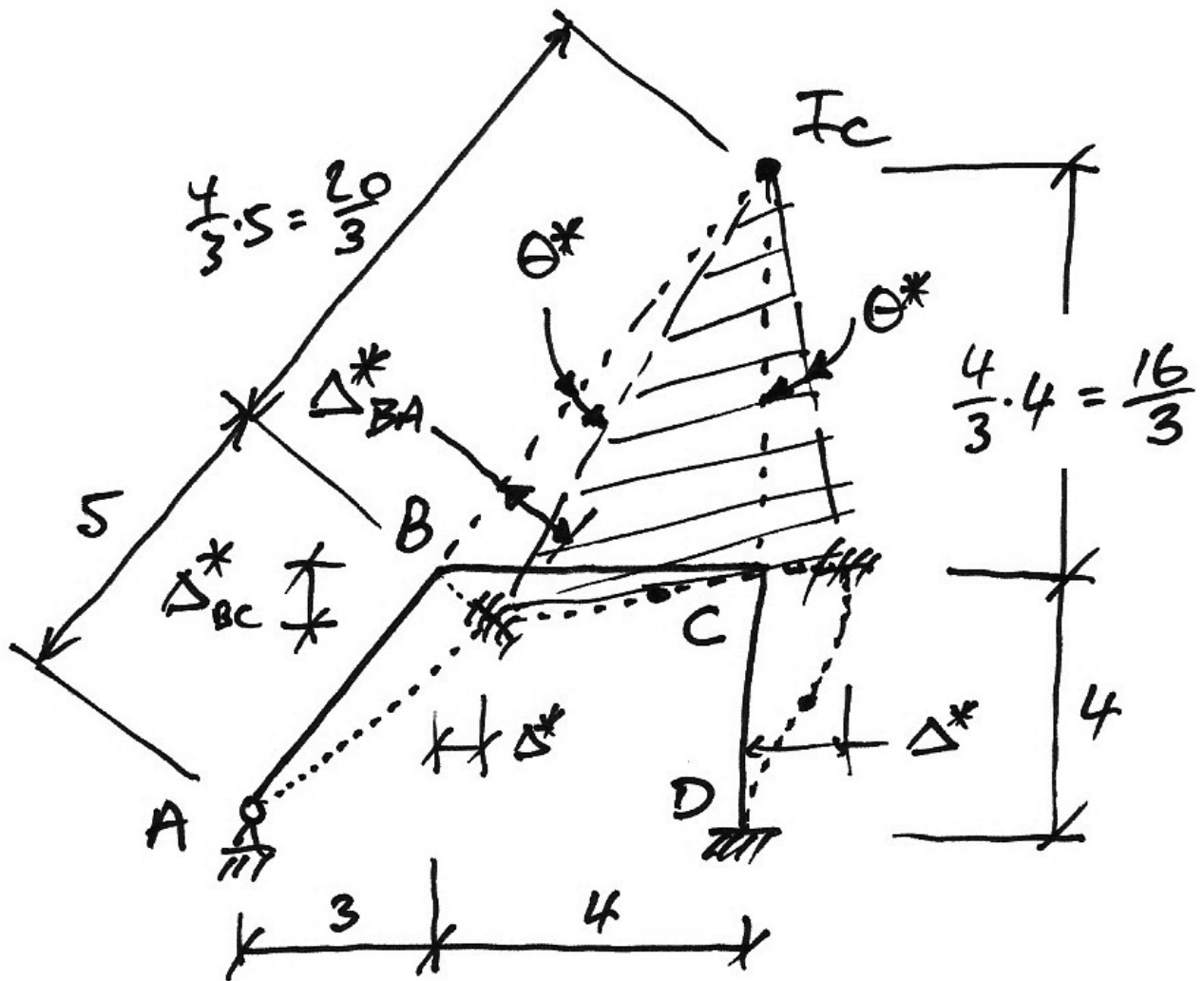

Using the  $S = R\theta$  relations we have:

- From the length  $|I_c C|$ , we have:  $\Delta^* = \frac{16}{3}\theta^*$ ;
- Similarly, length  $|I_c B|$  gives:  $\Delta_{BA}^* = \frac{20}{3}\theta^*$ ;
- The length  $|BC|$  times  $\theta^*$  gives:  $\Delta_{BC}^* = 4\theta^*$ .

The FEMs are the following:

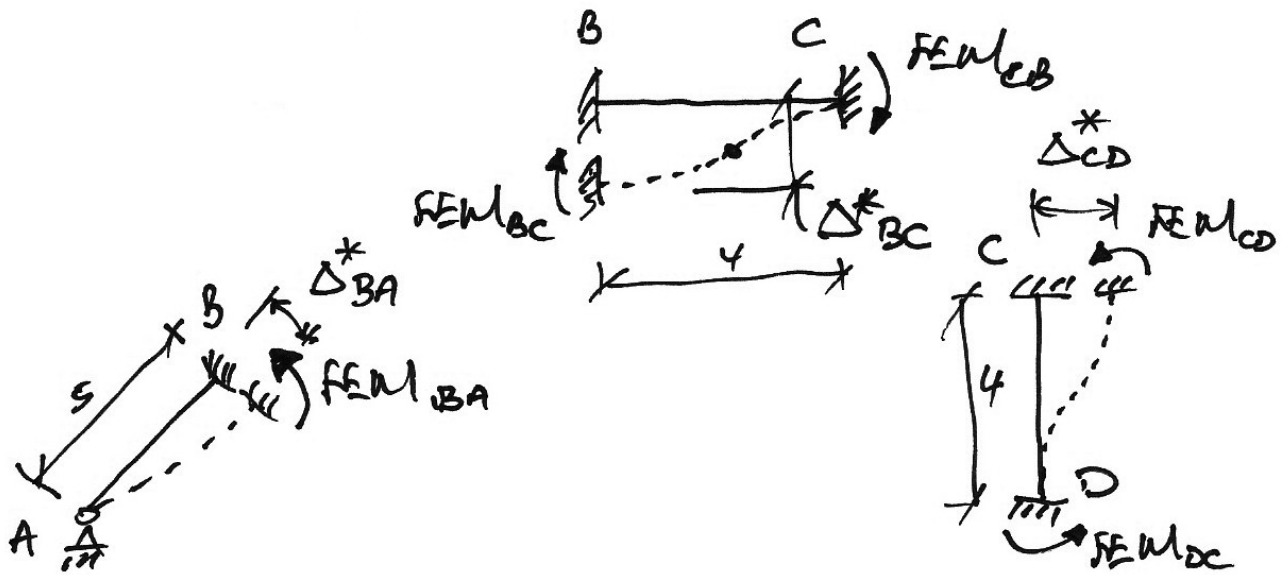

And so we have:

$$\begin{array}{lcl}
 FEM_{BA} & : & FEM_{BC} & : & FEM_{CD} \\
 \left( +\frac{3EI}{L^2} \Delta^* \right)_{AB} & : & \left( -\frac{6EI}{L^2} \Delta^* \right)_{BC} & : & \left( +\frac{6EI}{L^2} \Delta^* \right)_{CD} \\
 +\frac{3(10EI)}{5^2} \Delta^*_{BA} & : & -\frac{6(4EI)}{4^2} \Delta^*_{BC} & : & +\frac{6(4EI)}{4^2} \Delta^* \\
 +\frac{30}{25} \cdot \frac{20}{3} \theta^* & : & -\frac{24}{16} \cdot 4\theta^* & : & +\frac{24}{16} \cdot \frac{16}{3} \theta^* \\
 +240 \text{ kNm} & : & -180 \text{ kNm} & : & +240 \text{ kNm}
 \end{array}$$

Which is as we found previously. The arbitrary sways are thus:

$$\begin{array}{l}
 \frac{6(4EI)}{4^2} \Delta^* = 240 \Rightarrow \Delta^* = \frac{160}{EI} \\
 \Delta^* = \frac{16}{3} \theta^* = \frac{160}{EI} \Rightarrow \theta^* = \frac{30}{EI}
 \end{array}$$

**Class Problems**

Using the  $I_c$  method, verify the arbitrary moments found previously for the following frames:

1.	
2.	
3.	

5.10 Example 13: Oblique Sway Frame II

Problem – Summer 2007

Draw the bending moment diagrams for the following frames:

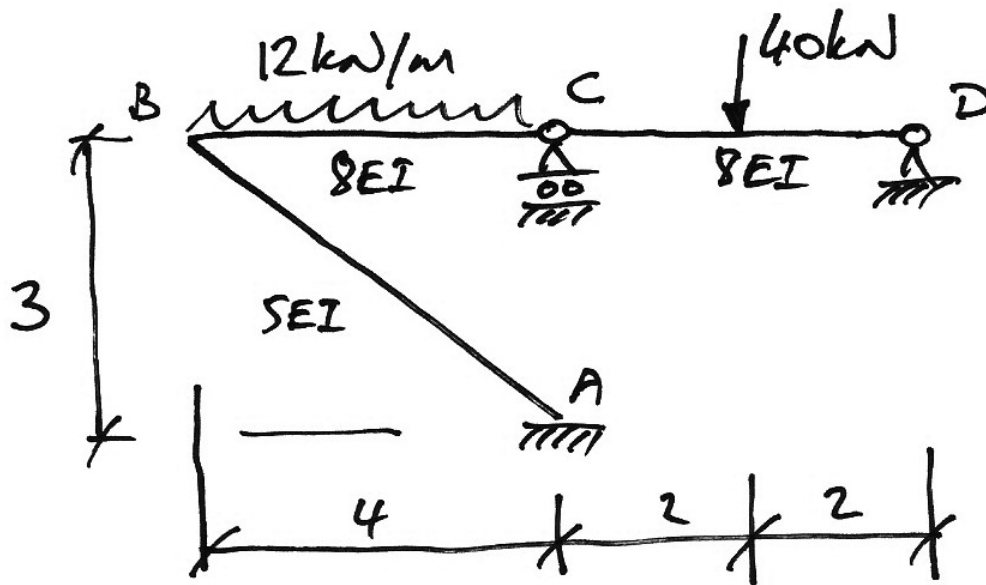

Structure 1

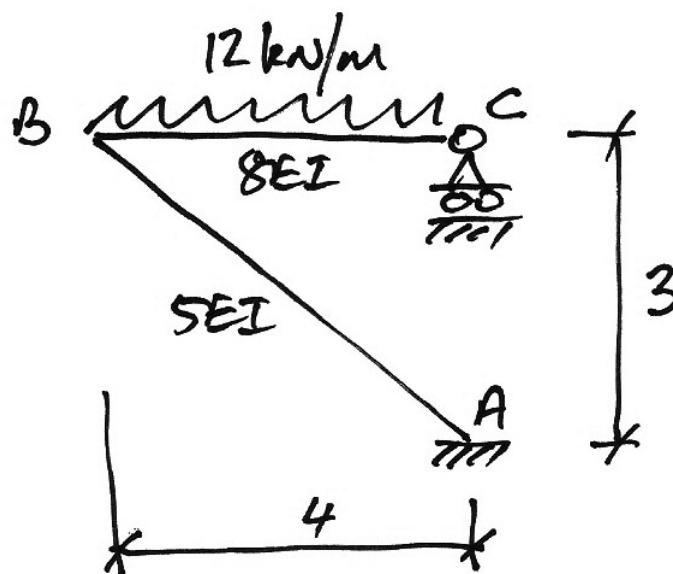

Structure 2

**Solution**

**Structure 1**

This is a non-sway structure, and so a two-stage analysis is not required. Also, importantly, since there is no moment transferred through the pin at  $C$  the 40 kN point load does not cause any moments to be transferred around the frame. Therefore member  $CD$  does not enter the moment distribution analysis: essentially the beam  $CD$  is a separate structure, except that the horizontal restraint at  $D$  prevents sway of  $ABC$ .

1. Stiffnesses:

- $AB$ :  $k_{AB} = \left(\frac{EI}{L}\right)_{AB} = \frac{5EI}{5} = EI$
- $BC$ :  $k'_{BC} = \frac{3}{4} \left(\frac{EI}{L}\right)_{BC} = \frac{3}{4} \cdot \frac{8EI}{4} = \frac{6EI}{4}$
- $CD$ :  $k_{BD} = 0$  - there is no moment transferred through the pin at  $C$ .

2. Distribution Factors:

- Joint  $B$ :

$$\sum k = EI + \frac{6EI}{4} = \frac{10EI}{4} \Rightarrow DF_{BA} = \frac{EI}{\frac{10EI}{4}} = 0.4 \quad DF_{BC} = \frac{\frac{6EI}{4}}{\frac{10EI}{4}} = 0.6$$

3. Fixed-End Moments:

- Span  $BC$ :

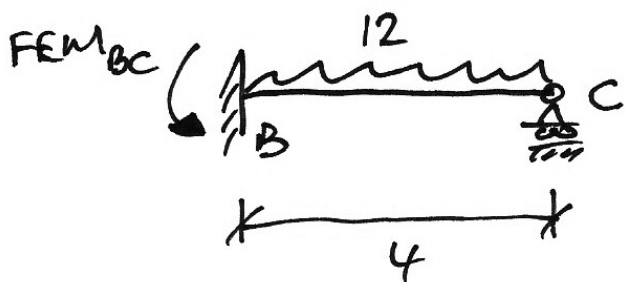

$$FEM_{BC} = +\frac{wL^2}{8} = +\frac{12 \cdot 4^2}{8} = +24 \text{ kNm}$$



4. Moment Distribution Table:

Joint	A	B		C
Member	AB	BA	BC	CB
DF		0.4	0.6	
FEM			+24	
Dist.		-9.6	-14.4	
C.O.	-4.8			
Final	-4.8	-9.6	+9.6	0

5. End Shears and Forces:

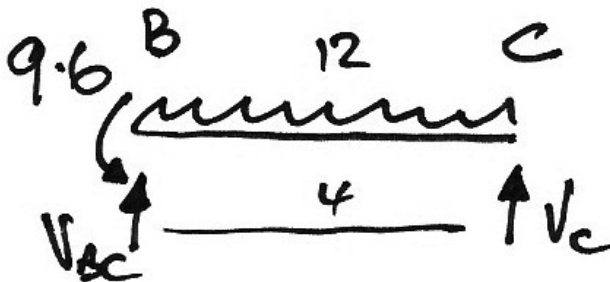

$$\sum M \text{ about } B = 0$$

$$\therefore -9.6 + 12 \cdot \frac{4^2}{2} - 4V_c = 0$$

$$\therefore V_c = +21.6 \text{ kN } \uparrow$$

$$\sum F_y = 0$$

$$\therefore 12 \cdot 4 - 21.6 - V_{BC} = 0$$

$$\therefore V_{BC} = 26.4 \text{ kN } \uparrow$$

Zero shear is at  $21.6/12 = 1.8$  m to the left of C. Hence:

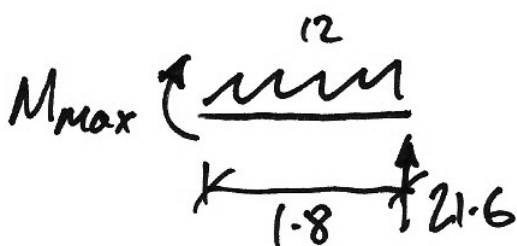

$$\sum M \text{ about } M_{\max} = 0$$

$$\therefore M_{\max} + 12 \cdot \frac{1.8^2}{2} - 21.6 \cdot 1.8 = 0$$

$$\therefore M_{\max} = +19.44 \text{ kNm}$$

The axial force transmitted to member  $CD$  from the frame  $ABC$  is:

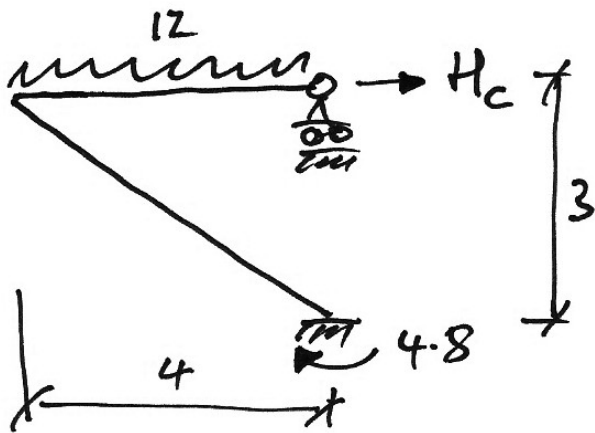

$$\sum M \text{ about } A = 0$$

$$\therefore 4.8 - 12 \cdot \frac{4^2}{2} + 3H_c = 0$$

$$\therefore H_c = +30.4 \text{ kN} \rightarrow$$

Thus,  $H_d = 30.4 \text{ kN} \rightarrow$

And since the span  $CD$  is a simply supported beam, the BMD is thus:

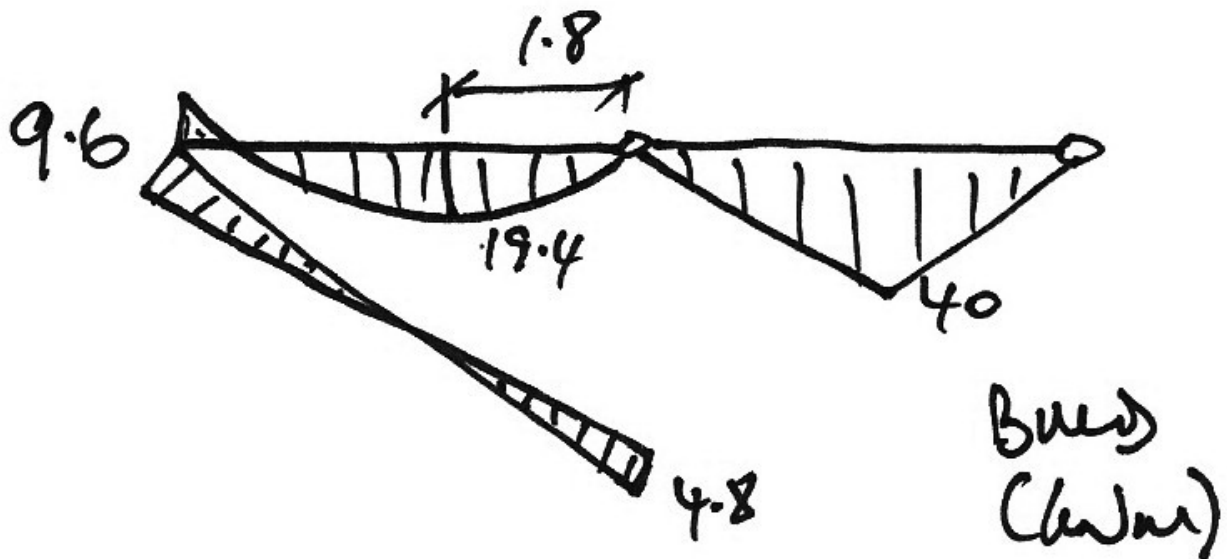

**Structure 2**

This is a sway structure and so a two-stage analysis is required:

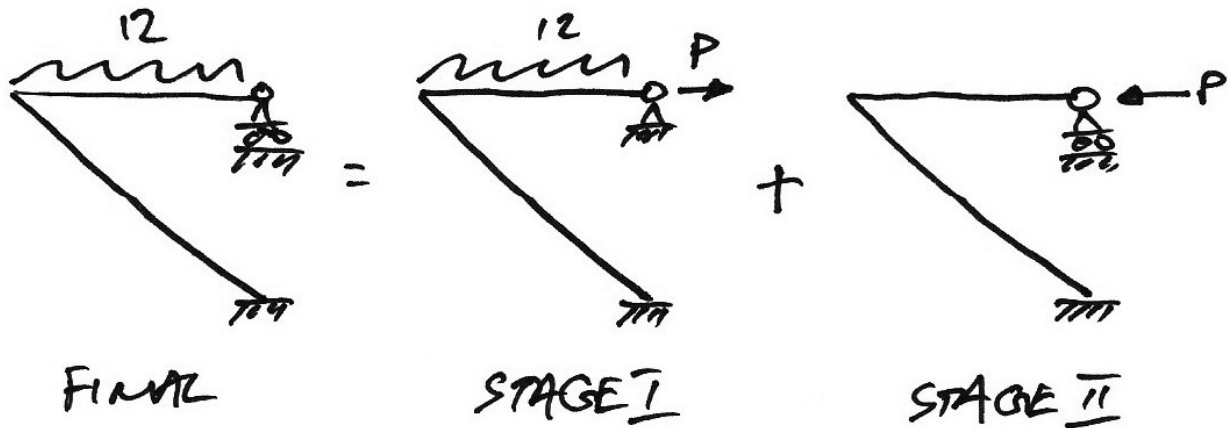

Looking at this superposition, we can recognize Stage I as Structure I, which we have already solved. Hence only Stage II is required. The sway diagram is:

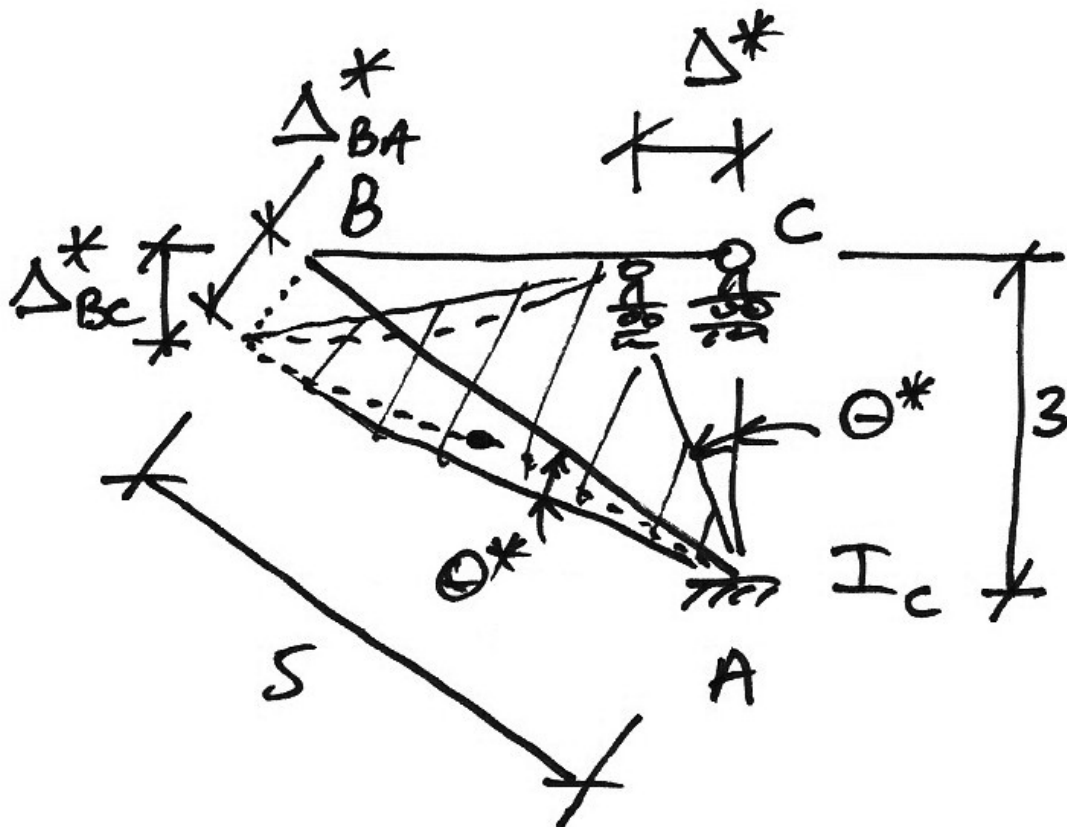

From which, using the  $S = R\theta$  relation, we have:

- From the length  $|I_c C|$ , we have:  $\Delta^* = 3\theta^*$ ;
- Similarly, length  $|I_c B|$  gives:  $\Delta_{BA}^* = 5\theta^*$ ;
- The length  $|BC|$  gives:  $\Delta_{BC}^* = 4\theta^*$ .

The FEMs are:

$$\begin{aligned}
 FEM_{BA} & : & FEM_{BC} \\
 \left( -\frac{6EI}{L^2} \Delta^* \right)_{BA} & : & \left( -\frac{3EI}{L^2} \Delta^* \right)_{BC} \\
 -\frac{6(5EI)}{5^2} \Delta_{BA}^* & : & -\frac{3(8EI)}{4^2} \Delta_{BC}^* \\
 -\frac{30}{25} \cdot 5\theta^* & : & -\frac{24}{16} \cdot 4\theta^* \\
 -20 \text{ kNm} & : & -20 \text{ kNm}
 \end{aligned}$$

The associated sways are:

$$\begin{aligned}
 \frac{6(5EI)}{5^2} \cdot 5\theta^* = 20 & \Rightarrow \theta^* = \frac{3.33}{EI} \\
 \Delta^* = 3\theta^* = 3 \cdot \frac{3.33}{EI} & \Rightarrow \Delta^* = \frac{10}{EI}
 \end{aligned}$$

Joint	A	B		C
Member	AB	BA	BC	CB
DF		0.4	0.6	
FEM	-20	-20	-20	
Dist.		+16	+24	
C.O.	+8			
Final	-12	-4	+4	0

The sway force is found from:

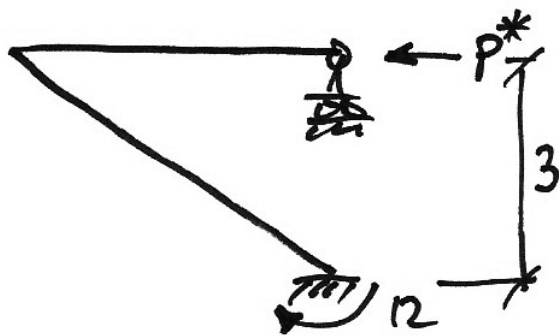

$$\begin{aligned} \sum M \text{ about } A &= 0 \\ \therefore 12 - 3P^* &= 0 \\ \therefore P^* &= +4 \text{ kN } \leftarrow \end{aligned}$$

$$\alpha = \frac{P}{P^*} = \frac{30.4}{4} = 7.6$$

Joint Member	A	B		C
	AB	BA	BC	CB
Stage II* ( $M_{II}^*$ )	-12	-4	+4	0
Stage II ( $M_{II}$ )	-91.2	-30.4	+30.4	0
Stage I ( $M_I$ )	-4.8	-9.6	+9.6	0
Final ( $M$ )	-96	-40	+40	0

$$\Delta = \alpha \Delta^* = 7.6 \cdot \frac{10}{EI} = \frac{76}{EI}$$

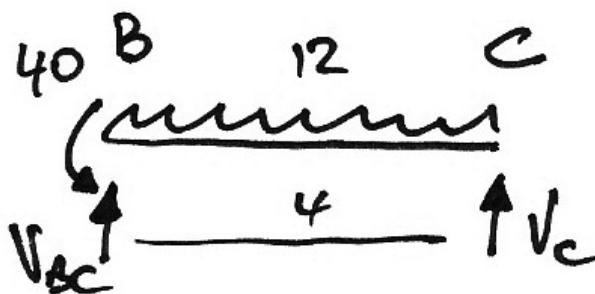

$$\begin{aligned} \sum M \text{ about } B &= 0 \\ \therefore -40 + 12 \cdot \frac{4^2}{2} - 4V_C &= 0 \\ \therefore V_C &= +14 \text{ kN } \uparrow \end{aligned}$$

$$\begin{aligned} \sum F_y &= 0 \\ \therefore 12 \cdot 4 - 14 - V_{BC} &= 0 \\ \therefore V_{BC} &= 34 \text{ kN } \uparrow \end{aligned}$$

Zero shear occurs at  $14/12 = 1.17$  m to the left of C. Hence:

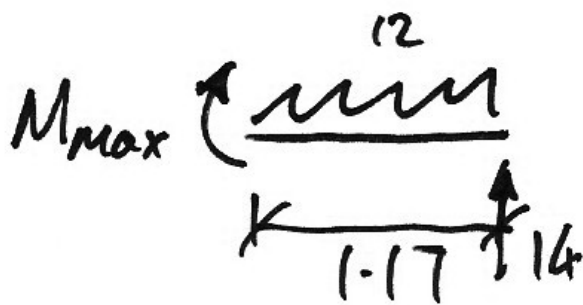

$$\sum M \text{ about } M_{\max} = 0$$

$$\therefore M_{\max} + 12 \cdot \frac{1.17^2}{2} - 21.6 \cdot 1.17 = 0$$

$$\therefore M_{\max} = +8.2 \text{ kNm}$$

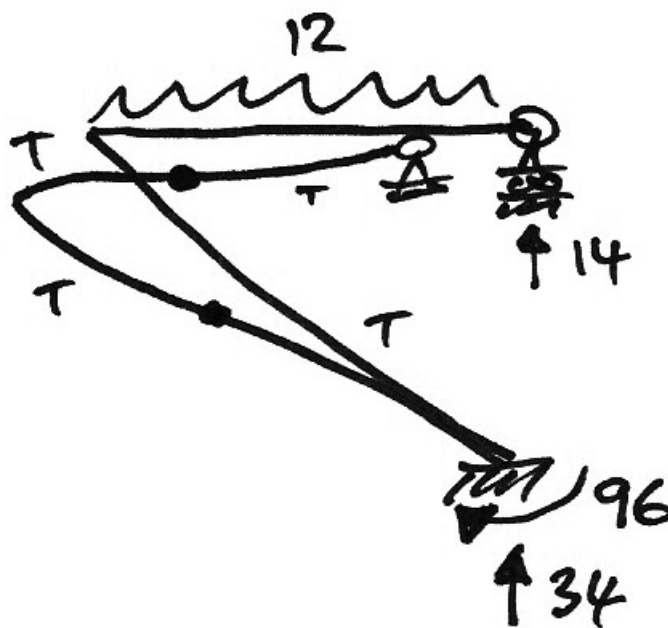
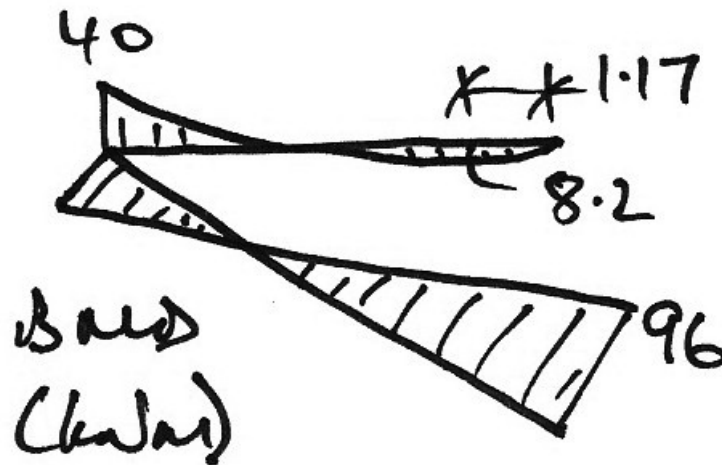

5.11 Problems II

<p>9.</p>		<p> <math>V_A = 91.8 \text{ kN} \uparrow</math>  <math>H_A = 9.7 \text{ kN} \rightarrow</math>  <math>M_A = -9.3 \text{ kNm}</math>  <math>V_C = 0 \text{ kN}</math>  <math>H_C = 16.5 \text{ kN} \leftarrow</math>  <math>V_E = 88.2 \text{ kN} \uparrow</math>  <math>H_E = 93.1 \text{ kN} \leftarrow</math>  <math>M_E = +39.5 \text{ kNm}</math>   <math>M_{BA} = 29.4 \text{ kNm}</math>  <math>M_{BD} = 79.0 \text{ kNm}</math>  <math>M_{BC} = 49.6 \text{ kNm}</math>  <math>M_D = 68.4 \text{ kNm}</math> </p>
<p>10.</p>		<p> <math>V_A = 167.6 \text{ kN} \uparrow</math>  <math>H_A = 96.0 \text{ kN} \leftarrow</math>  <math>M_A = +435.6 \text{ kNm}</math>  <math>V_C = 80.4 \text{ kN} \uparrow</math>   <math>M_B = 122.6 \text{ kNm}</math> </p>

<p>11.</p>		<p> <math>V_A = 56.1 \text{ kN} \downarrow</math>  <math>H_A = 71.8 \text{ kN} \leftarrow</math>  <math>V_D = 56.1 \text{ kN} \uparrow</math>  <math>H_D = 28.2 \text{ kN} \leftarrow</math>  <math>M_D = +94.9 \text{ kNm}</math>   <math>M_B = 118.9 \text{ kNm}</math>  <math>M_{CD} = 17.9 \text{ kNm}</math>  <math>M_{CB} = 217.9 \text{ kNm}</math> </p>
<p>12.</p>		<p> <math>V_A = 33.5 \text{ kN} \uparrow</math>  <math>H_A = 6.0 \text{ kN} \leftarrow</math>  <math>M_A = +82.1 \text{ kNm}</math>  <math>V_D = 86.5 \text{ kN} \uparrow</math>  <math>H_C = 6 \text{ kN} \rightarrow</math>  <math>M_D = 119.1 \text{ kNm}</math>   <math>M_B = 42.5 \text{ kNm}</math>  <math>M_C = 116.3 \text{ kNm}</math> </p>



## 6. Appendix

### 6.1 Past Exam Papers

#### Sample Paper 2007/8

2. Using *Moment Distribution*:

- (i) Determine the bending moment moments for the frame in Fig. Q2;
- (ii) Draw the bending moment diagram for the frame, showing all important values;
- (iii) Draw the deflected shape diagram for the frame.

(40 marks)

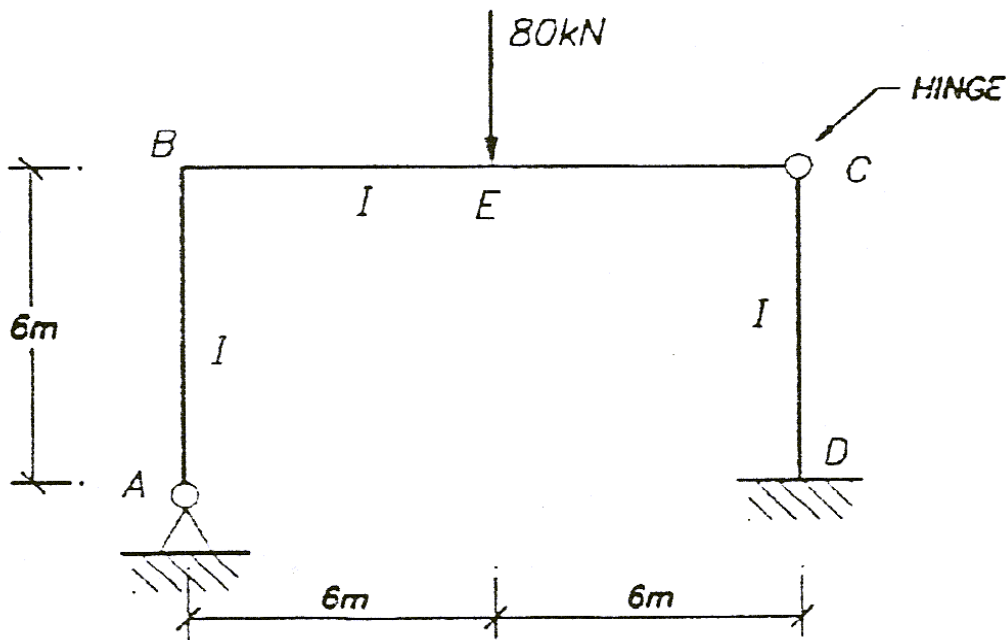

FIG Q2

Semester 1 2007/8

QUESTION 2

For the frame shown in Fig. Q2, using *Moment Distribution*:

- (i) Draw the bending moment diagram for the frame, showing all important values;
- (ii) Draw the deflected shape diagram for the frame.

(40 marks)

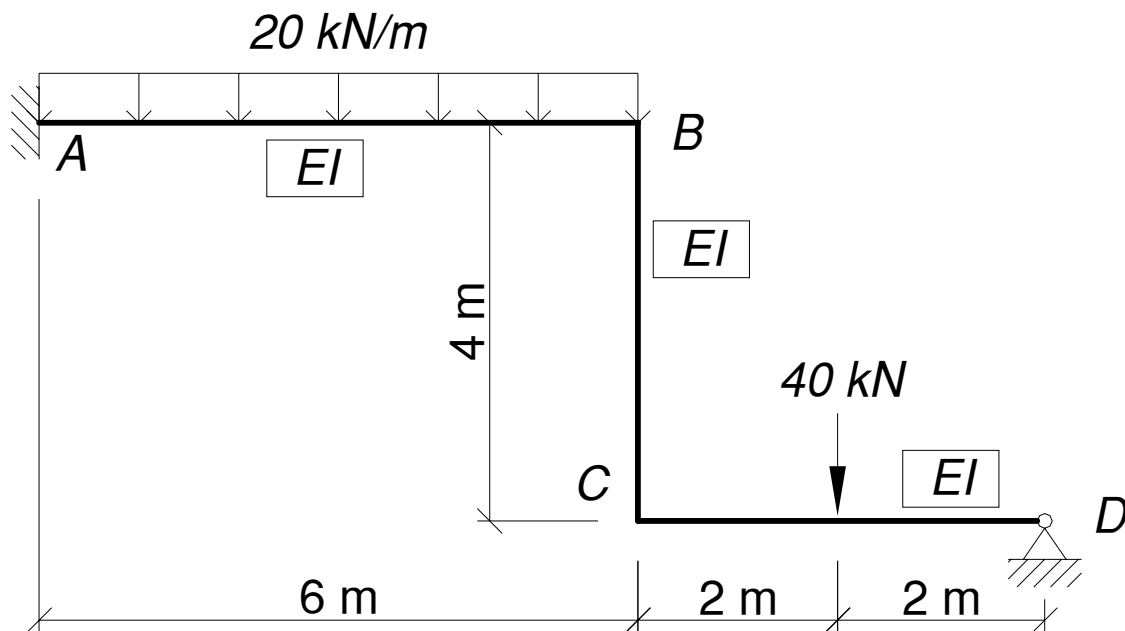

**FIG. Q2**

---

Ans.  $M_A = 249.2$  kNm;  $M_B = 73.8$  kNm;  $M_C = 104$  kNm

**Supplemental Semester 1 2007/8**

**QUESTION 2**

For the frame shown in Fig. Q2, using *Moment Distribution*:

- (iii) Draw the bending moment diagram for the frame, showing all important values;
- (iv) Draw the deflected shape diagram for the frame.

(40 marks)

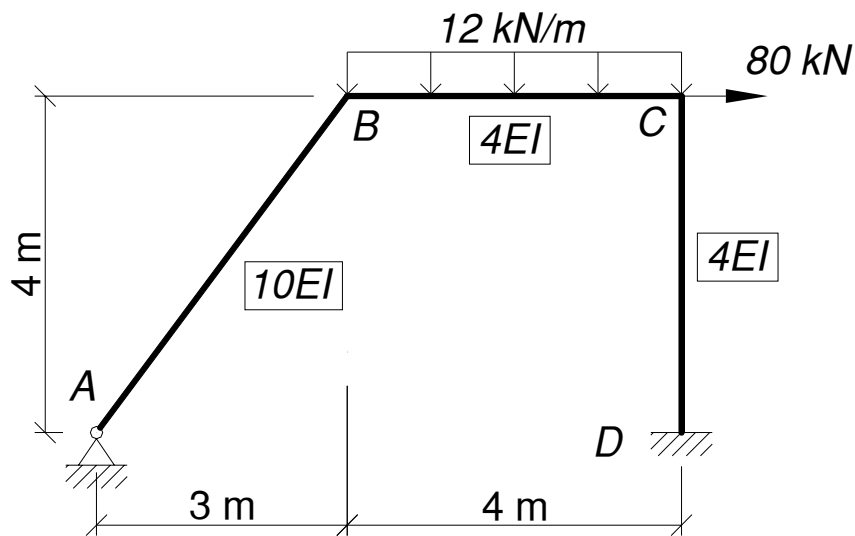

**FIG. Q2**

Ans.  $M_B = 74.4 \text{ kNm}$ ;  $M_C = 94.4 \text{ kNm}$ ;  $M_D = 96.4 \text{ kNm}$

Semester 1 2008/9

QUESTION 2

For the frame shown in Fig. Q2, using *Moment Distribution*:

- (v) Draw the bending moment diagram for the frame, showing all important values;
- (vi) Draw the deflected shape diagram for the frame.

(40 marks)

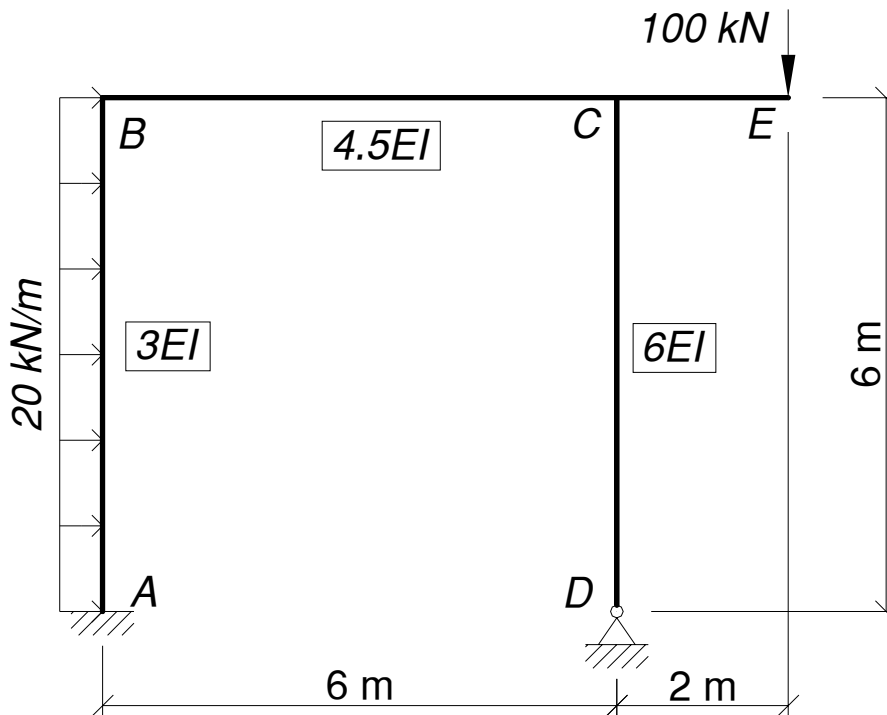
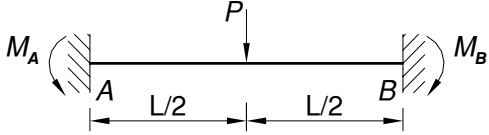
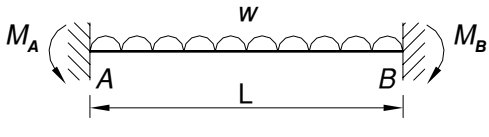
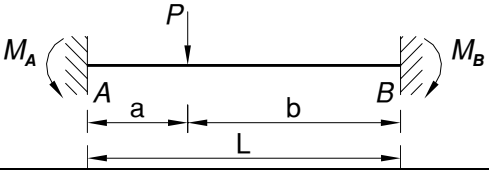
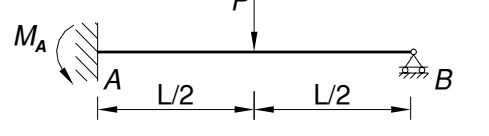
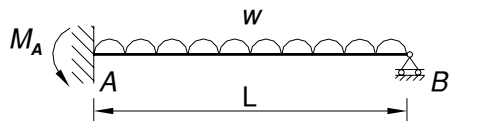
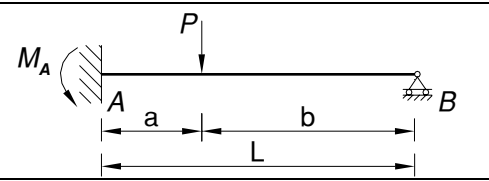
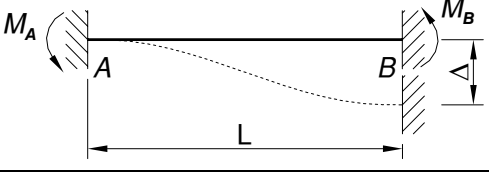
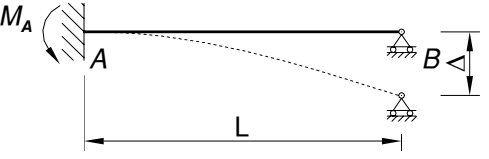

**FIG. Q2**

Ans.  $M_A = 240 \text{ kNm}$ ;  $M_B = 111 \text{ kNm}$ ;  $M_{CB} = 196 \text{ kNm}$ ;  $M_{CD} = 4 \text{ kNm}$

**6.2 Fixed End Moments**

For both loads and displacements:

$M_A$	Configuration	$M_B$
$+\frac{PL}{8}$		$-\frac{PL}{8}$
$+\frac{wL^2}{12}$		$-\frac{wL^2}{12}$
$+\frac{Pab^2}{L^2}$		$-\frac{Pa^2b}{L^2}$
$+\frac{3PL}{16}$		-
$+\frac{wL^2}{8}$		-
$+\frac{Pab(2L-a)}{2L^2}$		-
$+\frac{6EI\Delta}{L^2}$		$+\frac{6EI\Delta}{L^2}$
$+\frac{3EI\Delta}{L^2}$		-